

# INTRODUCTION TO PM **HIP** TECHNOLOGY

A guide for Designers and Engineers

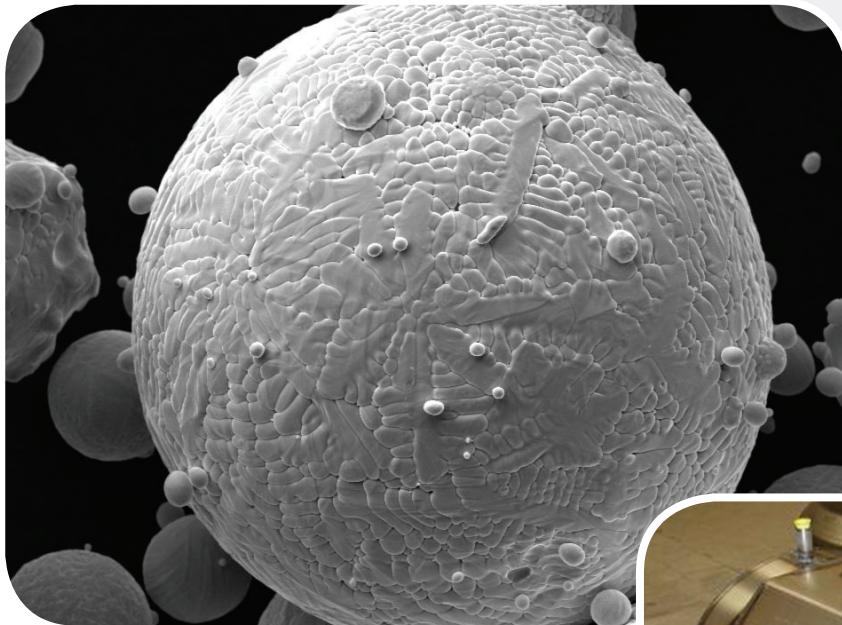

# CONTENTS

## Hot Isostatic Pressing (HIP)

HIP has established itself in the past decade as a competitive and proven manufacturing process for the production of complex and highly specified components made from a wide range of metals and/or ceramics.

These components are currently being used in a number of industry sectors that have highly demanding environments for example: aerospace, offshore, energy and medical. In this guide, which is aimed at users or potential users of HIPped parts, we will focus on the use of metal powders as the raw material used in the process and how they can deliver your requirements.

	<b>Page</b>
<b>1. INTRODUCTION</b>	<b>3</b>
<b>2. BENEFITS OF HIP TECHNOLOGY AND ITS MAIN USES</b>	<b>4</b>
2.1 - The Main Benefits of the PM HIP technology	4
2.2 - PM HIP Uses and Applications	5
2.3 - Comparison with Other Manufacturing Technologies	6
<b>3. THE PM HIP PROCESS</b>	<b>7</b>
3.1 - Powder Manufacturing	8 - 9
3.2 - Container Manufacturing	10
3.3 - Container Filling and Outgassing	10
3.4 - The Hot Isostatic Pressing Process	11 - 12
3.5 - Container Removal	13
3.6 - Post Processing Operations	13
3.7 - Quality and Testing	13
<b>4. MICROSTRUCTURE OF PM HIP PARTS</b>	<b>14</b>
4.1 - Stainless Steels	14
4.2 - High Speed Tool Steels	15
<b>5. DESIGN GUIDELINES</b>	<b>16</b>
5.1 - Introduction	16
5.2 - Computer Modelling	16 - 17
5.3 - Container Materials	18
5.4 - Container Shrinkage	19
5.5 - Positioning of Container Welded Seams	19 - 20
5.6 - Container Deformation	20 - 21
5.7 - Tolerances of PM HIP parts	21
5.8 - Summary	21
<b>6. CASE STUDIES</b>	<b>22 - 27</b>

## ACKNOWLEDGEMENTS

EPMA would like to thank the following companies for sponsoring this brochure:



EPMA would also like to thank the following people and companies for supplying images that have been used throughout this brochure:

AREVA NP Atomising Systems Ltd  
Atomising Systems Ltd  
Aubert et Duval  
Avure Technologies AB  
Bodycote  
Carpenter Powder Products AB  
EPMA Leonardo Project  
Erasteel SA

Kennametal HTM  
Kobelco Metal Powder  
Metal Technology Company Ltd (MTC)  
Metso Minerals Inc  
Olle Grinder  
Rolls Royce  
Sandvik Powdermet AB  
Syntertech

Special Thanks to:

Beat Hofer and Adeline Riou for their editorial input and to the EPHG group members for their support.

Jonathan Wroe, EPMA Executive Director  
Shrewsbury, UK

Copyright © European Powder Metallurgy Association 2011, 2nd Edition, reprint 2013

## INTRODUCTION

### HIP - A high quality cost effective solution.

Hot Isostatic Pressing (HIP) is a process to densify powders or cast and sintered parts in a furnace at high pressure (100-200 MPa) and at temperatures from 900 to 1250°C for example for steels and superalloys. The gas pressure acts uniformly in all directions to provide isotropic properties and 100% densification. It provides many benefits and has become a viable and high performance alternative to conventional processes such as forging, casting and machining in many applications.

Its positioning is very complementary to other powder metallurgy (PM) processes such as Metal Injection Moulding (MIM), pressing and sintering, or the new additive manufacturing technologies. It is even used in combination with these PM processes for part densification and the production of semi finished bars or slabs.

A wide range of component types can be manufactured thanks to HIP. Its capabilities include large and massive near net shape metal components such as oil & gas parts weighing up to 30 tonnes, or net shape impellers up to one metre in diameter. Equally it can be used to make small PM HSS cutting tools, such as taps or drills made from PM HIP semi-finished products, which can weigh less than 100 grams, or even very tiny parts such as dental brackets.

As a result, HIP has developed over the years to become a high-performance, high-quality and cost-effective process for the production of many metal (or ceramic) components.

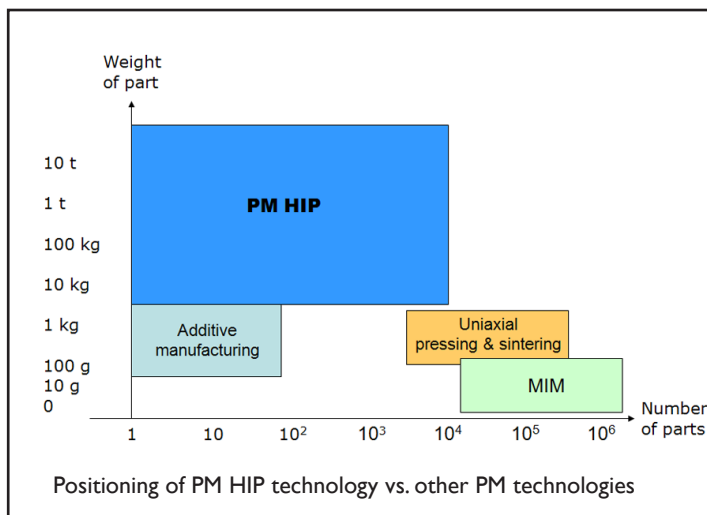

Source: Olle Grinder, Euro PM2009



Net Shape Nickel-base impeller for gas compressor (courtesy of Syntertech)



Large nine tonne stainless Near Net Shape part for oil and gas industry (courtesy of Sandvik Powdermet)

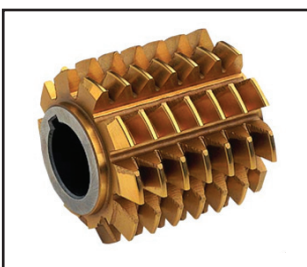

PM HSS gear cutting tool made from PM HIP bar (courtesy of Erasteel)



Compound Injection Extruder (courtesy of Kennametal HTM)

## 2. BENEFITS OF HIP TECHNOLOGY AND ITS MAIN USES

### 2.1 The main benefits of the PM HIP technology

**PM HIP technology offers many benefits in the following key areas:**

Component quality and performance

- Due to the fine and isotropic microstructures produced by HIP
- Reduction of the number of welds on complex parts
- Dense, without segregation

#### Design Flexibility

- Near-Net shapes, Net shapes or Bimetal construction
- Use of composite materials
- Freedom of part sizes and production series
- Freedom of alloys

#### Cost Reduction

- A lean manufacturing route, leading to shorter production leadtimes
- Reduction of machining needs
- Producing single parts where previously several were required
- Less NDT needed and easier NDT

#### Reduced Environmental Impact

- In the case of near-net-shape and net-shape parts due to the excellent material yield compared with conventional metallurgy

*Thanks to the above, PM HIP technology often proves a high quality and cost effective alternative to casting, forging and machining.*

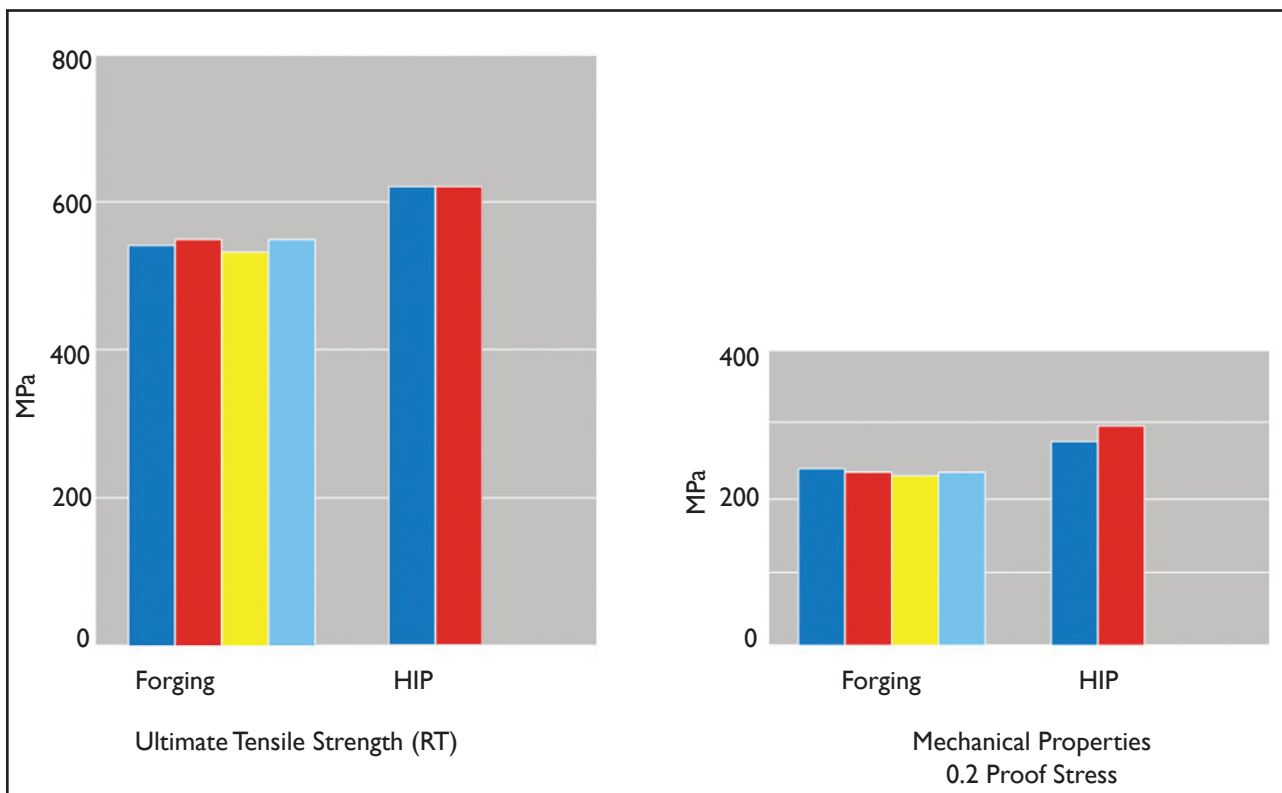

Fig 2.1: An example of comparative properties for various samples for 316L Steel achieved by forging & HIP (courtesy of Rolls Royce)

## 2.2 PM HIP Uses and Applications

This document focuses on HIP technology for the compaction of metal powders in a metal container. In this case, the powder is compacted through pressure while the temperature will ensure diffusion on the contact surface between powder grains, until all hollow spaces are closed so that a 100% density is achieved.

However Hot Isostatic Pressing is also widely used for:

- The densification of cast parts
- The densification of sintered powder parts such as cemented carbides or ceramics
- The densification of MIM parts
- Diffusion bonding between metal parts

Thanks to this wide range of uses HIP is currently employed for the manufacture of parts used in many industry sectors often in business critical and aggressive environments. Some examples of these include:

- Energy
- Process Industry and Tooling
- Transportation and Aerospace
- Nuclear and Scientific
- Oil and Gas

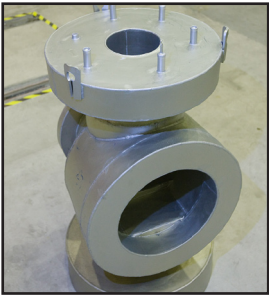

Valve body for offshore subsea stations (courtesy of Metso)



Suction roll shell for paper machines (courtesy of Metso)



Bimetal injector nozzle for diesel engines (courtesy of Sandvik Powdermet)

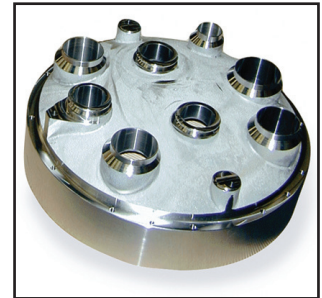

CERN end cover (courtesy of Metso)

In each case HIP has established itself as the preferred process route in key applications.

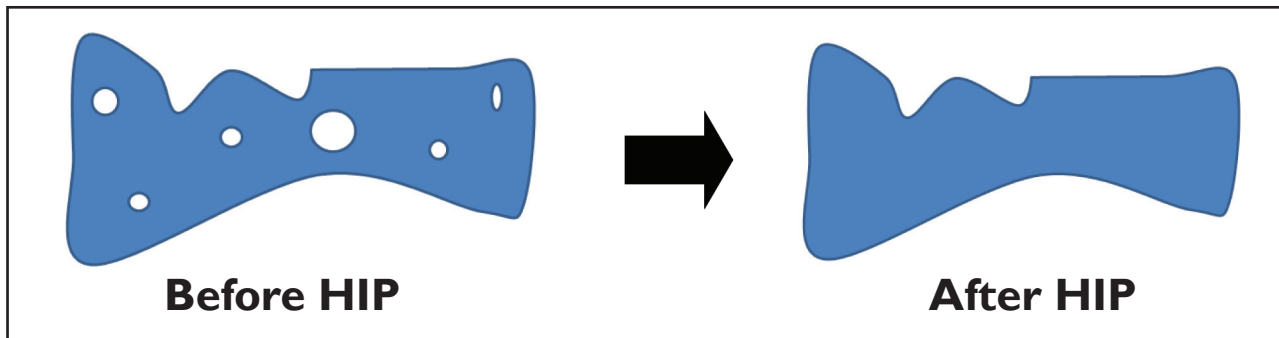

Fig 2.2: Closure of residual internal porosities by Hot Isostatic Pressing, through the combination of pressure and temperature

### 2.3 Comparison with other manufacturing technologies

PM HIP technology is often chosen as an alternative to conventional technologies such as forging and casting. In particular it can offer the following features:

- Improved material properties, provided by the fine and homogenous isotropic microstructure
- Improved wear and corrosion resistance, through extended alloying possibilities
- Reduction of the number of welds and associated cost and inspection issues
- With the near net shape option, two separate welded parts can be produced in one single step
- The bimetal option, using expensive materials only in functional areas
- Reduction of machining costs, thanks to near net shape or net shape options
- New solutions to produce complex internal cavities, which are difficult or impossible to machine

The benefit of PM HIP technology increases compared to cast or forged parts, especially when:

- Using high value materials such as alloyed steels or nickel- and cobalt-base alloys, because of the near net shape or net shape possibilities
- Producing small series of large and complex shapes
- Where processing costs are high, due to a combination of multiple operations such as machining, welding and inspection.

In summary HIP provides innovative solutions to shorten manufacturing cycle times and to produce small series of parts.

	Welded	Forged*	Cast	PM HIP**
Microstructure in 3 dimensions (Isotropic Microstructure)	poor	poor	good	excellent
Homogeneity	poor	poor	good	excellent
Absence of segregation	poor	good	medium	excellent
Strength properties in 3 directions (Isotropic Strength)	poor	poor	good	excellent
Strength properties level	low	medium	low	high
Near final shape	medium	low	excellent	medium
Large series or repeated requests	medium	good	excellent	medium
Lost form (need of mould/container)	no	no	yes	yes
Material yield	high	low	high	high
Model necessary	no	no	yes	no
Price competitiveness - long series	medium	medium	high	medium
Price competitiveness - short or single unit series	medium	high	high	medium
Delivery time - long series	medium	low	low	medium
Delivery time - short series	medium	high	high	medium

Table 1: Comparison of different manufacturing technologies

\* Forging without die (ie neither open nor closed-die forging)

\*\* PM HIP Near Net Shape components. In the case of PM HIP Net Shape components, the shape precision and reproducibility is excellent, like casting technology.

### 3. THE PM HIP PROCESS

The production of a PM HIP component is leaner and shorter than usual conventional metallurgy processes. The cost of HIP relative to energy and materials costs has decreased by 65% over the last two decades.

**Main process steps are:**

1. Powder manufacturing
2. Container design and manufacturing
3. Container filling with powder and sealing
4. Hot Isostatic Pressing
5. Container removal
6. Post processing operations

These are outlined in the schematic fig.3.1

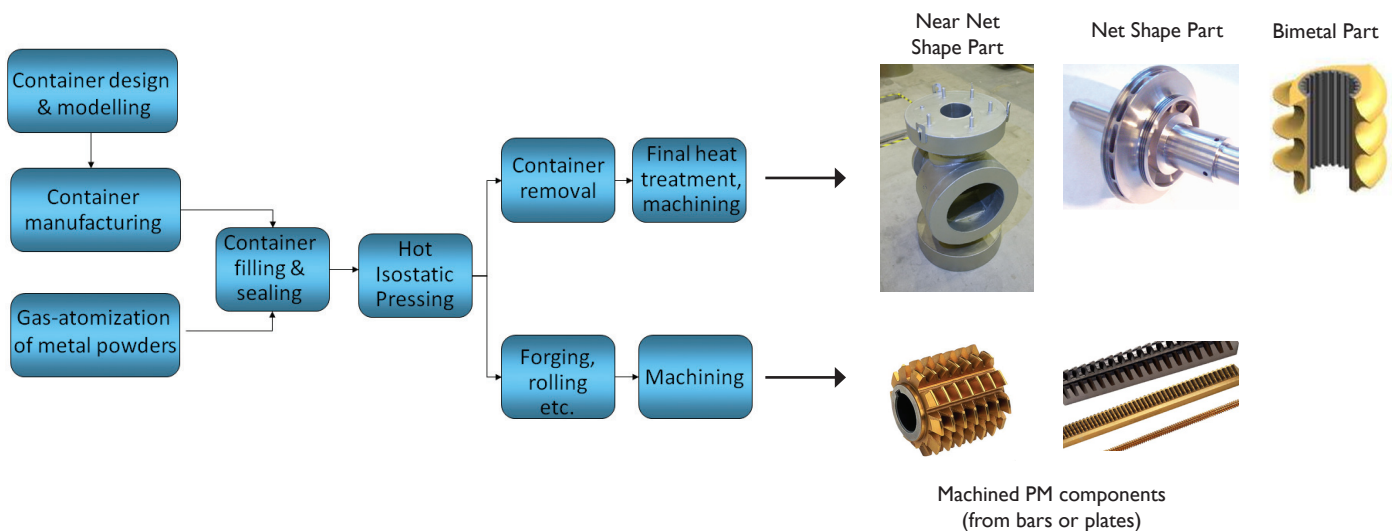

Fig 3.1: PM Production Route



Fig 3.3: Pouring melt into atomiser (courtesy of Atomising Systems)

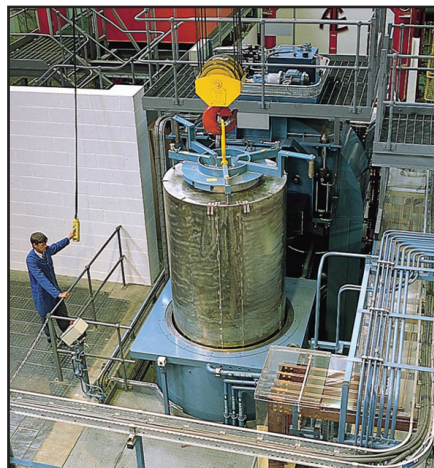

Fig 3.4: Loading container into HIP vessel (courtesy of Bodycote)

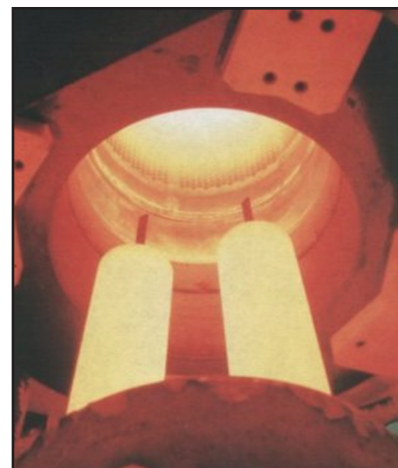

Fig 3.5: Hot loading of HIP unit (courtesy of Kobelco)

### 3.1 Powder Manufacturing

The most suitable metal powders for Hot Isostatic Pressing are produced by gas atomisation because of :

- The perfectly spherical powder shape
- The high fill density, thanks to the spherical shape and particle size distribution
- The excellent reproducibility of particle size distribution, ensuring consistent and predictable deformation behavior
- The wide range of possible alloys, due to the rapid solidification rate.

Note: gas atomisation is a physical method to obtain metal powders, like water atomization or centrifugal atomisation, as opposed to chemical or mechanical methods.

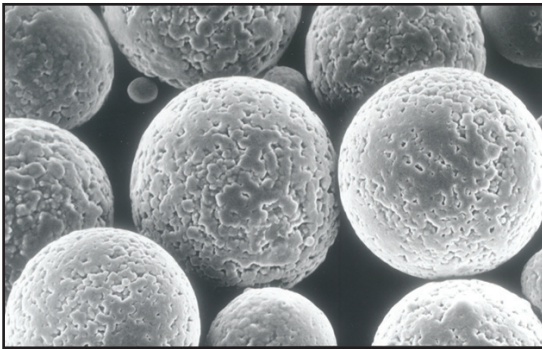

Fig 3.6: SEM picture of gas atomized powders (courtesy of Erasteel)

The gas atomisation process starts with molten metal pouring from a tundish through a nozzle. The stream of molten metal is then hit by jets of inert gas such as nitrogen or argon and atomized into very small droplets, which cool down and solidify when falling inside the atomisation tower. Powders are then collected in a can.

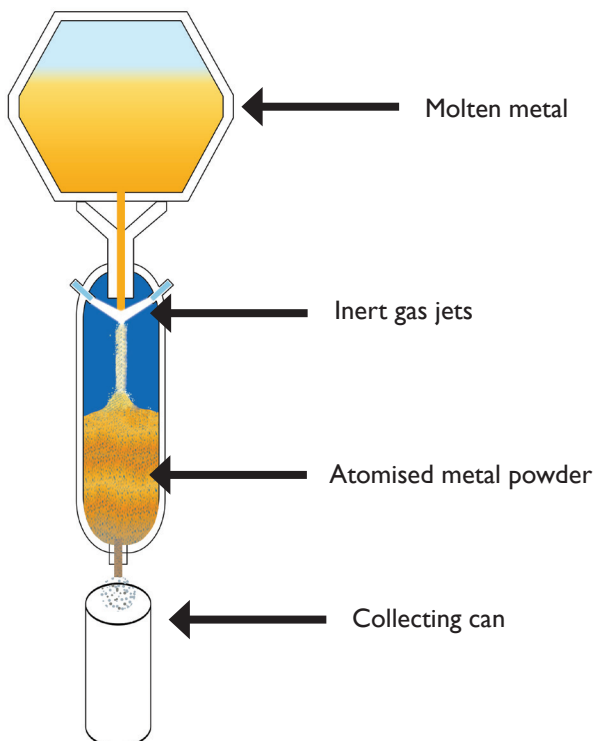

Fig 3.7: Sketch of the gas atomisation process

A wide range of metal powders can be hot isostatically pressed. In addition to standard or customized compositions of steels, nickel-base and cobalt-base alloys, many powders are compacted by hot isostatic pressing such as Titanium, Copper, Lead, Tin, Magnesium and Aluminium alloys. Another benefit of the PM HIP technology process is that new alloy compositions which are impossible to cast or forge can be considered thanks to the rapid solidification process. Indeed, during hot isostatic pressing, the elements do not have time to segregate like in cast parts, because the temperature is below the melting point ( $\sim 0.8 \times T_{\text{solidus}}$ ).

This possibility has been very valuable for metallurgists to invent new alloy compositions for instance in the field of :

- Tool steels for higher wear or temperature resistance
- Stainless steels for high corrosion resistance in difficult environments
- Composite materials e.g. wear resistant metal and ceramic composites

Stainless Steels	Tool Steels	High Speed Steels	Ni-Based Alloys	Co-Based Alloys
17-4 PH 304L, 316L, 410, 420, 440 2205, 2507 254 SMO® 654 SMO® S31254	D2 D7 H13	PM23 PM30 PM60 A11 M4 T15	Ni 625 Ni 690 Ni 718 Astroloy	Co 6 Co 12 Co F

Table 2: A few examples of standard powder alloys used for Hot Isostatic Pressing

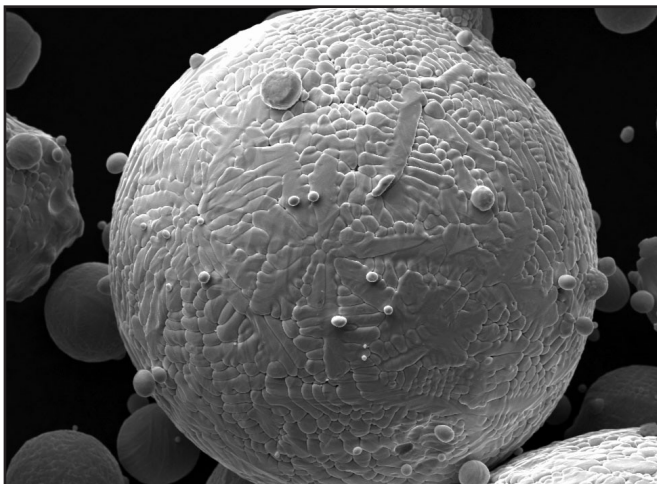

Fig 3.8: SEM picture of gas atomized powder (courtesy of Carpenter Powder Products AB)



Fig 3.9: Gas atomized powders for Hot Isostatic Pressing (courtesy of Erasteel)

### 3.2 Container manufacturing

Container manufacturing involves the following steps:

1. Container sheet cutting and forming/shaping
2. Assembly of steel sheets and optionally pipes and metallic inserts by TIG welding
3. Leak testing, by evacuating the container and introducing helium or argon under pressure. If a leak is detected and located, repair is undertaken.

The integrity of welds is critical, otherwise when the vessel is pressurized, argon will enter the container and become entrapped in the powder mass. The argon will remain in the material and argon-filled pores will strongly deteriorate the mechanical properties.

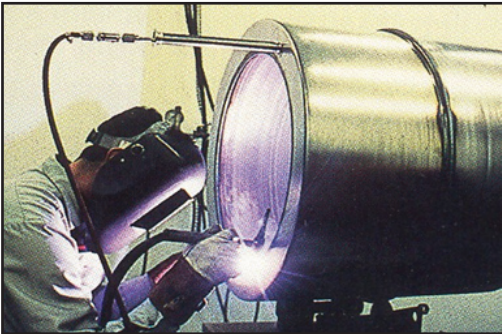

Fig 3.10: Welding of a 2000 kg container (courtesy Bodycote)

### 3.3 Container filling and outgassing

Once assured that the container is leak-free, the powder is introduced via a fill-tube. In order to achieve maximum and uniform packing of the powder, which is necessary to ensure a predictable and consistent shrinkage, a vibration table is used. Vibration will allow the powder to better fill narrow spaces and remote areas. In special cases such as critical aerospace applications, the filling operation is done under inert gas or vacuum to minimize contamination of the powder.

The next step is outgassing to remove adsorbed gases and water vapor. After outgassing, the fill tube is welded to seal the container. The absence of leaks is critical. Otherwise, when the HIP vessel is pressurized, argon will enter the container and become entrapped in the powder mass, creating argon-filled pores with damaging effects on the mechanical properties.



Fig 3.11: Example of container construction with filling / evacuation tubes (courtesy of Rolls Royce.)

### 3.4 The Hot Isostatic Pressing Process

During the hot isostatic pressing process, the temperature, argon-gas pressure and holding time will vary depending on the material types.

After filling and closing, the HIP vessel is evacuated to eliminate the air. Then, while heating up, Argon gas pressure is increased in the vessel. After reaching the calculated pressure, the increase in pressure is done through gas thermal expansion. In the holding time, gas pressure and temperature are constant. After this, a rapid cooling takes place, with decreasing pressure and temperature.

- Chosen temperatures are below approx.  $0.8 \times T$  solidus, to avoid having a liquid phase.
- The gas used is generally Argon but in special applications, other gases or gas mixtures are used.
- The rise in pressure is built up with a compressor
- The gas pressure is equal inside and outside the insulation. But the gas density is higher outside the insulation than inside because of the lower temperature.

Modern HIP systems can feature uniform rapid cooling (URC) which circulates lower temperature gas to cool the part at a controlled rate of up to  $100^\circ\text{C}/\text{min}$ . The HIP quenching technique cuts cycle time dramatically by shortening the cooling stage by as much as 80%. It also provides the benefit of combining heat treatment with HIP in a single step. The uniform rapid cooling restricts grain growth and thermal distortion of the parts and avoids surface contamination by using high purity argon gas.

A HIP treatment cycle usually lasts from 8 hours up to 24 hours.

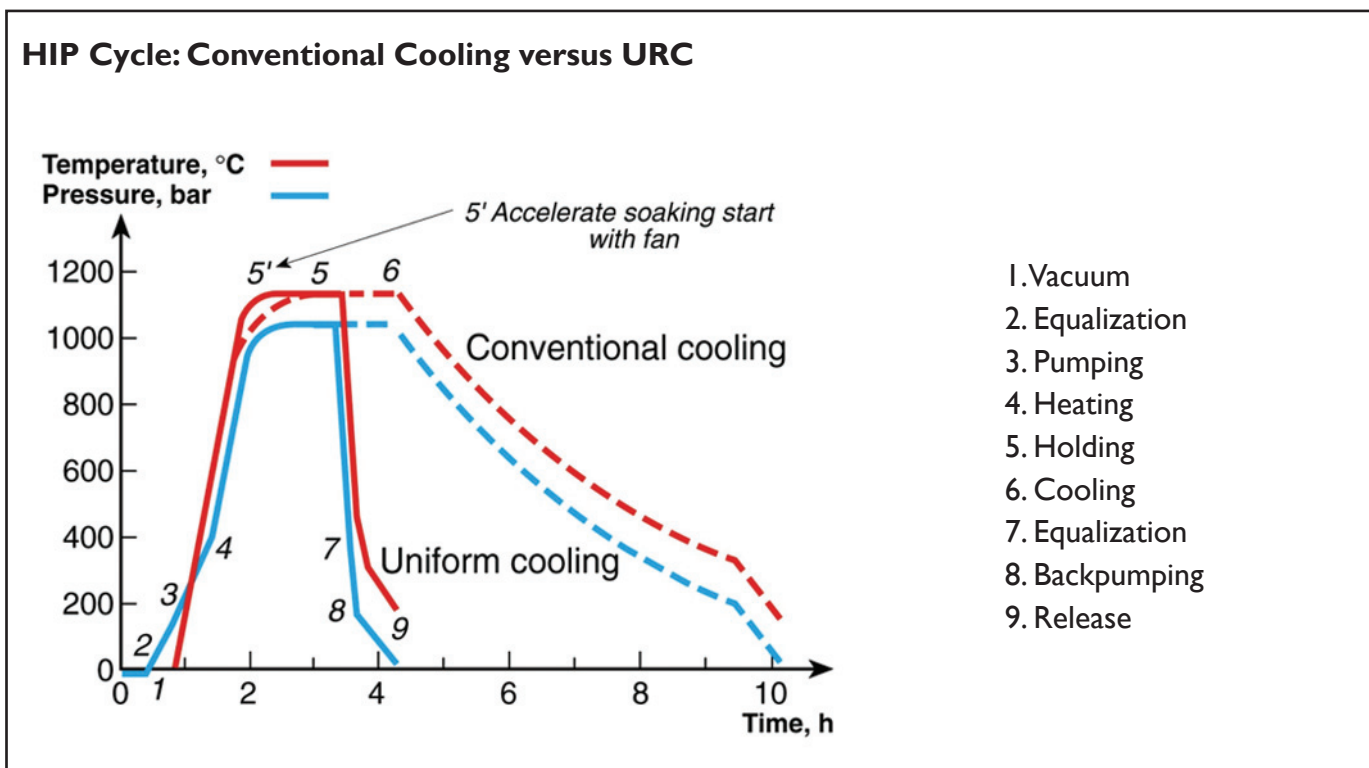

Fig 3.12: Typical HIP cycle with and without uniform rapid cooling (URC) (courtesy of Avure Technologies)

A HIP unit consists mainly of a pressure vessel, a heating system and an Argon gas system. Various HIP constructions are available:

- with or without a frame (For pressures above 100 MPa and HIP diameters above 900mm, frame construction is chosen for safety reasons)
- with or without top screw thread locking systems
- with different heating systems

Molybdenum furnaces are used for temperatures up to 1350°C and carbon graphite/tungsten furnaces up to 2200°C. Inside the pressure vessel, insulation (ceramic fibers and Molybdenum sheets) is used to protect the steel pressure vessel against the heat and to hold the high temperature inside the insulation. The bottom, cover and pressure vessel are water cooled to protect the sealing ring and the vessel against the heat.

In large HIP units, diameters can reach 2200mm and height of more than 4000mm, with a capacity of up to 30 tonnes.

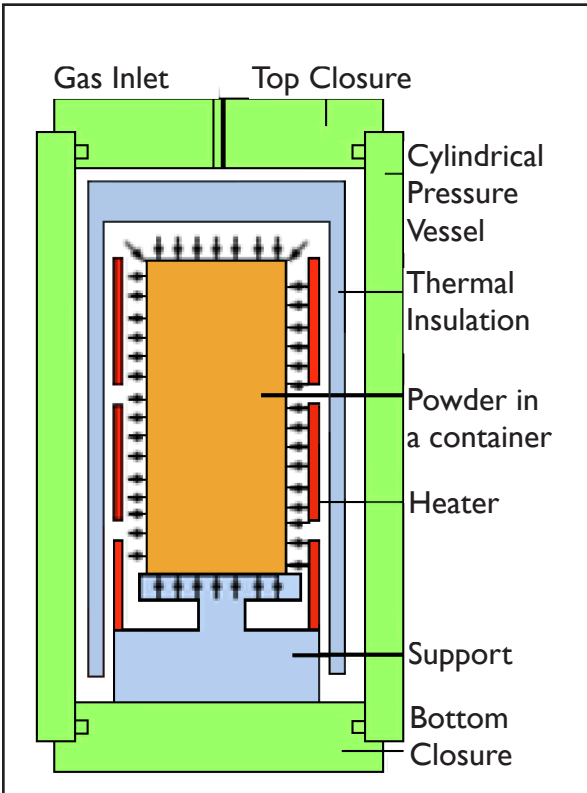

Fig 3.13: Schematic of HIP furnace

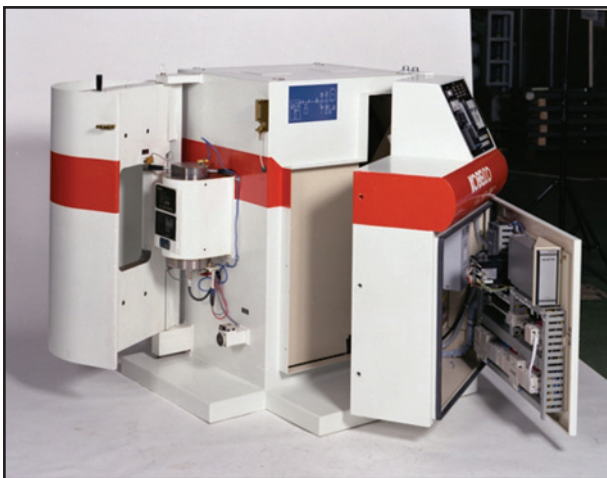

Fig 3.14: Lab Scale HIP unit, (courtesy of Kobelco)



Fig 3.15: Large-scale HIP unit (courtesy of MTC / Avure)

### 3.5 Container removal

After HIP, the container can be removed (when the container is not to be re-used) by :

- Machining
- Acid pickling
- Slipping off

Method	Advantage	Disadvantage	Condition
Machining	Dimensional accuracy	Time consuming and costly	If workable (tool accessibility)
Pickling	No machining demand	Special pickling bath with environmental protection	Only for stainless parts with low carbon steel container
Slip Off	No machining demand	Cost, for the layer	Glass container or separation layer necessary

Table 3: Advantages and disadvantages of various options for container removal

### 3.6 Post processing operations

After container removal, various additional operations can take place, including:

- Heat treatment
- Machining
- Finish grinding
- Surface treatment
- Assembly

### 3.7 Quality and Testing

Depending on the size and value of the parts being made various types of quality testing will be undertaken. Two of the most common are ultrasonic testing and dye penetrant inspection. CAT scanning is also used in critical high value applications.



Fig 3.16: Diffusion bonded parts manufactured via HIP process (courtesy of MTC)



Fig 3.17: Injection extruder, compound (courtesy of Kennametal HTM)



Fig 3.18: Manifold with 1-7 tonnes sections assembled by welding (courtesy of Sandvik Powdermet AB)

## 4. MICROSTRUCTURE OF PM HIP PARTS

Thanks to the rapid solidification process, fine and regular microstructures can be obtained thanks to the PM HIP technology, with strength values similar to those of forged parts.



Cast

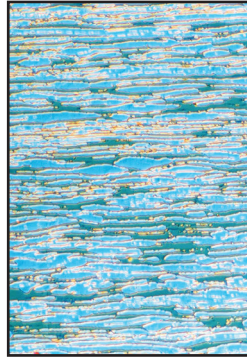

Forged

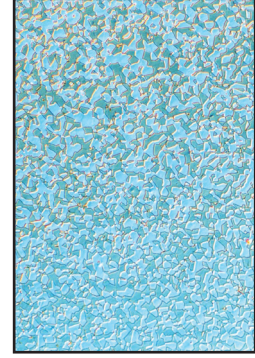

PM HIP

Fig 4.1: Cast, forged and PM HIP microstructures of duplex stainless steel (courtesy of Metso)

The two examples below highlight some of the key benefits provided by this fine and isotropic microstructure.

### 4.1 Stainless Steels

When using HIP with stainless steels companies can obtain components with:

- An excellent combination of toughness and strength
- Isotropic mechanical properties
- Same or better mechanical properties than forged products
- Same or better corrosion resistance than forged products

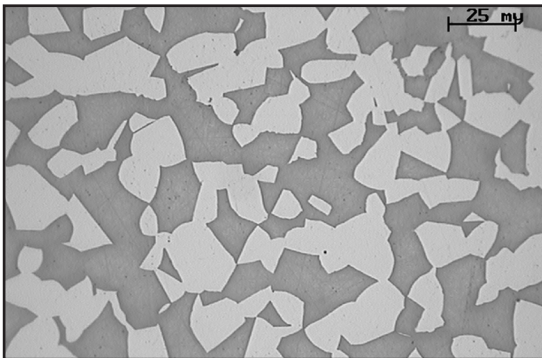

Stainless 2205  
PM HIP

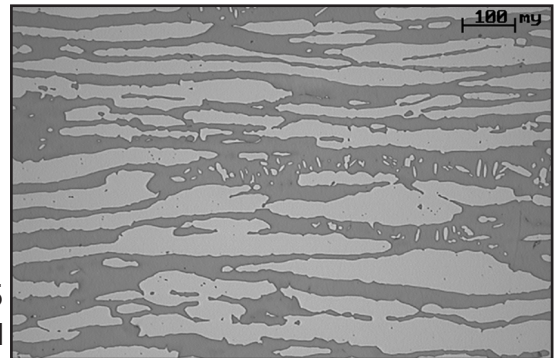

Stainless 2205  
Forged

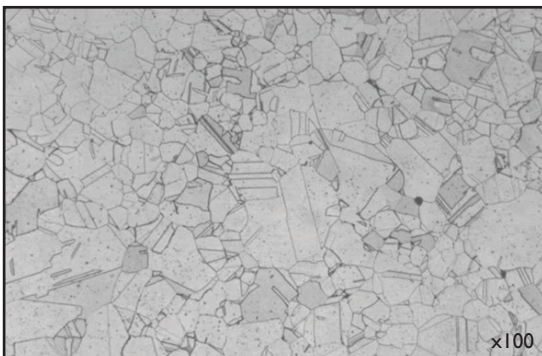

Stainless 316LN  
PM HIP

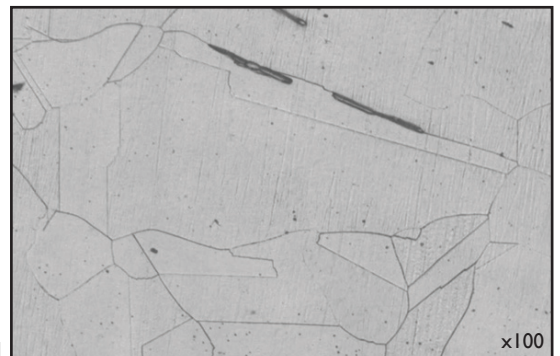

Stainless 316LN  
Forged

Fig 4.2: HIPped and forged microstructures for stainless steels (courtesy of Carpenter (2205) and Areva (316LN))

## 4.2 High Speed Tool Steels

The use of HIP with tool steels enables:

- Longer tool life
- More reliable tool life
- Better fatigue strength
- Better wear resistance due to higher carbide content

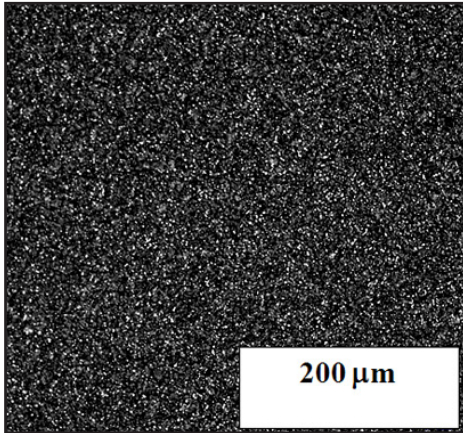

PM HIP HSS

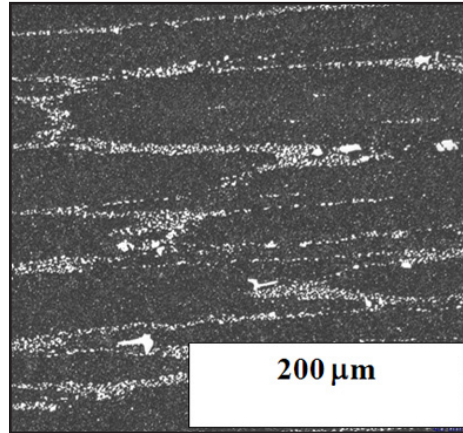

Forged HSS

Fig 4.3: HIPped and forged microstructures for high speed steels (courtesy of Erasteel)

## 5. DESIGN GUIDELINES

### 5.1 Introduction

These design guidelines provide some hints regarding PM HIP component design and manufacturing, so that potential users of the technology understand better the possibilities and issues specific to the PM HIP technology.

Component designers can choose between four different options when considering the PM HIP technology:

- Simple shapes such as round, tubular or flat bar that will either be further machined or forged and rolled
- Near-net-shapes (NNS) which will reduce the need for machining or welding
- Complex net-shapes (NS) which eliminate the need for machining in the functional parts of the component. This provides more freedom in designing components and geometries impossible to machine
- Bimetal or composite construction, where a metal powder layer will be HIPped for instance on a conventional metal substrate, as an alternative to PTA or spraying technologies. In this case, powders are only used in the functional area of the component.

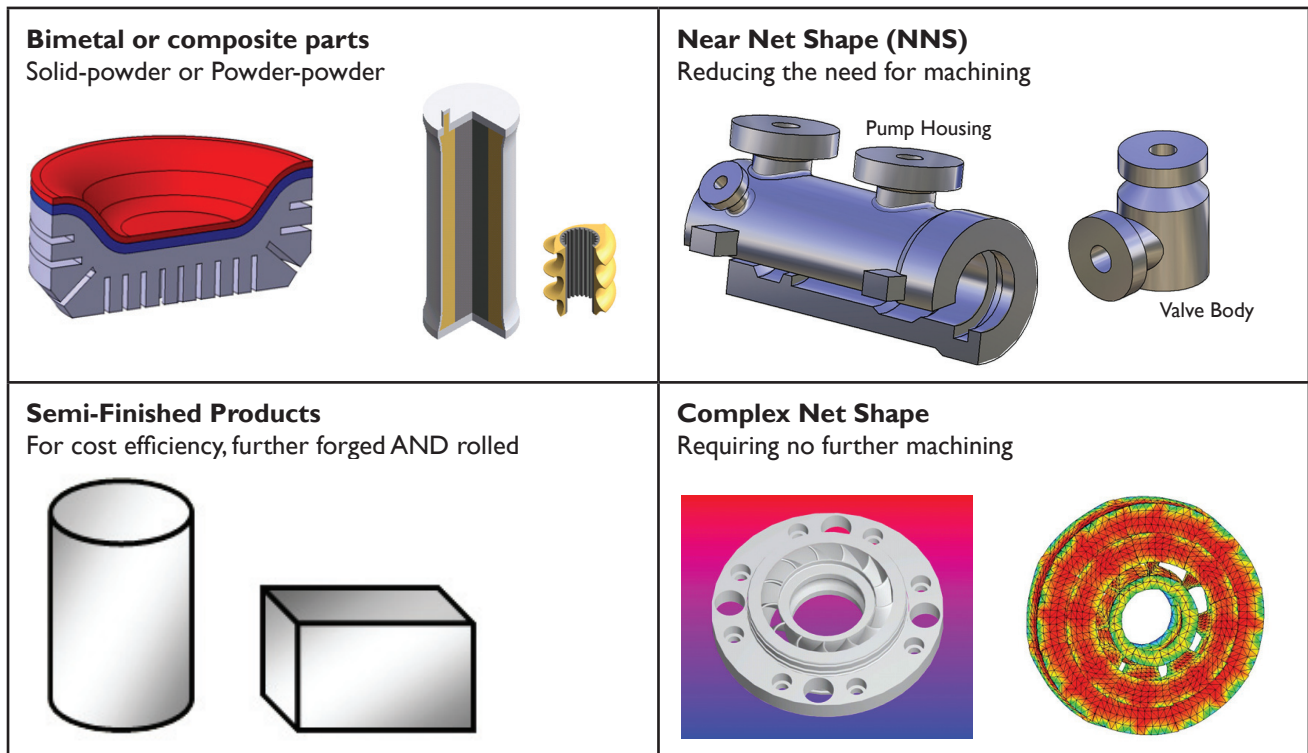

Fig 5.1: Possible options when designing PM HIP components

### 5.2 Computer Modelling

Computer modelling is used, in combination with the experience of HIP design engineers, to simulate accurately the powder densification and shrinkage behavior and to achieve optimum container geometry and dimensions.

Computer modelling allows optimization of the HIP process in particular for complex geometries. It also allows designers to get as close as possible to the finished shape, thereby eliminating expensive machining operations or avoiding any risk of undersize part.

Computer modelling is useful in particular in the case of sharp corners, when there are different container thicknesses or for complex net shape parts.

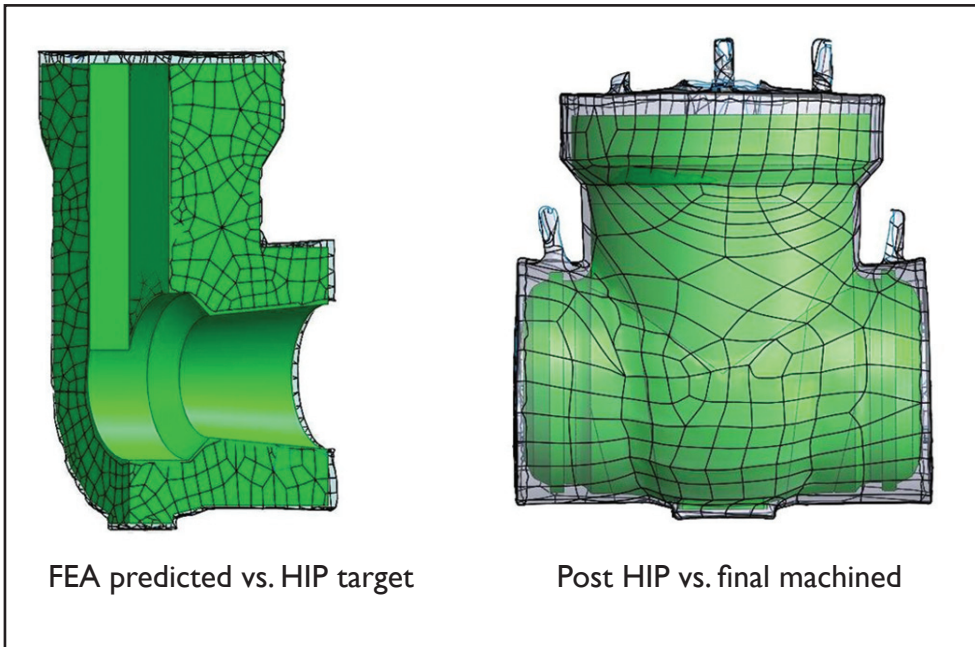

Fig 5.2: Examples of HIP part modelling (Courtesy Bodycote)

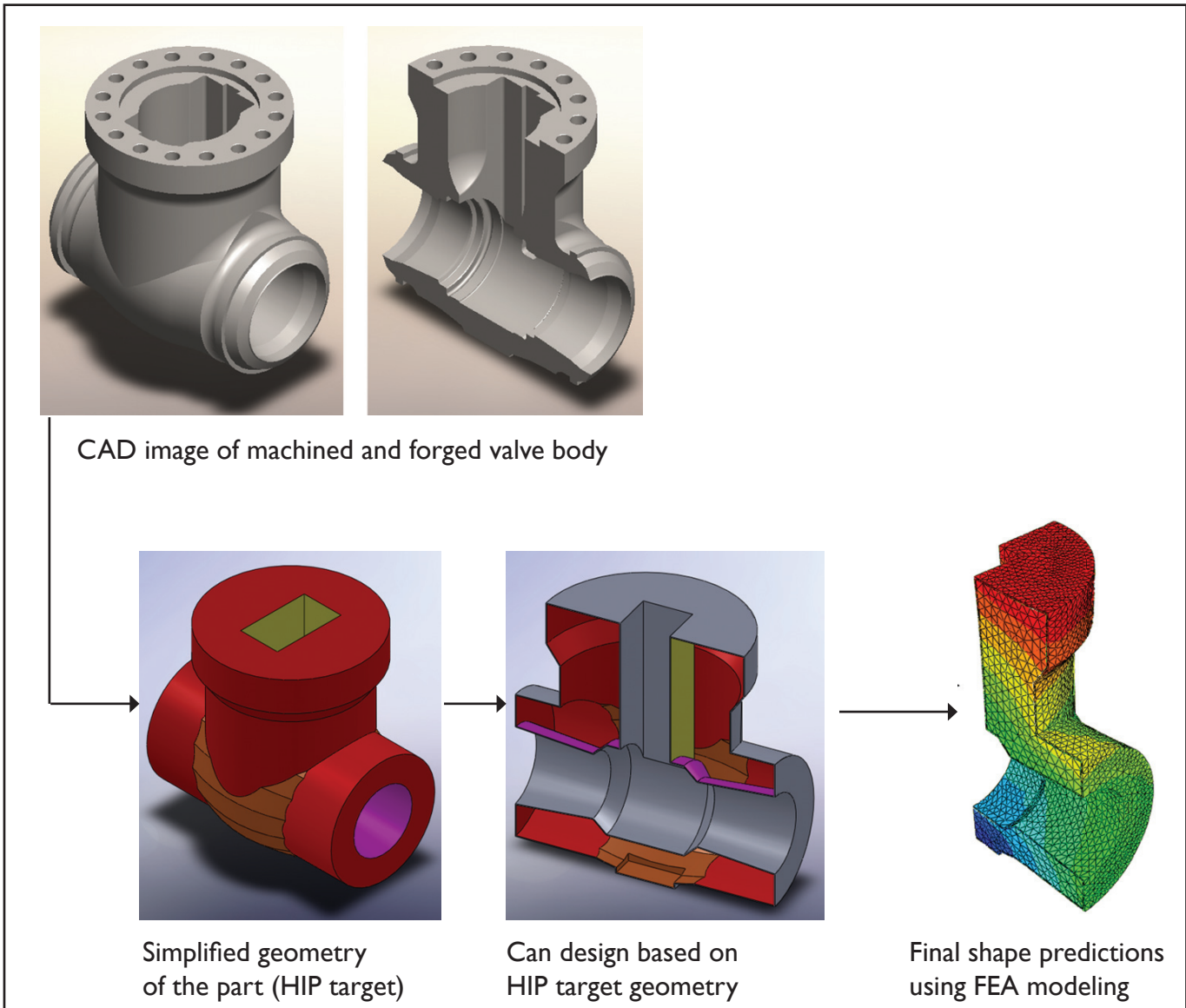

Fig 5.3: HIP component design steps (Courtesy Bodycote)

### 5.3 Container materials

Container materials and thickness are very important parameters when designing a PM HIP part.

The container must satisfy the following considerations:

- It must be strong enough to maintain shape and dimensional control prior to and during HIP.
- It must be soft and malleable at HIP temperature.
- It must be compatible with the powder being processed and not penetrate nor react with the powder mass.
- It must be leak proof both at low and high pressures.
- It must be weldable for secure sealing and be removable after HIP.

The most common container materials are low carbon steels or stainless steels. However in specific cases, containers can be made of high temperature material such as titanium or glass for the compaction of refractory materials. The normal container thickness is between 2 and 3mm.

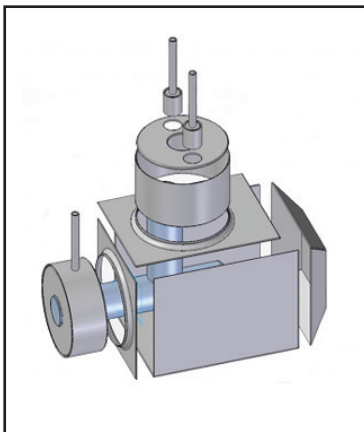

Fig 5.4: Example of Near Net Shape container construction (courtesy of Kennametal HTM)

Container Material	Cost	Deformation		Starting Pressure *	Weldability
		<800°C	>800°C		
Low Carbon Steel	excellent	medium	good	<100 bar	good
Stainless Steel	medium	good	good	>50 bar	good
High Temperature Materials	high	poor	medium	<10 bar	low
Glass	good	poor	good	<10 bar	medium

\*To avoid cracks in the container

Container Material	Handling	Risk of cracks	Container removal		
			Decomposition	Acidification	Machining
Low Carbon Steel	good	low	poor	good	good
Stainless Steel	good	low	poor	poor	good
High Temperature Materials	low	high	poor	poor	poor
Glass	poor	medium	excellent	poor	poor

Table 4: Comparison of different container materials

## 5.4 Container shrinkage

During Hot Isostatic Pressing, the container shrinkage is not isotropic and depends on many parameters such as:

- Container material
- Container overall geometry
- Container thickness
- Positioning of container welds
- Variations in powder fill density within the container

For instance the end plates of a straight cylindrical container will not shrink radially to the same extent as will the cylindrical section. This results in an end effect called « elephant's foot » or « hourglass effect ».

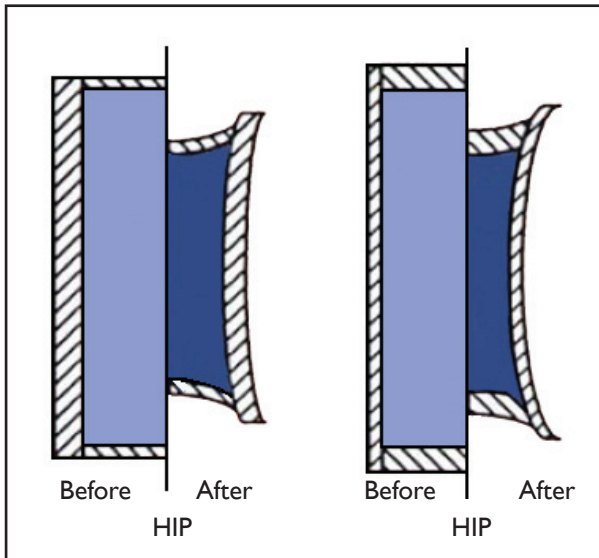

Fig 5.5: Effect of sheet thickness in HIP container design (F.Thümmler, Introduction to Powder Metallurgy, published by Institute of Materials, London, 1993)

## 5.5 Positioning of container welded seams

The positioning of welded seams on the container has a major impact on its deformation behavior during hot isostatic pressing. This must be taken into account when designing PM HIP part as shown in the table below which shows the advantages and disadvantages of each method.

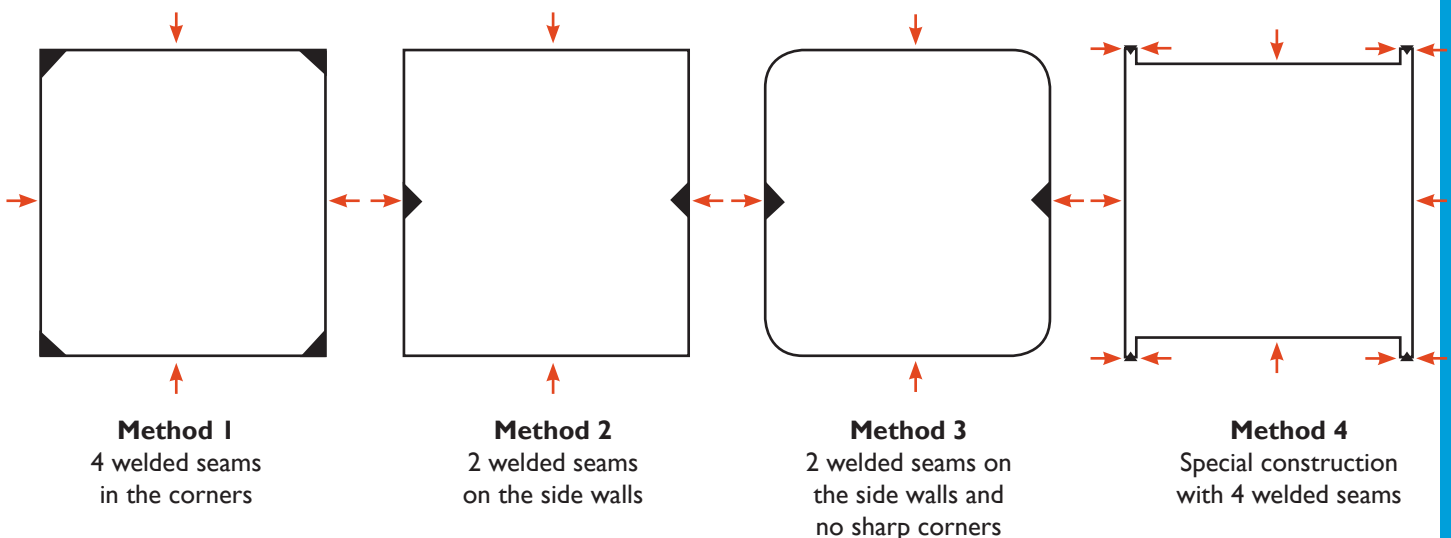

Fig 5.6: Different container construction options

Regular deformation and less welding work are the main benefits of method 3. In method 4, the construction reduces the stress on welded seams because the gas pressure is applied on both sides. Therefore, design methods 3 and 4 are usually preferred to methods 1 and 2.

	Advantage	Disadvantage	Deformation
Method 1	Simple construction	Risk of cracks. Too rigid corners. A lot of welding work.	Strong in the centre
Method 2	Less welding work	Risk of cracking in corners. Need to form sheets in U-shape.	Strong in the centre
Method 3	Regular deformation. Less welding work and lower risk of cracks.	Need to form sheet in U-shape with radius	Regular shrinkage
Method 4	Lower risks of cracks	More welding work. More rigid corner.	Strong in the centre

Table 5: Comparison of different welding seam positions

### 5.6 Container Deformation

After the HIP process, the container will become deformed. This deformation will also vary depending on chosen construction options and the type of contents as can be seen in Fig 5.7 below.

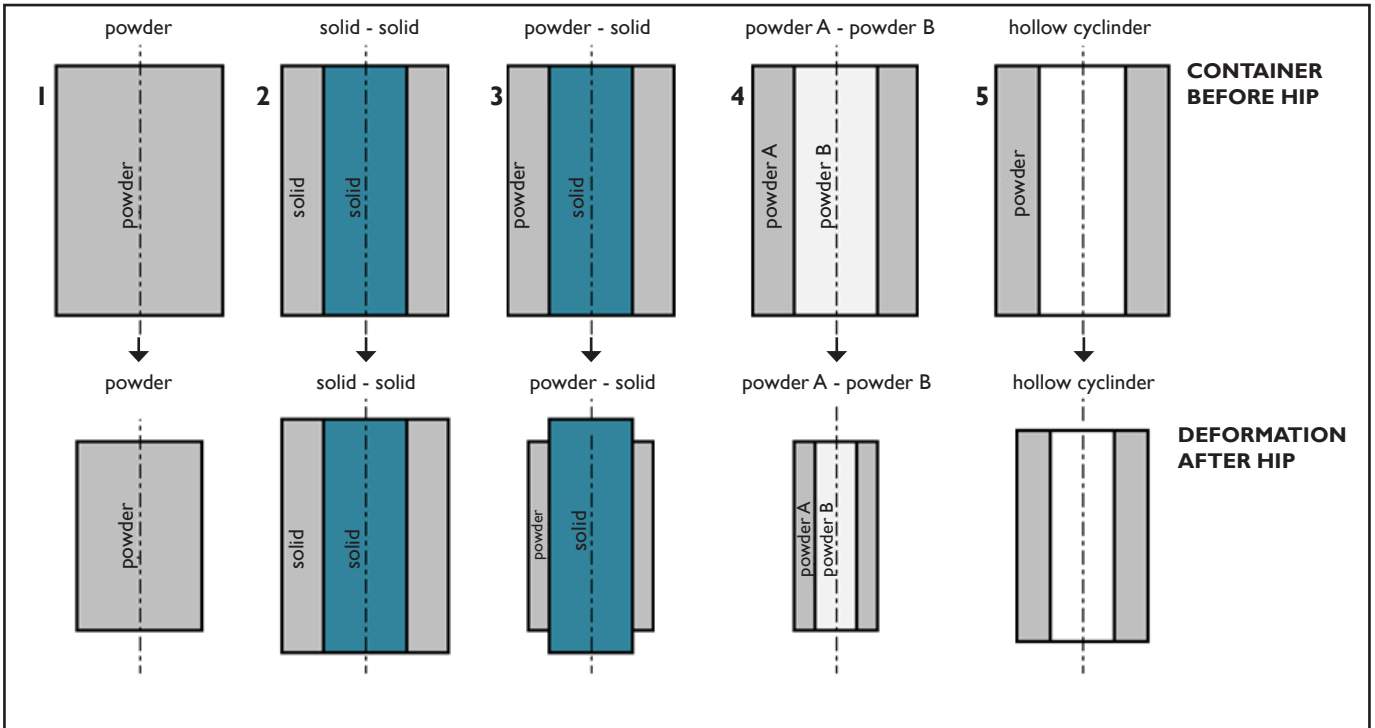

Fig 5.7: Container deformation after HIP depending on chosen construction options

There are five main alternatives as far as the contents of the container are concerned:

1. 100% powder: capsule filled with powder
2. Solid-solid: compound with 2 different solid materials (diffusion bonding)
3. Powder-solid: compound powder with a solid core
4. Powder-powder: compound with 2 different powders
5. Hollow container filled with powder

Their effects on shrinkage for diameter and length are shown in the table below.

Option	Shrinkage	
	on diameter	on length
100% powder	yes	yes
Powder - solid	only for powder	only for powder
Powder - powder	both	both
Solid - solid	no	no

Table 6: Usual shrinkage depending on PM HIP component type. The shrinkage behavior can however sometimes be different in specific cases.

## 5.7 Tolerances of PM HIP parts

Before HIP, the powder volume filling density in a container is approximately 74%.

During HIP, shrinkage and deformation will take place and the tolerance of PM HIP components will depend on many parameters such as:

- Powder filling density
- Powder particle shape
- Powder size distribution
- Consistency of powder size distribution
- Number of welded joints
- Location of welded joints
- Container material
- Container thickness
- Solid material geometry
- Geometry of container
- Geometry of finished part
- Starting pressure
- Filling system

## 5.8 Summary

*PM HIP is a dynamic technology based on advanced R&D and engineering capability. Its versatility and flexibility make it an ideal choice for a wide range of precise and exacting applications.*

*The information here is designed to give an appreciation of the factors involved in manufacturing components using the HIP process. The next step is to contact a HIP service provider (details can be found on the EPMA website at [www.epma.com](http://www.epma.com)) to discuss your requirements in more detail.*

## 6. CASE STUDIES

These case studies are designed to show the range of capabilities of the HIP process; they are all based on real life applications.

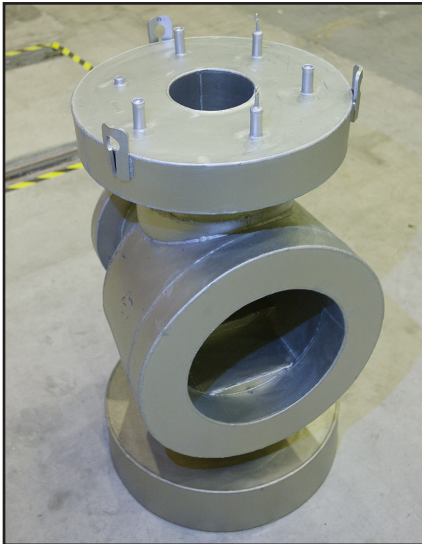

(Courtesy of Metso)

### Valve body for offshore subsea stations

- Category: PM HIP Near Net Shape
- Material: duplex stainless steel UNS31803, UNS32760 and Super duplex and UNS31254, Ni 625 etc
- Part weight: 250 kg to 2 tonnes

#### PM HIP benefits:

- Improved strength properties vs. cast materials
- Easy inspection (reliable inspection by ultrasonic)
- No weld
- Less machining
- Optimized wall thickness
- Clad design also possible
- No need for repair welding
- Fast and reliable manufacturing route



(Courtesy of Sandvik Powdermet)

### Swivel for offshore industry

- Category: PM HIP Near Net Shape
- Material: stainless steel
- Part weight: 9 tonnes

#### PM HIP benefits:

- Complex internal cooling channels
- Weight reduction



(Courtesy of Sandvik Powdermet)

### Manifold for topside & subsea stations

- Category: PM HIP Near Net Shape
- Material: duplex stainless steel UNS31803, UNS32760 and Super duplex
- Part weight: 1 to 4 tonnes
- Part dimensions: Internal diameter 400mm (16 inches)

#### PM HIP benefits:

- Less welds: design with integrated branches
- Less NDE
- Less machining
- Optimized wall thickness
- Clad design also possible



(Courtesy of Sandvik Powdermet)

### Wye-piece for offshore subsea station

- Category: PM HIP Near Net Shape
- Material: Duplex stainless steel UNS S31803
- Part weight: 2 tons

#### PM HIP benefits:

- More freedom in design
- 40% weight reduction vs cast/forged parts to withstand the 250 bar design pressure
- Optimized wall thickness



(Courtesy of Metso)

### Compound raiser pipe for oil refinery cracking plant

- Category: MMC powder-powder PM HIP
- Application: pipe for catalytic material transfer
- Pipe material: High-temperature erosion-resistant metal matrix composite Ralloy DMMC 20 internal cladding

#### Pipe dimensions:

- Thickness of coating 18 mm
- Pipe diameters: OD 625-650 mm, ID 510 mm

#### PM HIP benefits:

- Improved erosion resistance vs. Weld claddings
- Longer lifetime (from 2-3 months to 3-5 years)
- Resistance to high temperature over 600°C
- Resistance to high catalyst flow rate (~ 40 m/s)
- No need of frequent weld repair and shutdowns

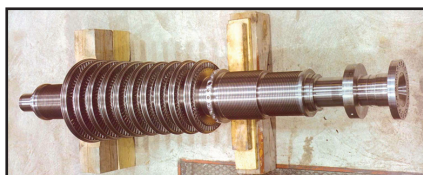

(Courtesy of Sandvik Powdermet)

### Rotor for steam and gas turbine

- Category: PM HIP Near Net Shape
- Material: 12%Cr steel
- Part weight: up to 10 tonnes

#### PM HIP benefits:

- Shorter leadtime
- Dual material capability



(Courtesy of Synertech)

### Impeller for gas compressor

- Category: PM HIP Net Shape
- Material: Nickel-base alloy (Ni 625)
- Part dimensions: diameter up to 1000 mm

#### PM HIP benefits:

- New net shape design possibilities
- Machining, brazing and welds avoided
- Cost savings
- More advanced materials can be used
- Less inspection

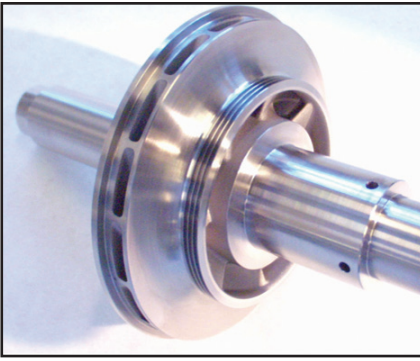

(Courtesy of Aubert & Duval and Snecma)

### Impeller for the cryogenic engine of Ariane V space rocket

- Category: PM HIP Net Shape
- Material: Titanium alloy Ta6V
- Part diameter: 100 mm

#### PM HIP benefits:

- More freedom in vane design
- Shapes impossible to machine
- Mechanical properties at 20 kelvin
- Net shape surfaces
- High dimensional reproducibility



(Courtesy of Sandvik Powdermet)

### Bimetal injector nozzle for diesel engines

- Category: PM HIP Bimetal (powder-solid)
- Application: marine industry
- Operating conditions: 120°C, 600-800 bars
- Material: Co-base powder on steel body
- Part weight: 100 g

#### PM HIP benefits:

- Increased nozzle lifetime
- High temperature corrosion resistance
- Increased mechanical properties (fatigue limit)
- High wear resistance
- Improved machinability and dimensional tolerances

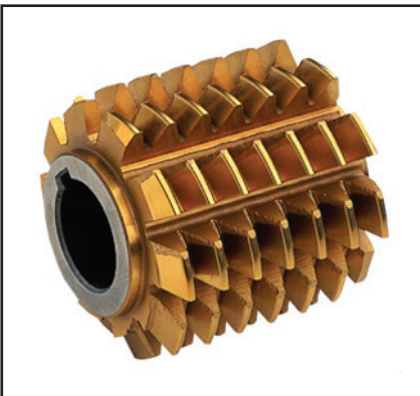

(Courtesy of Erasteel)

### High performance gear cutter for the machining of automotive gears

- Category: PM HIP semi product, further forged, rolled and machined
- Material: PVD coated PM HIP high speed steel
- Product: hob for the rough machining of automotive gears

#### PM HIP benefits:

- High cutting speeds up to 250 m/min and high productivity
- Good surface conditions
- Use in dry conditions reducing coolant use and recycling issues
- Longer tool life (resharpened up to 20 or 40 times)
- High tool reliability, to avoid machine downtime
- Lower overall cutting cost than carbide hob

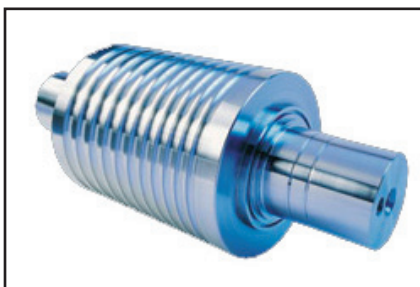

(Courtesy of Erasteel)

### High performance roll for the stainless steel rolling

- Category: PM HIP semi product, further forged, rolled and machined
- Material: PM HIP high speed steel
- Product: rolling mill roll

#### PM HIP benefits:

- Longer roll life
- Improved surface

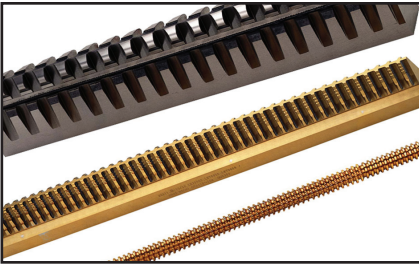

(Courtesy of Erasteel)

### High performance broaches

- Category: PM HIP semi product, further forged, rolled and machined
- Material: PM HIP high speed steel 66 HRC
- Product: round broaches for the internal broaching of steel transmission gears ( $\varnothing$  150mm) and profiled broaches for the machining of aeronautics superalloy turbine disks

#### PM HIP benefits:

- Higher hardness than HSS broach for higher wear resistance
- Higher tool life (3.5 more gears produced per tool vs. HSS broach)
- Increased tool reliability (less micro-chipping) to avoid unplanned machine stops

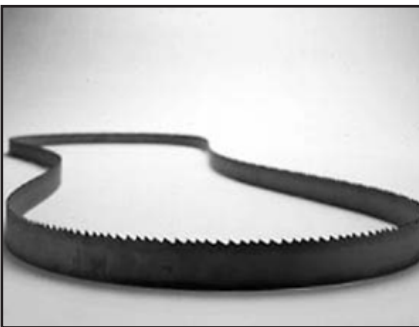

(Courtesy of Erasteel)

### High performance bandsaw

- Category: PM HIP semi product, further forged, rolled and machined/ground
- Material: PM HIP high speed steel
- Product: high performance bimetal bandsaw with PM HIP profiled edge for metal sawing

#### PM HIP benefits:

- Higher productivity
- Higher bandsaw life
- Increased bandsaw reliability

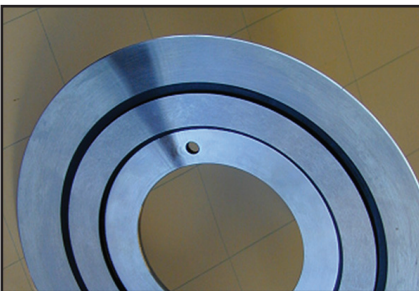

(Courtesy of Metso)

### Slitter knives for paper cutting

- PM HIP semi product, further forged, rolled and machined
- Material: High vanadium PM HIP tool steel with fine grain structure
- Dimensions: OD 190-210 mm, thickness 3-5 mm

#### PM HIP benefits:

- Higher wear resistance
- Sharper edge
- Better surface finish
- Ground to sharpest cutting edge and finest surface quality

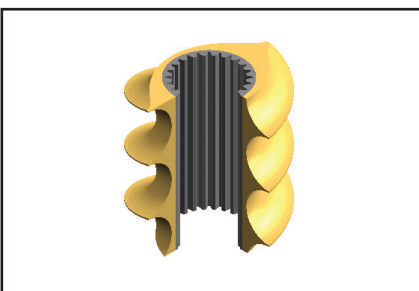

(Courtesy of Kennametal HTM)

### Bimetal screw segment for plastics extrusion

- Category: Bimetal PM HIP semi-product (powder-solid), further machined
- Materials: Tool steels, stainless steels, Ni-based or Co-based powder on a steel substrate
- Part dimensions: diameter up to 500 mm

#### PM HIP benefits:

- Higher performance (steels with more alloy content)
- Combination of wear resistance on the outside and high toughness on the inside
- Higher rotation speed of the extruder
- Easy final machining of the inner contour after heat treatment
- Less powder material than solid PM
- Final screw shape is machined in a bimetal bar (with powder hipped on a conventional steel bar)

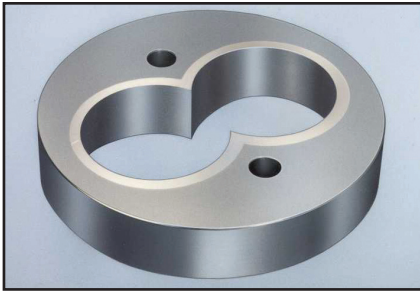

(Courtesy of Kennametal HTM)

### Bimetal cylinder for plastics extrusion

- Category: Bimetal PM HIP semi-product (powder-solid), further machined
  - Application: extrusion cylinder for twin screw extrusion of plastics with abrasive fillers (glass fibers or minerals) or corrosive properties
  - Materials: Tool steels, stainless steels, Ni-based or Co-based powders (coating thickness > 2.5 mm) on a conventional steel substrate
- Part dimensions: diameter up to 850 mm with length up to 2500 mm

#### PM HIP benefits:

- crack-free coating both on bores and apex
- higher performance
- better wear and/or corrosion resistance



(Courtesy of Böhler)

### Backflow check valves for plastics processing

- Category: PM HIP semi product, further forged / rolled heat treated and machined
- Material: PM Plastic Mould Steel

#### PM HIP benefits:

- Extraordinary combination of wear and corrosion resistance
- Excellent polishability
- Unprecedented dimensional stability
- To produce parts of highest precision

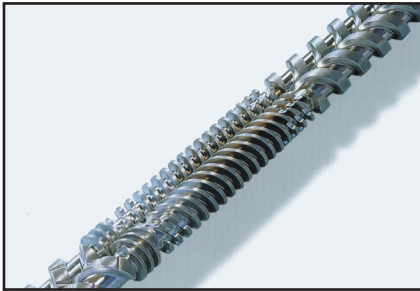

(Courtesy of Böhler)

### Extrusion screw for plastics processing

- Category: PM HIP semi product, further forged / rolled, heat treated and machined
- Material: PM Plastic Mould Steel

#### PM HIP benefits:

- Best wear and corrosion resistance
- Substantially reduced polishing time
- Higher machine economy
- Longer service life
- Higher overall quality

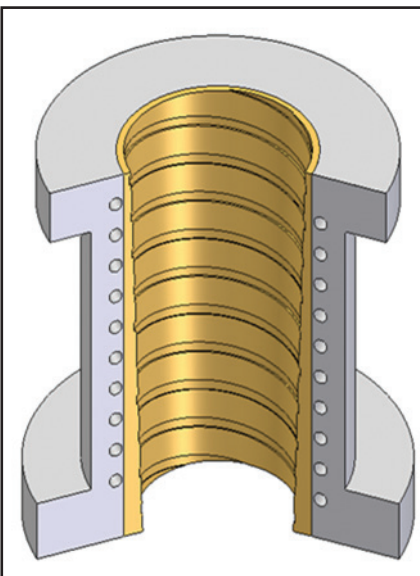

(Courtesy of Kennametal HTM)

### HIP coated cylinder for glue mixing

- Category: Bimetal PM HIP (powder-powder)
  - Product: HIP coated cylinder with integrated cooling system and preshaped inner contour made by powder/powder HIP
  - Materials: Tool steels, stainless steels, Ni-based or Co-based powders (coating thickness > 2,5 mm) on a conventional steel substrate
- Part dimensions: diameter up to 850 mm with length up to 2500 mm

#### PM HIP benefits:

- Complex cooling System can be integrated in one step in the substrate (diffusion bonding)
- Better process control because heating/cooling system is close to processed material
- Less machining costs because of preshaped hard material coating
- Higher performance



(Courtesy of Köppern)

### Clad Grinding Roll for cement processing

- Application: cement industry
- Materials: high alloy tool steel or metal matrix composites
- Roll diameter: from 1000 to 1800 mm

#### PM HIP benefits vs. hardfaced roll:

- Higher wear resistance leading to longer lifetime
- Less maintenance expenditure
- Increased reliability
- Less risk of cracks or chipping



(Courtesy of Metso)

### Suction roll shell for paper machines

- Material: duplex or superduplex stainless steel Duplok 22 and Duplok 27
- Part weight : up to 50 tonnes (in several sections).
- Diameter: up to 1.7 m
- Length: up to 11 m, after welding of the sections

#### PM HIP benefits:

- High corrosion fatigue strength
- High corrosion resistance
- Low residual stress level



(Courtesy of Areva and F4E)

### ITER shield prototype

- Material: 316LN Stainless Steel with 3D bent pipes embedded in a thick layer of 316LN stainless steel powder (150 mm after densification)
- Part weight: 3 tons with overall dimensions 1m x 1m x 0,5 m

#### PM HIP benefits:

- Complex internal cooling channels
- Same mechanical characteristics than wrought material
- US inspection of pipes by the inner side of the tubes



(Courtesy of Metso)

### CERN end cover

- Application: end covers for the dipole magnets of the Large Hadron Collider
- Material: AISI 316 LN Cern specification
- Part weight or dimensions: Weight as machined 60kg, OD 560 mm

#### PM HIP benefits:

- Fully dense and porosity-free to prevent leakage of liquid helium
- High tensile strength at very low temperature (4 Kelvin)
- Tight dimensional tolerances
- Less NDE testing
- No weld
- Less machining

## The European PM HIP Group: - Objectives and Benefits



The European PM HIP Group ('EPHG') which was formed in November 2009 represents the entire sector supply chain from end users, through component makers to raw materials suppliers. The main objectives of the EPHG are fourfold:

- To increase the awareness of the PM HIP technology, with a special (but not exclusive) focus on semi finished, Near Net Shape, as-HIPed and compound PM products.
- To enable the benefits of joint action; for example through research programmes, benchmarking and exchange of statistics
- To improve the understanding of the benefits of PM HIP technology by end users, designers, mechanical engineers, metallurgists and students
- To assist in the development of International Standards for the PM HIP Sector

The group has grown quickly and now comprises over 30 organisations from ten European countries. With two industry-based co-chairmen, the activities of the group have been organised into four sub-groups, each with a “pilot” to ensure follow-up on actions.

By becoming a member of the group, a company gains access to the leading PM HIP network in Europe, as well as benefitting from the full range of EPMA activities in areas such as REACH legislation, Summer schools, publications etc. For further information, please contact Jonathan Wroe at the EPMA secretariat [jw@epma.com](mailto:jw@epma.com).

More details on EPMA services can also be found at [www.epma.com](http://www.epma.com)

epma

[www.epma.com](http://www.epma.com)