



PERGAMON

Renewable and Sustainable Energy Reviews
6 (2002) 537–556

**RENEWABLE
& SUSTAINABLE
ENERGY REVIEWS**

www.elsevier.com/locate/rser

Small hydro power: technology and current status

Oliver Paish *

IT Power Ltd, The Manor House, Chineham Court, Lutyens Close, Chineham, Hampshire RG24 8AG, UK

Received 4 February 2002; accepted 6 February 2002

Abstract

Hydropower, large and small, remains by far the most important of the “renewables” for electrical power production worldwide, providing 19% of the planet’s electricity. Small-scale hydro is in most cases “run-of-river”, with no dam or water storage, and is one of the most cost-effective and environmentally benign energy technologies to be considered both for rural electrification in less developed countries and further hydro developments in Europe. The European Commission have a target to increase small hydro capacity by 4500MW (50%) by the year 2010. The UK has 100MW of existing small hydro capacity (under 5MW) operating from approximately 120 sites, and at least 400MW of unexploited potential. With positive environmental policies now being backed by favourable tariffs for ‘green’ electricity, the industry believes that small hydro will have a strong resurgence in Europe in the next 10 years, after 20 years of decline. This paper summarises the different small hydro technologies, new innovations being developed, and the barriers to further development.

© 2002 Published by Elsevier Science Ltd.

Keywords: Hydropower; Small hydro; Mini-hydro; Micro-hydro; Water power

1. Introduction

Hydropower on a small-scale is one of the most cost-effective energy technologies to be considered for rural electrification in less developed countries. It is also the

* Tel: +44-0-1256-392700; fax: +44-0-1256-392701. Internet: www.itpower.co.uk.

E-mail address: oliver.paish@itpower.co.uk (O. Paish).

main prospect for future hydro developments in Europe, where the large-scale opportunities have either been exploited already, or would now be considered environmentally unacceptable. Small hydro technology is extremely robust (systems can last for 50 years or more with little maintenance) and is also one of the most environmentally benign energy technologies available.

The development of hydro-electricity in the 20th century was usually associated with the building of large dams. Hundreds of massive barriers of concrete, rock and earth were placed across river valleys world-wide to create huge artificial lakes. While they created a major, reliable power supply, plus irrigation and flood control benefits, the dams necessarily flooded large areas of fertile land and displaced many thousands of local inhabitants. In many cases, rapid silting up of the dam has since reduced its productivity and lifetime. There are also numerous environmental problems that can result from such major interference with river flows.

1.1. Small-scale hydro

Small hydro is in most cases ‘run-of-river’; in other words any dam or barrage is quite small, usually just a weir, and generally little or no water is stored. The civil works purely serve the function of regulating the level of the water at the intake to the hydro-plant. Therefore run-of-river installations do not have the same kinds of adverse effect on the local environment as large hydro.

Hydropower has various degrees of ‘smallness’. To date there is still no internationally agreed definition of ‘small’ hydro; the upper limit varies between 2.5 and 25 MW. A maximum of 10 MW is the most widely accepted value worldwide, although the definition in China stands officially at 25 MW. In the jargon of the industry, ‘mini’ hydro typically refers to schemes below 2 MW, micro-hydro below 500 kW and pico-hydro below 10 kW. These are arbitrary divisions and many of the principles involved apply to both smaller and larger schemes.

2. Historical background

Hydropower started with the wooden waterwheel. Waterwheels of various types had been in use in many parts of Europe and Asia for some 2,000 years, mostly for milling grain. By the time of the Industrial Revolution, waterwheel technology had been developed to a fine art, and efficiencies approaching 70% were being achieved in the many tens of thousands of waterwheels that were in regular use. Improved engineering skills during the 19th century, combined with the need to develop smaller and higher speed devices to generate electricity, led to the development of modern-day turbines. Probably the first hydro-turbine was designed in France in the 1820s by Benoît Fourneyron who called his invention a hydraulic motor. Towards the end of that century many mills were replacing their waterwheels with turbines, and governments were beginning to focus on how they could exploit hydropower for large-scale supply of electricity.

The golden age of hydropower was the first half of the 20th century, before oil

took over as the dominant force in energy provision. Europe and North America built dams and hydropower stations at a rapid rate, exploiting up to 50% of the technically available potential. 100's of equipment suppliers sprung up to supply this booming market. Whereas the large hydro manufacturers have since managed to maintain their business on export markets, in particular to developing countries, the small hydro industry has been on the decline since the 1960's. A few countries (notably Germany) have boosted this sector in recent years with attractive policies favouring 'green' electricity supply, but small hydro in general cannot compete with existing fossil fuel or nuclear power stations so that, without environmental incentives to use non-polluting power sources, there has been no firm market for small hydropower in developed countries for many years.

3. Current status

Hydropower, large and small, remains by far the most important of the 'renewables' for electrical power production worldwide. The World Hydropower Atlas 2000 [2], published by the International Journal of Hydropower and Dams, reported that the world's technically feasible hydro potential is estimated at 14,370 TWh/year, which equates to 100% of today's global electricity demand. The economically feasible proportion of this is currently considered to be 8080 TWh/yr.

The hydropower potential exploited in 1999 was 2650 TWh/yr, providing 19% of the planet's electricity from an installed capacity of 674 W. 135 W of new hydro capacity is expected to be commissioned in the period 2001–10. All other renewables combined provided less than 2% of global consumption. As illustrated in Fig. 1,

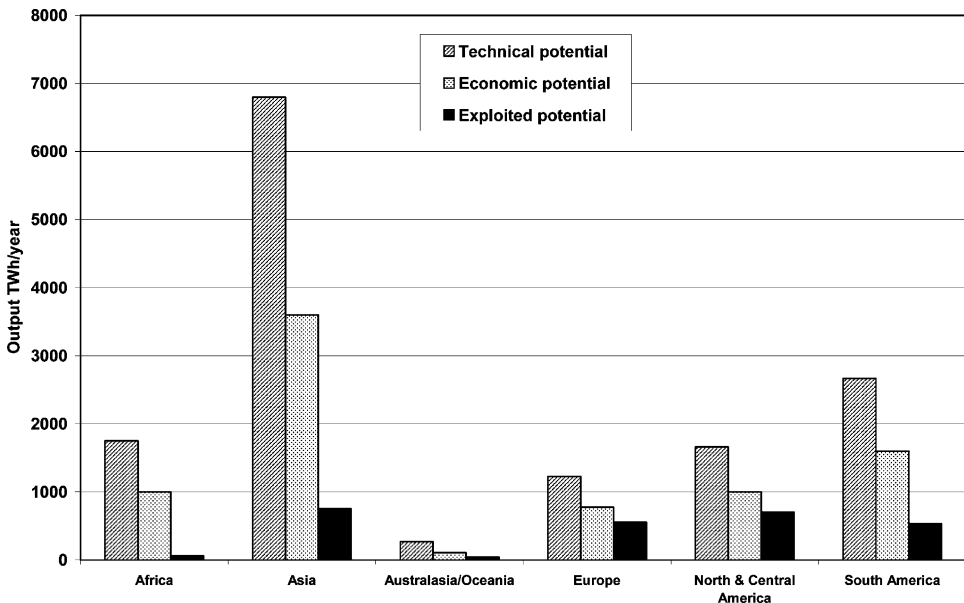

Fig. 1. Exploited hydro potential by continent [2].

North America and Europe have developed most of their economic potential, but huge resources remain in Asia, Africa and South America.

Small hydro (<10 MW) currently contributes over 40 GW of world capacity. The global small hydro potential is believed to be in excess of 100 GW. China alone has developed more than 15 GW, and plans to develop a further 10 GW in the current decade.

3.1. Europe

Hydropower provides about 17% of EU electricity supply. Small hydro provides over 8 GW of capacity and there is an estimated 18 GW of further small hydro potential, including refurbishment projects. The European Commission have announced a target to increase small hydro capacity by 4200 MW (50%) by the year 2010.

The UK has 100 MW of small hydro capacity operating from approximately 120 sites. Most of the remaining potential of interest is located in Scotland and Wales, although England has many 10's of thousands of small low-head sites, previously watermills, which in aggregate amount to over 50 MW of further potential.

4. Basics

Hydro-turbines convert water pressure into mechanical shaft power, which can be used to drive an electricity generator, or other machinery. The power available is proportional to the product of *pressure head* and *volume flow rate*. The general formula for any hydro system's power output is:

$$P = \eta \rho g Q H$$

where P is the mechanical power produced at the turbine shaft (Watts), η is the hydraulic efficiency of the turbine, ρ is the density of water (kg/m^3), g is the acceleration due to gravity (m/s^2), Q is the volume flow rate passing through the turbine (m^3/s), and H is the effective pressure head of water across the turbine (m).

The best turbines can have hydraulic efficiencies in the range 80 to over 90% (higher than most other prime movers), although this will reduce with size. Micro-hydro systems tend to be in the range 60 to 80% efficient.

Figure 2 and Figure 3 illustrate a typical small hydro scheme. Water is taken from the river by diverting it through an intake at a weir. The weir is a man-made barrier across the river which maintains a continuous flow through the intake. Before descending to the turbine, the water passes through a settling tank or forebay in which the water is slowed down sufficiently for suspended particles to settle out. The forebay is usually protected by a rack of metal bars (a trash rack) which filters out water-borne debris which might damage the turbine such as stones, timber, or man-made litter.

In medium or high-head installations water is carried to the forebay by a small canal or 'lead'. Low-head installations generally involve water entering the turbine

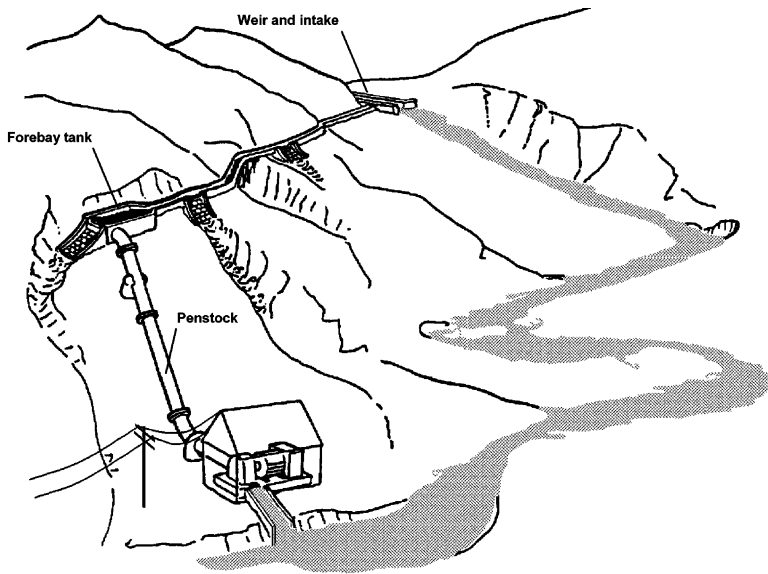

Fig. 2. Small hydro site layout.

almost directly from the weir. A pressure pipe, known as a penstock, conveys the water from the forebay to the turbine. All installations need to have a valve or sluice gate at the top of the penstock which can be closed when the turbine needs to be shutdown and emptied of water for maintenance. When this valve is closed, the water is diverted back to the river down a spillway.

5. Technology

A turbine converts the energy from falling water into rotating shaft power. The selection of the best turbine for any particular hydro site depends upon the site characteristics, the dominant ones being the head and flow available. Selection also depends on the desired running speed of the generator or other device loading the turbine. Other considerations, such as whether the turbine will be expected to produce power under reduced flow conditions, also play an important role in the selection. All turbines have a power-speed characteristic, and an efficiency-speed characteristic. They will tend to run most efficiently at a particular speed, head and flow.

5.1. Classification

Turbines can be crudely classified as high-head, medium-head, or low-head machines, as shown in Table 1. But this is relative to the size of machine: what is low head for a large turbine can be high head for a small turbine; for example a



Fig. 3. This 1.5 W scheme is one of over 50,000 small hydro schemes in China.

Table 1
Impulse and reaction turbines

Turbine type	Head classification		
	High (>50 m)	Medium (10–50 m)	Low (<10 m)
Impulse	Pelton Turgo Multi-jet Pelton	Crossflow Turgo Multi-jet Pelton	Crossflow
Reaction		Francis (spiral case)	Francis (open-flume) Propeller Kaplan

Pelton Turbine might be used at 50 m head with a 10 kW system but would need a minimum head of 150 m to be considered for a 1 MW system.

The main reason that different types of turbine are used at different heads is that electricity generation requires a shaft speed as close as possible to 1500 rpm to minimize the speed change between the turbine and the generator. The speed of any given type of turbine tends to decline in proportion to the square-root of the head,

so low-head sites need turbines that are inherently faster under a given operating condition.

The approximate ranges of head, flow and power applicable to the different turbine types are summarised in the chart of Fig. 4 (up to 500 kW power). These are approximate and dependent on the precise design of each manufacturer.

Turbines are also divided by their principle of operation and can be either *impulse* or *reaction* turbines. The rotor of the reaction turbine is fully immersed in water and is enclosed in a pressure casing. The runner blades are profiled so that pressure differences across them impose lift forces, akin to those on aircraft wings, which cause the runner to rotate. In contrast an impulse turbine runner operates in air, driven by a jet (or jets) of water, and the water remains at atmospheric pressure before and after making contact with the runner blades.

5.2. Impulse turbines

There are 3 main types of impulse turbine in use: the Pelton, the Turgo, and the Crossflow (the latter is also known as the Banki turbine).

The Pelton Turbine (Figure 5) consists of a wheel with a series of split buckets set around its rim; a high velocity jet of water is directed tangentially at the wheel. The jet hits each bucket and is split in half, so that each half is turned and deflected back almost through 180°. Nearly all the energy of the water goes into propelling the bucket and the deflected water falls into a discharge channel below.

The Turgo turbine (Figure 6) is similar to the Pelton but the jet is designed to strike the plane of the runner at an angle (typically 20°) so that the water enters the runner on one side and exits on the other. Therefore the flow rate is not limited by

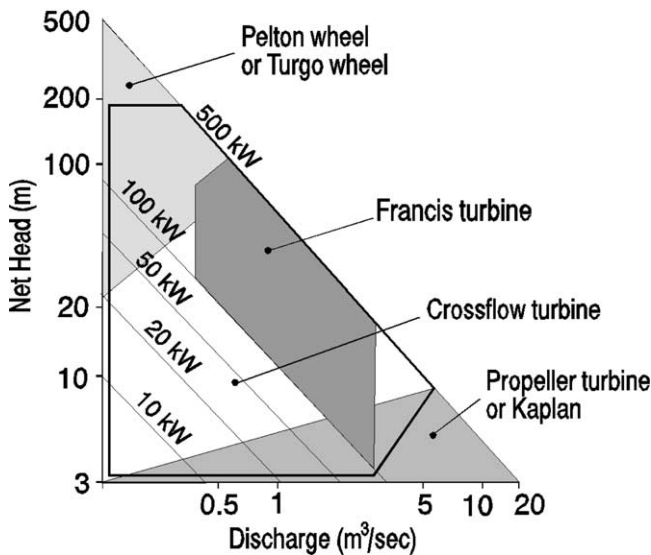

Fig. 4. Head-flow ranges of small hydro turbines [1].

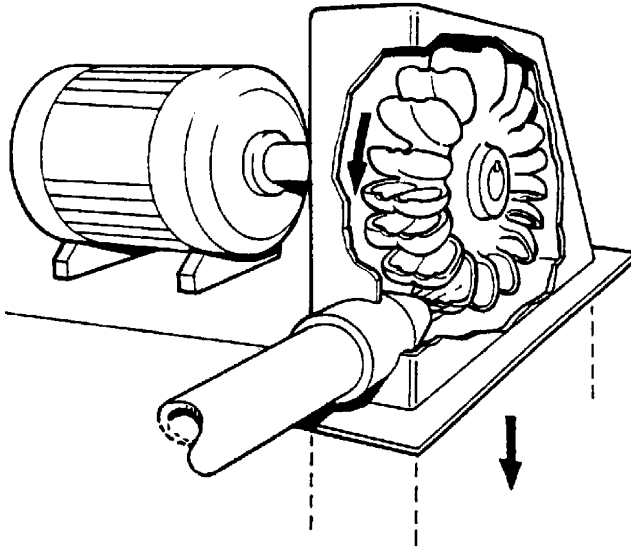

Fig. 5. Pelton Turbine.

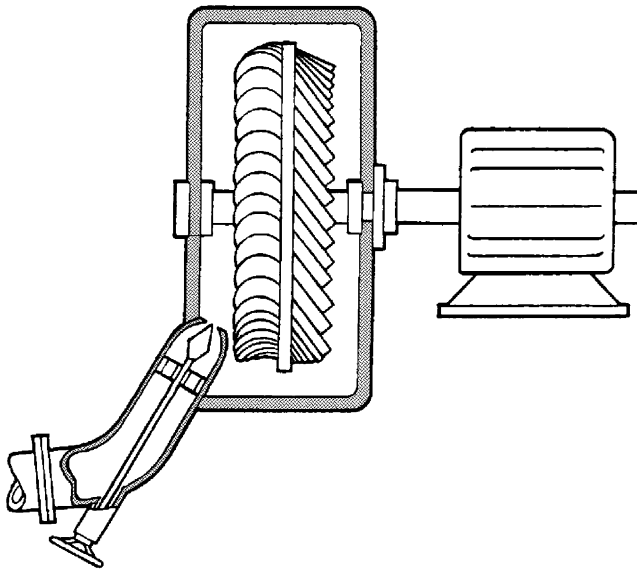

Fig. 6. Turgo Turbine.

the discharged fluid interfering with the incoming jet (as is the case with Pelton turbines). As a consequence, a Turgo turbine can have a smaller diameter runner than a Pelton for an equivalent power.

The Crossflow turbine (Figure 7) has a drum-like rotor with a solid disk at each end and gutter-shaped ‘slats’ joining the two disks. A jet of water enters the top of the rotor through the curved blades, emerging on the far side of the rotor by passing through the blades a 2nd time. The shape of the blades is such that on each passage through the periphery of the rotor the water transfers some of its momentum, before falling away with little residual energy.

5.3. Reaction turbines

Reaction turbines exploit the oncoming flow of water to generate hydrodynamic lift forces to propel the runner blades. They are distinguished from the impulse type by having a runner that always functions within a completely water-filled casing. All reaction turbines have a diffuser known as a ‘draft tube’ below the runner through which the water discharges. The draft tube slows the discharged water and reduces the static pressure below the runner and thereby increases the effective head. The two main types of reaction turbine are the propeller (with Kaplan variant) and Francis turbines.

Propeller-type turbines (Figure 8) are similar in principle to the propeller of a ship, but operating in reversed mode. Various configurations of propeller turbine exist; a key feature is that for good efficiency the water needs to be given some swirl before entering the turbine runner. With good design the swirl is absorbed by the runner and the water that emerges flows straight into the draft tube with little residual angular momentum. Methods for adding inlet swirl include the use of a set

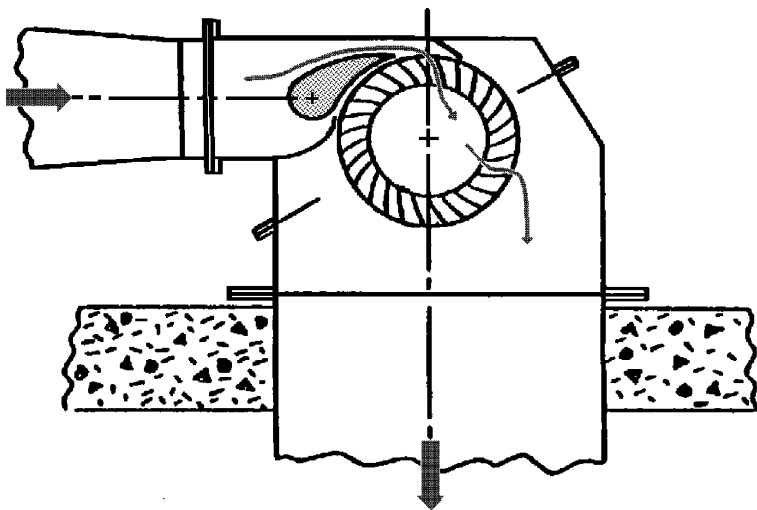

Fig. 7. Crossflow Turbine.

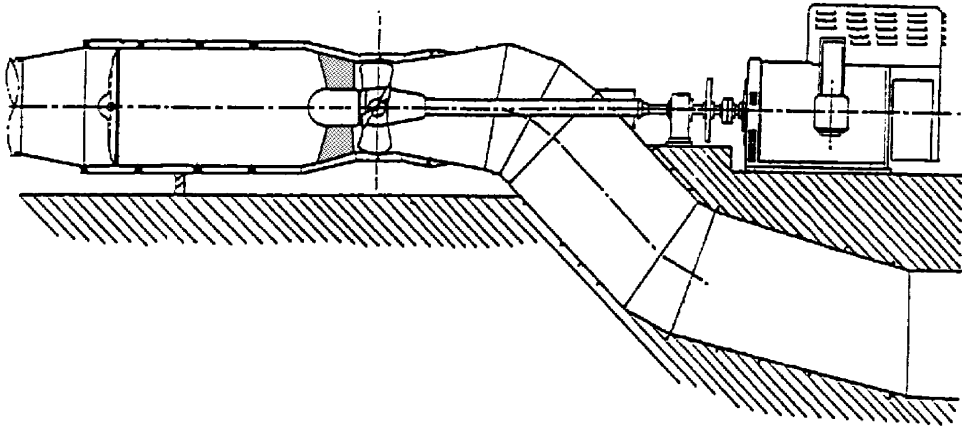

Fig. 8. Tube-type Propeller Turbine.

of fixed guide vanes mounted upstream of the runner with water spiralling into the runner through them. Another method is to form a 'snail shell' housing for the runner in which the water enters tangentially and is forced to spiral in to the runner. When guide vanes are used, these are often adjustable so as to vary the flow admitted to the runner. In some cases the blades of the runner can also be adjusted, in which case the turbine is called a Kaplan. The mechanics for adjusting turbine blades and guide vanes can be costly and tend to be more affordable for large systems, but can greatly improve efficiency over a wide range of flows.

The Francis turbine (Figure 9) is essentially a modified form of propeller turbine in which water flows radially inwards into the runner and is turned to emerge axially. The runner is most commonly mounted in a spiral casing with internal adjustable guide vanes.

Reaction turbines require more sophisticated fabrication than impulse turbines because they involve the use of more intricately profiled blades together with carefully profiled casings. Fabrication constraints therefore make these turbines less attractive for use in micro-hydro in developing countries. Nevertheless, because low-head sites are far more numerous and closer to where the power is needed, work is being undertaken to develop propeller machines which are simpler to construct.

5.4. Relative efficiencies

A significant factor in the comparison of different turbine types is their relative efficiencies both at their design point and at reduced flows. Typical efficiency curves [1] are shown in Fig. 10.

An important point to note is that the Pelton, Crossflow and Kaplan turbines retain very high efficiencies when running below design flow; in contrast the efficiency of the Francis turbine falls away sharply if run at below half its normal flow, and fixed pitch propeller turbines perform very poorly except above 80% of full flow.

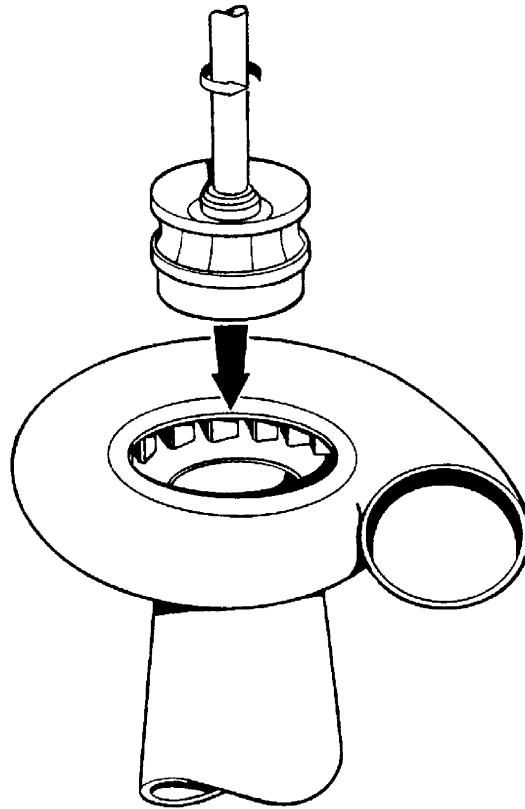

Fig. 9. Francis Turbine.

5.5. Speed control

Many small hydro stations in developing countries are not connected to a national grid, but supply a local town or village. In this case there is no strong grid to hold the generator to the correct frequency (50 or 60 Hz) and an effective speed regulation system is important to ensure that the voltage and frequency remain constant as the electrical load changes through the day.

In some cases a valve is automatically driven by a governing mechanism which adjusts the flow to the turbine to meet variations in power demand. In other cases the turbine always runs at full power and speed control is achieved by adjusting the electrical power output rather than the water power input. In this situation excess electrical power is switched in and out of a ballast load by an *Electronic Load Controller* or ELC. The advent of reliable ELC's in the 1980s radically improved the reliability of small hydro projects remote from the grid.

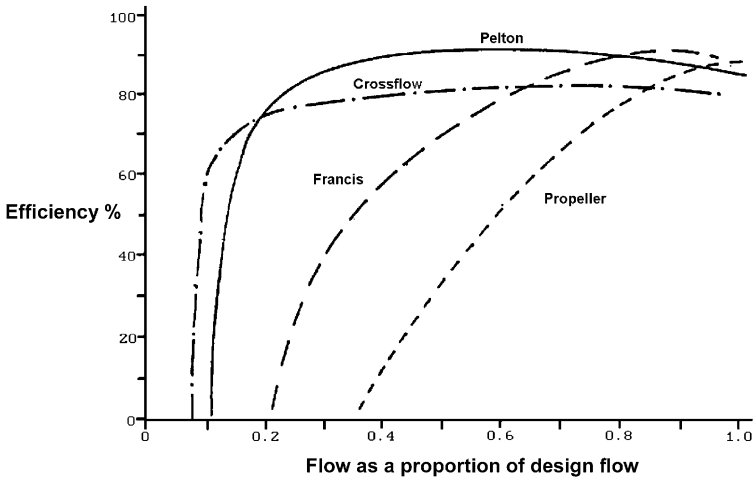

Fig. 10. Part-flow efficiencies [1].

6. Economics

High head hydro generally provides the most cost-effective projects, since the higher the head, the less water is required for a given amount of power, so smaller and hence less costly equipment is needed. Therefore, in mountainous regions even quite small streams if used at high heads can yield significant power levels at attractively low costs. However high head sites tend to be in areas of low population density where the demand for electricity is small, and long transmission distances to the main centres of population can nullify the low cost advantages of remote high head systems. Also high head sites are relatively rare, with most of the best ones in Europe and other developed regions being already exploited. Therefore the greatest scope for expanding the use of small hydro is increasingly with low head sites.

Unfortunately, at present most low head sites are, at best, only marginally attractive economically compared with conventional fossil fuel power generation and for this reason many such potential sites remain to be exploited. For example, the UK has some 20,000 disused water mill sites, all low head, which were used in the past but which have so far not been redeveloped; many other countries have a similar situation.

Paradoxically, under today's conventions for financial and economic appraisal, a new hydro installation appears to produce rather expensive electricity, since the high capital costs are usually written off over only 10 or 20 years. Since such systems commonly last without major refurbishment for 50 years or more, an older hydro site where the initial investment has been paid off is extremely competitive because the only costs relate to the low O&M costs.

Unfortunately, affected by the widespread short-termism of the modern business world, economic analysis of hydropower projects now gives insufficient credit for the exceptionally long lifetime and low running costs of small hydro.

6.1. Costs

Fig. 11 illustrates that installed costs of mini hydro electrification projects tend to be in the range \$2500–3000/kW for the larger schemes. At the smaller end of the spectrum (<500 kW), the costs can vary widely depending on the site and the country involved, and can exceed \$10,000/kW. However costs can be minimised by using indigenous expertise and technology, if available, such that costs below \$1000/kW can be achieved.

7. Projects

7.1. Expanding into developing countries

Small hydro offers today one of the most promising energy resources for long term sustainable development in rural areas of many of the world's poorer countries. However, with a few notable exceptions, progress to date has been disappointing relative to both the potential and the need.

Low-cost micro-hydro systems were developed and tested in Nepal from the mid-1970s onwards, with long-term funding from mainly Swiss and German aid programmes. Simplified designs of crossflow and pelton turbines were transferred to local manufacturers and workshops and the technology was soon also adopted in Sri Lanka, Peru, and Indonesia in particular. In parallel, Electronic Load Controllers (ELC's) using solid-state power electronics were developed in the UK and transferred to these countries in the early 1980's. ELC's were a low-cost means of running off-grid turbines at a fixed speed so as to guarantee 50 Hz generation regardless of the

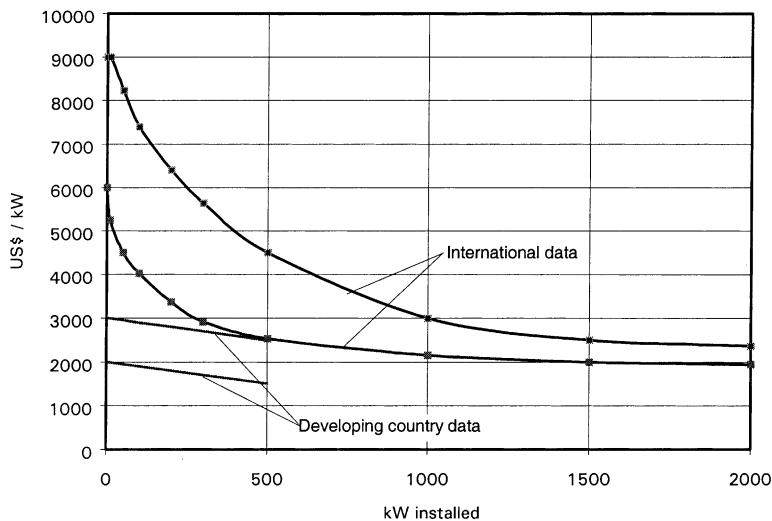

Fig. 11. Range of costs for small hydro projects [5].

increase or decrease in load. The ELC concept has since been copied worldwide and has greatly improved the long-term sustainability of micro-hydro projects in developing countries.

The economic success of these early micro-hydro schemes depended largely on achieving a high load factor and using the scheme for income-generating activities (as in Figure 12). The first expressed demand for power is usually domestic lighting (plus TV and radio), but lighting alone is rarely enough to justify a new micro-hydro plant because the load factor rarely exceeds 10% and further demand only builds up slowly (typically less than 20%/year). Increasing commercial and industrial end-uses, ie. raising the productivity of local labour, is the most direct way of justifying a new scheme on economic grounds. Hence if lighting is wanted by night, then this must be ‘paid for’ by using hydropower for productive activities by day. Studies in Nepal have shown that rural electrification alone has had minimal impact on agricultural or industrial production. The most cost-effective use of hydropower in Nepal has been through mechanical end-uses [3].

As a result of these first developments, the crossflow and pelton turbines have become by far the most widely adopted turbine technology for local manufacture in developing countries. This is also because impulse turbines in general are better suited than reaction turbines to micro-hydro applications in developing countries. They have the following advantages:

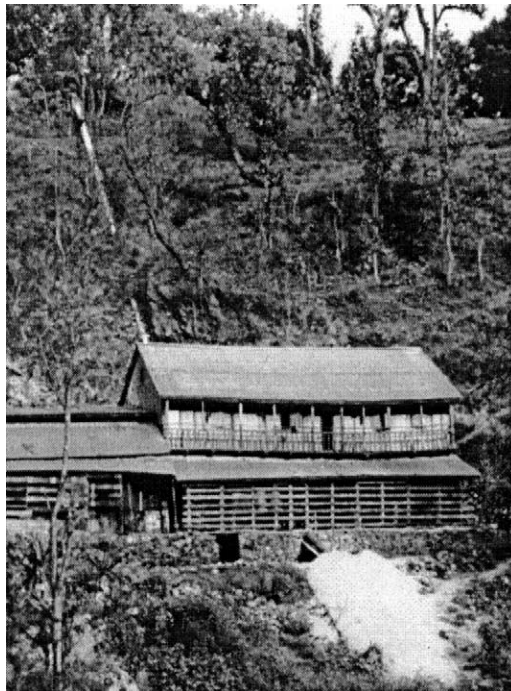

Fig. 12. This 12 kW micro-hydro scheme in Nepal is used for rice-hulling and oil-exPELLING by day, and village electrification by night.

- more tolerant of sand and other particles in the water;
- better access to working parts;
- no pressure seals or glands around the shaft;
- easier to fabricate and maintain;
- better part-flow efficiency.

The major disadvantage of impulse turbines is that they are mostly unsuitable for low-head sites because of their low specific speeds; too great an increase in speed would be required of the transmission to enable coupling to a standard alternator. On very small sites (for example Figure 13), the Crossflow can be used down to 4 m and small Turgos or multi-jet Peltons down to perhaps 20 m.

Although it has the lowest peak efficiency of the common turbine types (70–80%), two particular attractions of the crossflow have led to its widespread popularity for micro-hydro applications. Firstly, it is a design suitable for a wide range of heads and power ratings (see Fig. 4). Secondly it lends itself to simple fabrication techniques, a feature which is of particular importance to developing countries. The runner blades, for instance, can be fabricated from lengths of pipe cut into strips. Paradoxically, following its proven success in developing countries, the crossflow turbine is finally finding favour in micro-hydro schemes in Europe, despite the concept having originated there in the 1920's.



Fig. 13. Low cost crossflow turbine in India. This 5 kW machine, designed and disseminated by IT Power of the UK, is used for rice-hulling and electricity generation.

7.2. Focus: China [4]

China deserves a special mention when discussing small-scale hydropower. China has 17% of the earth's hydropower resource and has installed around 40% of the world's small hydro capacity. Since the establishment of the Peoples' Republic in 1949, approximately 15,000 MW of schemes less than 10 MW have been constructed, with more than 80% of this coming on-line since the mid 1970s. Around half (7000 MW) of this capacity is below 500 kW. The economic small hydro resource in China is estimated to exceed 70 GW [4].

The Government has major plans for continued rural electrification with small hydro and is perhaps unique in promoting a national policy which places equal importance on hydro and thermal power, and which devotes as much attention to small hydropower as to medium and large scale projects.

In recent years the rate of commissioning of new small hydro capacity has been around 1000 W per year, supporting a large network of factories supplying mass-produced turbines (Figure 14). Small hydro is seen as a key environmentally-sound solution for improving the economic growth rate in China's vast rural areas, many of which have rich, undeveloped hydro resources. As many as 80 million rural Chinese people still do not have access to electricity.

However, while china undoubtedly has the lead in terms of operational experience, its indigenous technology is less advanced than 'western' equipment, having been designed and 'standardised' in the 1960's with little further improvement since.

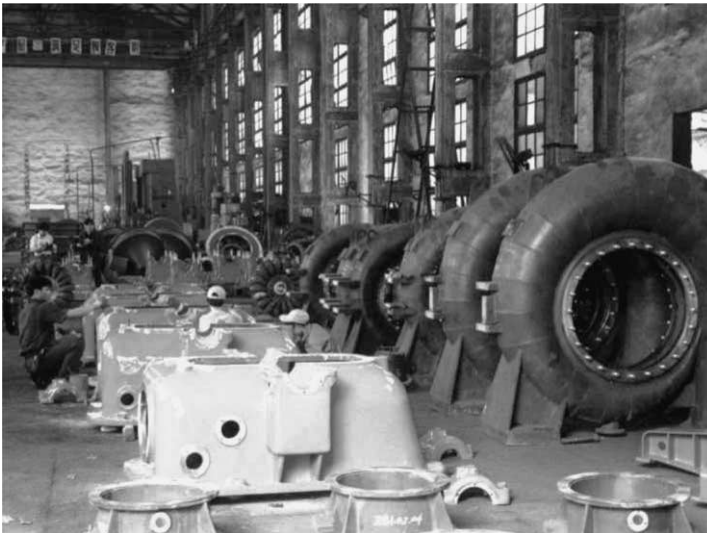

Fig. 14. Mass production of standardised Pelton and Francis turbines in China.

8. Future directions

8.1. Innovation and cost-cutting

Although manufacturers rightly pride themselves in the high efficiency and quality of their turbines, these are irrelevant if the machinery is unaffordable. In the final analysis, it is the energy delivered versus the investment cost which is the key parameter.

Much of the technical effort to develop small hydro in recent times has therefore focused on measures to improve cost-effectiveness of the technology. To this end, a number of developments show promise, which can only be summarised very briefly here:

- *Standardisation*: moving away from designing a new system for every site by offering standard sizes of turbine, which share components wherever possible.
- *Innovative use of existing civil works*: designs are emerging which avoid much of the civil construction costs by cleverly utilising the civil works already in place at existing river structures, for example siphonic turbine designs.
- *Variable speed operation of low head turbines*: recent developments in power electronics allow a turbine and generator to be run at varying speeds (instead of synchronous speed needed to produce the mains standard of 50 Hz AC). This permits simpler propeller turbines to be used instead of Kaplans.
- *Electronic control and telemetry*: permits unattended operation of hydro-plants.
- *Submersible turbo-generators*: these run usually as a ‘bulb’ propeller turbine with the generator submerged and sealed in the flow; this can eliminate the need for a power house.
- *New materials*: plastics, new anti-corrosion materials, etc. offer possibilities for more cost-effective turbines, penstock pipes, bearings, seals etc.
- *Computer optimisation of small systems*: permits more accurate and rational sizing of a system to maximise the financial return from a site (rather than maximising energy capture).
- *Inflatable weirs*: water-filled rubber weir crests are being used to raise the available head on low-head sites; they can deflate to allow flood waters to pass through.
- *Innovative turbines*: various novel types of turbine, or modifications to existing types, have been trialled, and significant work has been done on using mass-produced pumps running backwards as turbines.
- *Simplification and improvement of trashracks*: innovations such as self-cleaning trashracks or self flushing intakes are being developed to reduce the problem of intake screens becoming clogged with debris.
- *Improved techniques to avoid interference or damage to fish*: perhaps the most common objection to new hydro systems is that they may harm fish. Novel forms of fish ladder and physical or ultra-sonic screening promise more cost-effective solutions.

8.2. *Barriers to small hydro developments in europe*

Regrettably, there seem to be an increasing number of institutional and environmental barriers to be faced in gaining permission to implement new small hydro schemes within the EU. In some countries, this has brought the industry to a stand-still.

Gaining permission to occupy land and abstract water from a river has always been necessary. Developers now have to invest in detailed analyses and expensive hardware to prevent adverse effects on fishing; they have to counter a range of perceived conflicts with river-based leisure interests, and prove that there will be no impacts to the river bed, river banks, flora and fauna, land drainage, or the ability to remove flood waters. All these barriers have a sound basis and can be overcome by good scheme design, but at a cost and time delay which makes projects unviable. Difficulties in gaining affordable connections to the grid are also common, although this situation is tending to improve.

Turbines need to be protected from all the debris that is commonly found in rivers. The hydro-plant operator is usually prohibited by law from disposing of the rubbish collected on his screen back into the river. Therefore garbage disposal by a hydro installation can serve to clean up a river considerably for the benefit of everyone downstream, but usually at the considerable expense of the operator.

There are a few other environmental impact issues relating to reduced oxygenation of the water, erosion immediately downstream of the turbine draft tubes, electrical machinery noise, the general appearance of an installation, etc. However all these problems are capable of being mitigated by using suitable design techniques and the end product is a remarkably long-lasting, reliable and potentially economical source of clean energy.

9. **Conclusions**

In summary, the main advantages of small-scale hydropower are:

- it is a much more concentrated energy resource than either wind or solar power
- the energy available is readily predictable
- power is usually continuously available on demand
- no fuel and only limited maintenance are required
- it is a long-lasting technology
- it has almost no environmental impact.

Against these, the main shortcomings are:

- it is a site-specific technology; sites that are both well-suited to the harnessing of water power and close to a location where the power can be exploited are not all that common
- there is always a maximum useful power output available from a given hydro

power site, which limits the level of expansion of activities which make use of the power

- river flows often vary considerably with the seasons, especially where there are monsoon-type climates, and this can limit the firm power output to quite a small fraction of the possible peak output
- there can be conflicts with fisheries interests on low-head schemes, and with irrigation needs on high head schemes
- lack of familiarity with the technology and how to apply it inhibits the exploitation of hydro resources in many areas.

However, where a hydropower resource exists, experience has shown that there is no more cost-effective, reliable and environmentally-sound means of providing power than a hydropower system. There are many hilly or mountainous regions of the world where the grid will probably never reach, but which have sufficient hydro resources to meet basic domestic and cottage industry needs of the local populations. However for this potential to be realised will require significant efforts and resources to be allocated towards:

- technology transfer of appropriate turbines to local manufacturers
- loan finance for site-owners and developers
- technical support to the developers
- training in operation, maintenance, repair, and business management.

This has been successfully achieved in a few selected countries. The opportunity is far greater.

10. Societies and organisations

1. The British Hydropower Association

Unit 12 Riverside Park

Station Road

Wimborne

Dorset BH21 1QU

www.brit-hydro.cwc.net/

2. The European Small Hydropower Association

Renewable Energy House

26, rue du Trône

B-1000 Brussels

Belgium

email: www.esha.be

3. The International Network for Small Hydropower

IN-SHP

P.O. Box 202

Hangzhou 310002

China

email: hic@mail.hz.zj.cn

www.digiserve.com/inshp

10.1. Web-sites

For a wide-ranging set of links to many useful micro-hydro web-sites, try:http://www.geocities.com:0080/wim_klunne/hydro/link.html

10.2. Bibliography—Introduction

There are very few books that have focused on the issues relating specifically to small-scale hydropower. Ref. [7] is the most comprehensive technical guide to small-scale hydropower projects, though focusing mainly on projects <500 kW. It covers the whole topic from initial site survey, through to equipment selection and installation. Ref. [8] is an excellent review of the institutional, economic and social issues that have affected the development of small-scale hydro in developing countries, and recommends the best way forward for new programmes. Readers looking for the hydraulic theory of turbines should examine traditional hydraulics engineering textbooks; although these are usually written with large-scale projects in mind, the basic theory for a small turbine is no different to that of a large turbine.

References

- [1] Paish Oliver. *Micro-Hydro Power: Status And Prospects*, Journal of Power and Energy, Professional Engineering Publishing, 2002.
- [2] Fraenkel P, Paish O, Bokalders V, Harvey A, Brown A, Edwards R. *Micro-Hydro Power: a guide for development workers*. London: IT Publications Ltd, 1991.
- [3] *International Journal of Hydropower and Dams: World Atlas*. Sutton: Aquamedia Publications, 2000.
- [4] Fulford S, Mosley P, Gill A. Recommendations on the use of micro-hydro power in rural development. *Journal of International Development* 2000;12:975–83 John Wiley & Sons Ltd.
- [5] *The EU-China Small Hydro Industry Guide*. Chineham: IT Power Ltd, 1999.
- [7] Harvey A et al. *Micro-Hydro Design Manual*. London: IT Publications Ltd, 1993.
- [8] Khennas S, Barnett A. *Best Practices for Sustainable Development of Micro-Hydro in Developing Countries*, ESMAP Technical Paper 006, IBRD, World Bank, 2000.

Oliver Paish is a Senior Engineer with IT Power Ltd, an international energy consultancy firm which specialises in renewable energy engineering. He has 11 years' professional experience in renewable energy, with particular emphasis on (i) the planning, research, design, testing and project management of hydropower systems, especially micro-hydro in developing countries and low-head hydropower in Europe, and (ii) the technical assessment, economics, financing options and market analysis of all renewable energy technologies for rural energy supply.