

**CRASH
SAVERS VR**

Pressure Simulator

Step by Step Building Guide

Table of contents

1.0 - Build the system

1.1 - Material shopping list

1.2 - Tools and materials

1.0.1 - Tools needed

1.0.2 - Materials needed

2.0 - Get the materials ready

3.0 - Build the system

4.0 - Additional information

4.0.1 - Wood diagrams

1.0 - Build the system

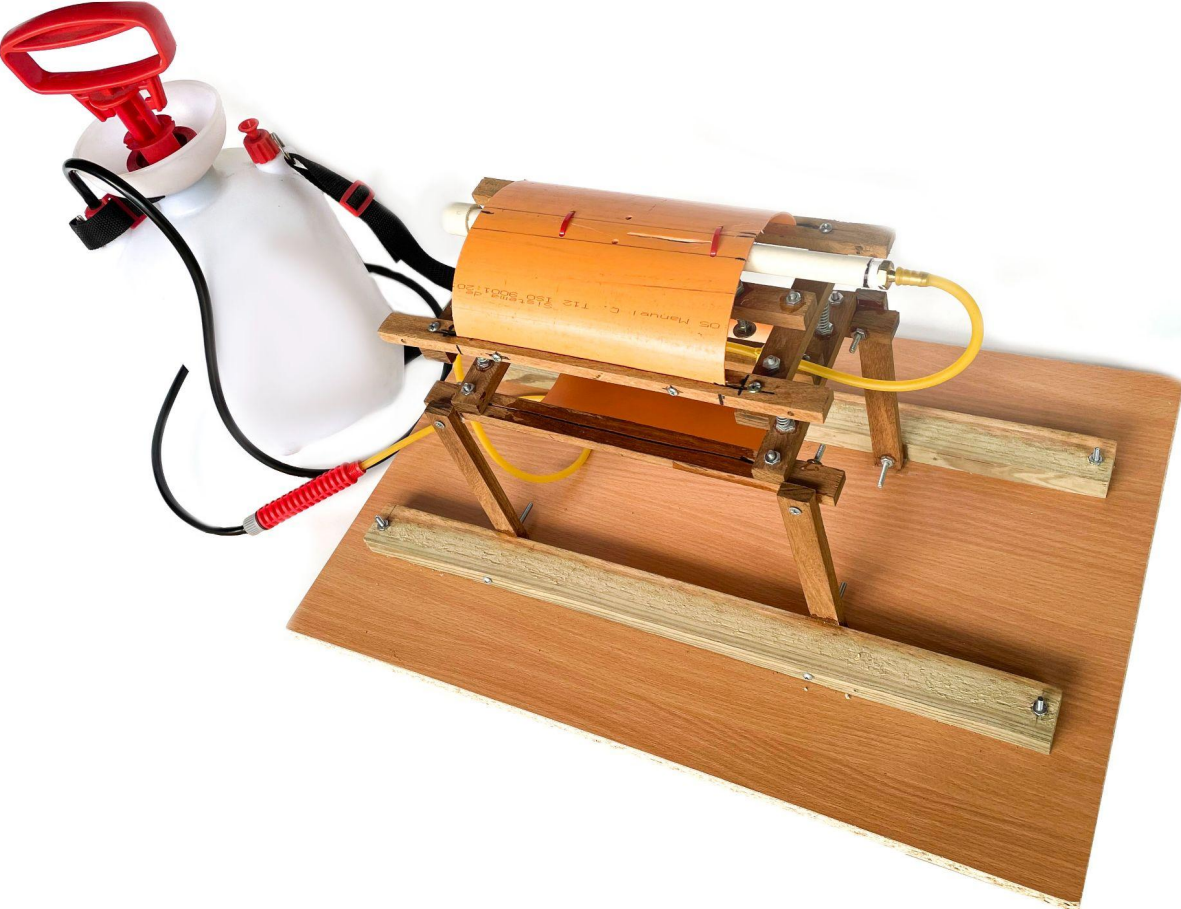

1.1 - Material shopping list

Product	Quantity	Price	Notes
Wood pieces	16	\$5.55	See manual for the different sizes.
Wood slice	1	\$3.20	
PVC pipe (4")	1	\$3.00	
Screws (Diameter 3.0 mm, large 4.5 cm)	16	\$1.60	
Screws (Diameter 3.0 mm, large 8.0 cm)	4	\$0.41	It is recommended to use washers for these screws.
Screws (Diameter 4.0 mm, large 8.0 cm)	3	\$0.31	
Flat head screw (Diameter 3.0 mm, Length 8 cm)	8	\$0.50	
Nut (Diameter 3.0 mm)	36	\$1.85	
Nut (Diameter 4.0 mm)	6	\$0.31	
Spring (Diameter 4.0 mm, large 30 cm)	1	\$3.97	It must be cut in 4 pieces.
Latex plastic hose	2	\$4.00	
Teflon tape	1	\$0.25	
<u>Water pump (Fumigator)</u>	1	\$15.00	
Plastic water bottle	1	\$1.50	
Brass hose fitting adapter, ¼" Barb x ¼" NPT Male Pipe	1	\$7.24	
PVC heat pipe ½"	30 cm	\$0.6	
PVC Plug ½"	1	\$1	
Plastic ties bag (10 units)	1	\$1	
	Total	\$51.29	

1.2 - Tools and materials

In this section you will find a list and description of all the tools and materials needed to build the system. Note that most of the items listed below can be found at home or in your local store.

1.2.1 - Tools needed

The following list shows the tools that are needed to build the system. We strongly suggest for you to gather all the tools before starting to build, this will optimize time and prevent any delay in the process.

Tools list:

Hand saw	400 - grit sandpaper
Drill	Measuring tape
Drill bits (sizes 1/8", 5/8", 5/16")	C-clamp
Philips screwdrivers (various sizes)	Wrenches
Pliers	Rotary tool (Dremel)

Additional notes:

- It is important to note that not all the tools listed below are completely necessary, but if you have access to them, the process will be easier and precise. The tools marked in **green** are the ones that are completely necessary, and the ones marked in **red** are not required, but it will help you get a better result.

1.2.2 - Materials needed

The following list shows all the materials that are needed to build the mechanical system. It is essential for you to get everything listed below before you start building the system.

Materials list:

- PVC pipe 4.00"
- PVC pipe 1/2"

- PVC plug ½”
- Brass hose fitting adapter from PVC to Hose
- Hose (5.00 mm)
- Super glue
- Wood slices

2.0 - Get the materials ready

Code breakdown:

Code breakdown:

To simplify the construction of the simulator each of the parts that are needed to build the simulator have a specific code, this will come handy to identify each different piece when assembling the model.

For the support materials, the code consists of two elements: **type of the piece** and **numbering** corresponding to the group of similar pieces. In the case of screws and springs the code consists of two elements: **type** (screw, nut or spring), and **numbering**. And for the tubes and connections, type (hose, pipe, union or adapter).

Code Letter	Type
W	Wood Piece
S	Screw
FS	Flat head screw
R	Spring
H	Hose
P	Water pump
PVC	PVC tube
U	PVC union
A	PVC adapter

Example 1:

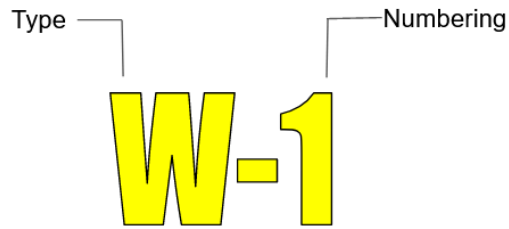

Type	W-wood
Number assigned within a group of similar pieces.	1

Example 2:

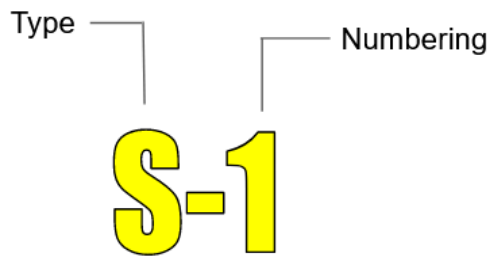

Type	S- Screw
Numbering	1

Example 3:

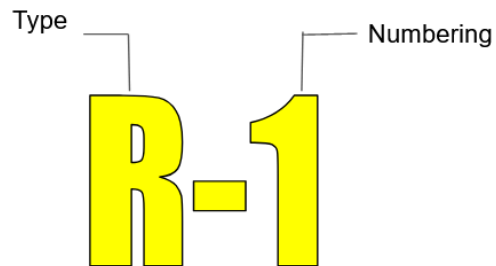

Type	R - Spring
Numbering	1

Example 4:

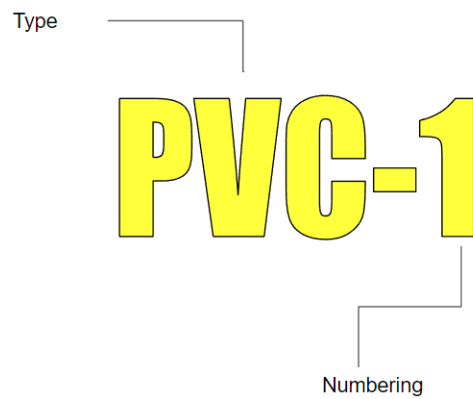

Type	PVC - Pipe
Numbering	1

Materials

Now that you are familiarized with the code of the different pieces and that you have the materials, it is time to get them ready. Below you can find different tables with a list of the pieces needed.

Screws and Springs:

Material	Quantity (units)	Code
Screw (Diameter 3.0 mm, Length 4.5 cm)	16	S-1
Screw (Diameter 3.0 mm, Length 8 cm)	4	S-2
Screw (Diameter 4.0 mm, Length 8 cm)	3	S-3
Flat head screw (Diameter 3.0 mm, Length 8 cm)	8	FS-1
Springs (Diameter 4.0 mm, Length 4 cm)	4	R-1

PVC:

Material	Quantity (units)	Code
Half PVC pipe - 4 in-20 cm	2	PVC-1
PVC pipe - ½ in-30 cm	1	PVC-2
PVC Plug	1	U
PVC Adapter	1	A

Wood pieces list:

Material	Quantity (units)	Code
Wood piece - 30 cm	4	W-1
Wood piece - 15 cm	4	W-2
Wood piece - 24 cm	2	W-3, W-7
Wood piece - 50 cm	2	W-4
Wood piece - 17 cm	4	W-5
Wood slice - 60 x 40 cm	1	W-6

Additional notes:

- If you have access to an internet connection follow this url or type it in your browser.
 - URL: <https://bit.ly/CS21-WOODDIA-ENG>
- If you don't have access to an internet connection, you can find a copy of the document with the diagrams at the end of this manual.

3.0 - Build the system

Following up you can find a set of images that show in detail the step by step process to build the mechanism.

Step 1

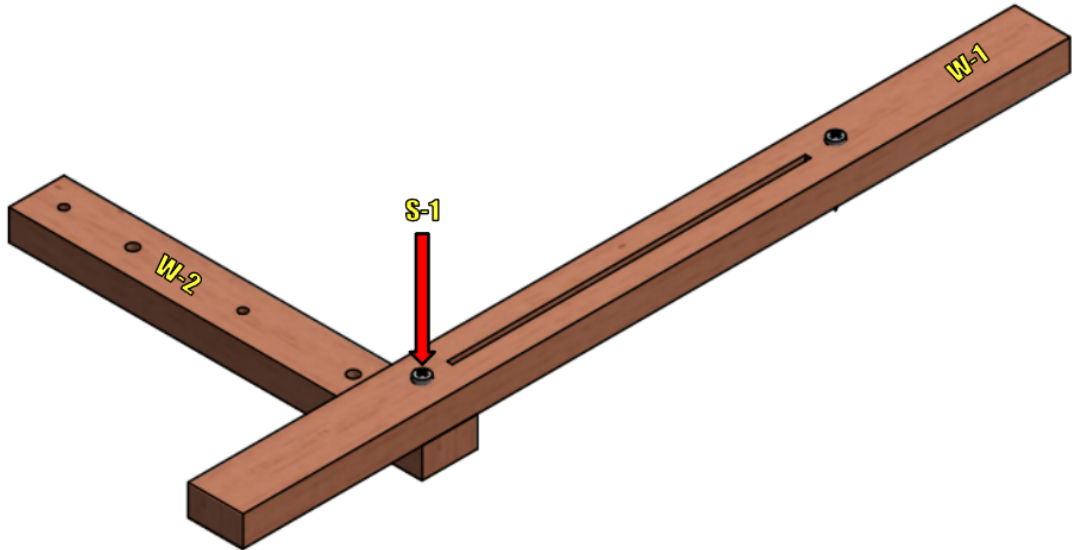

Step 2

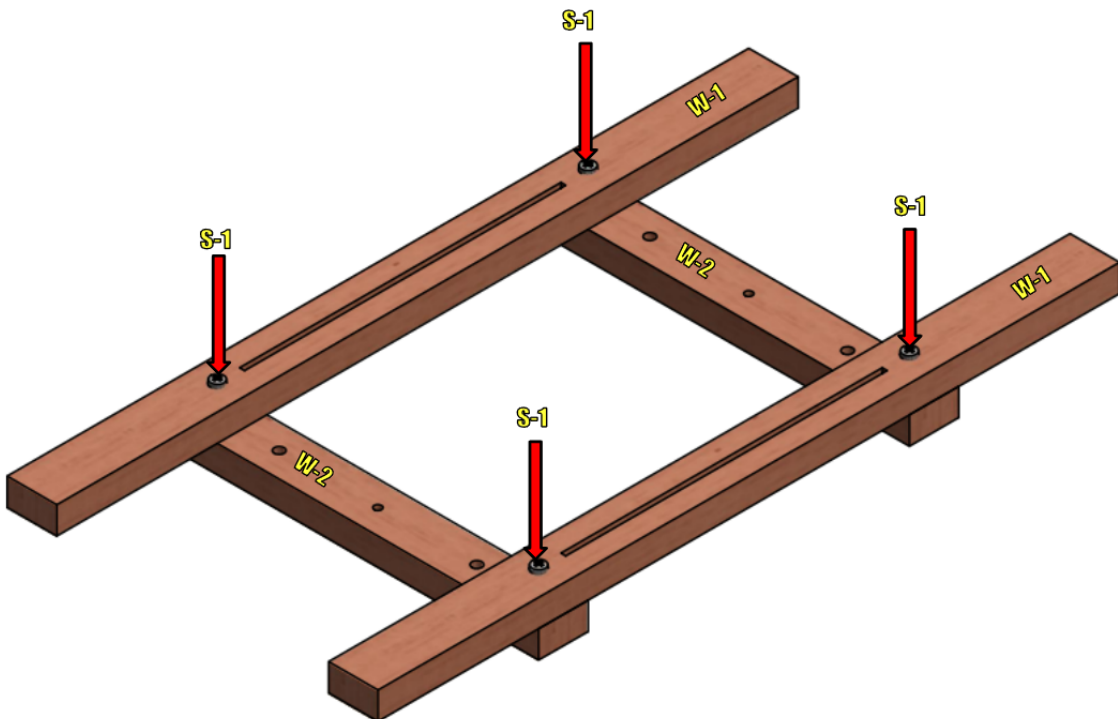

Step 3

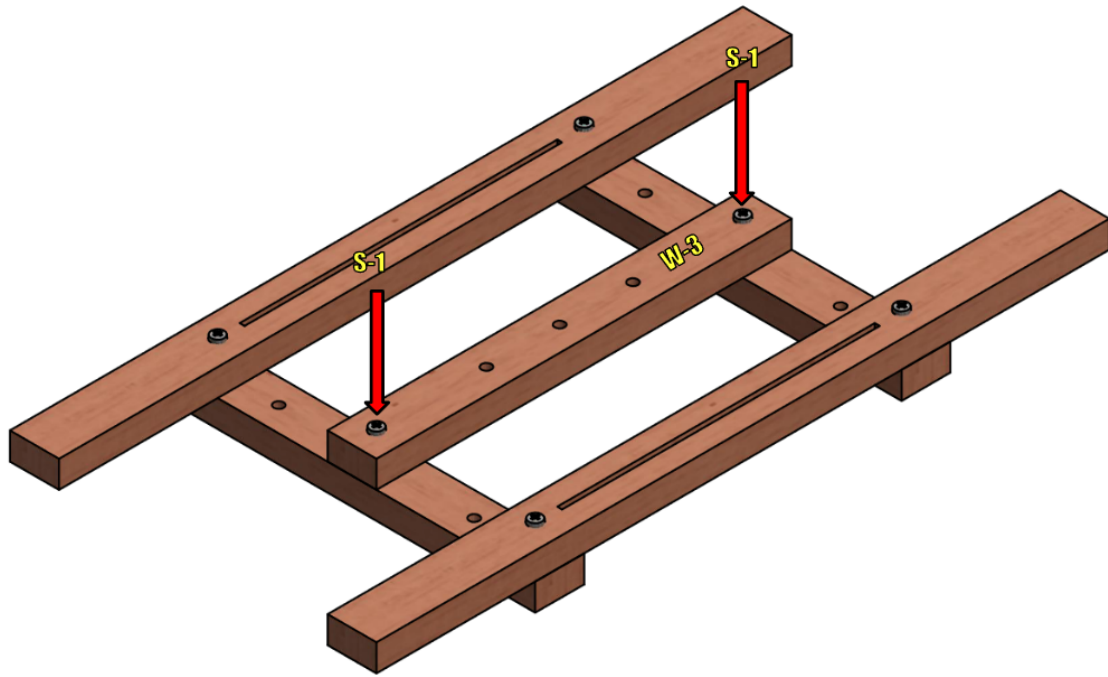

Step 4

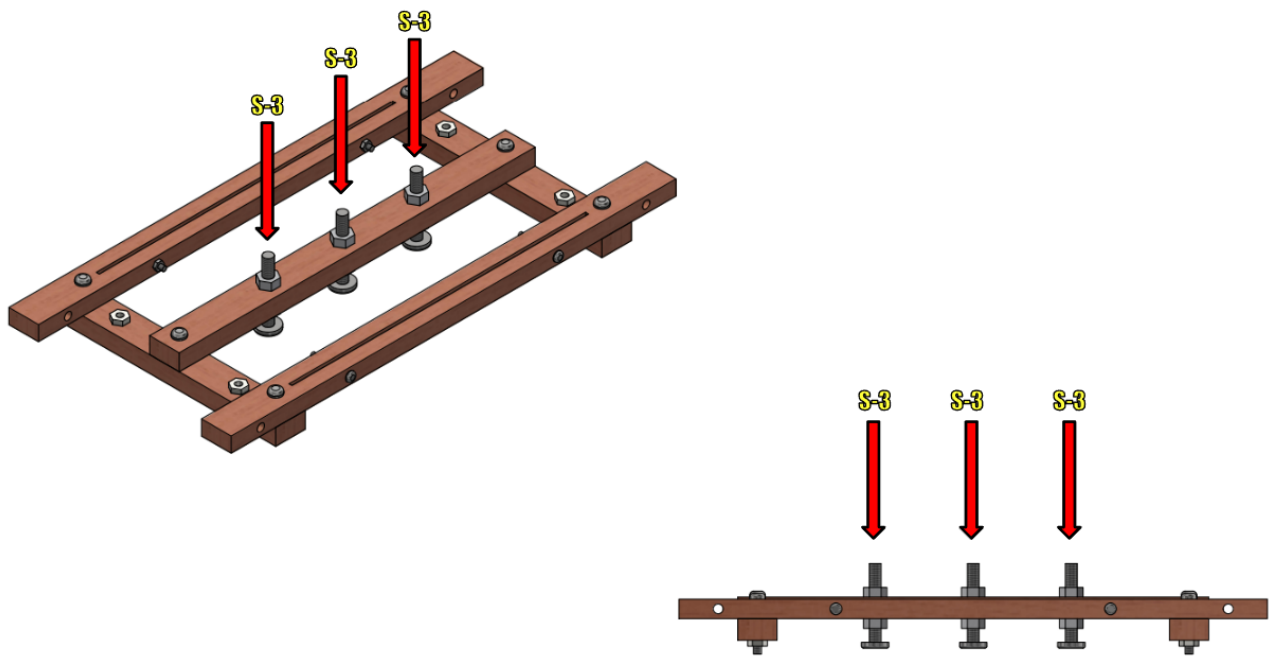

Step 5

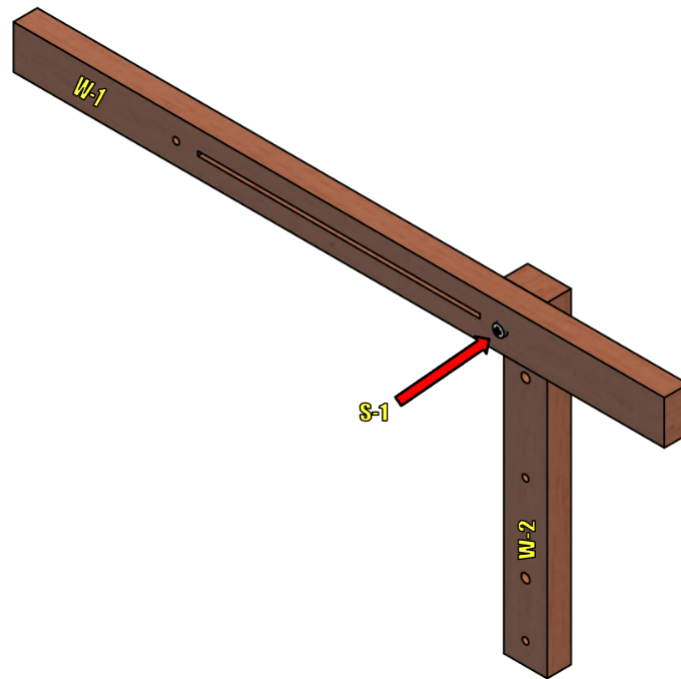

Step 6

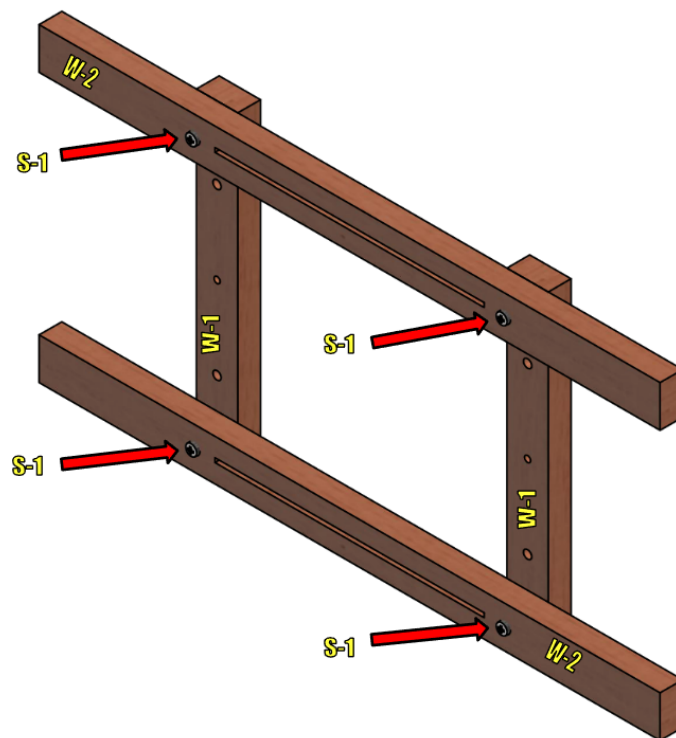

Step 7

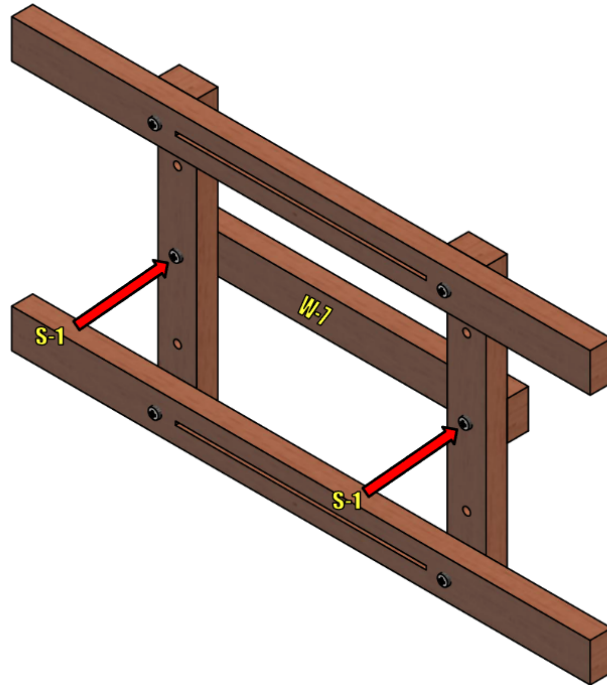

Step 8

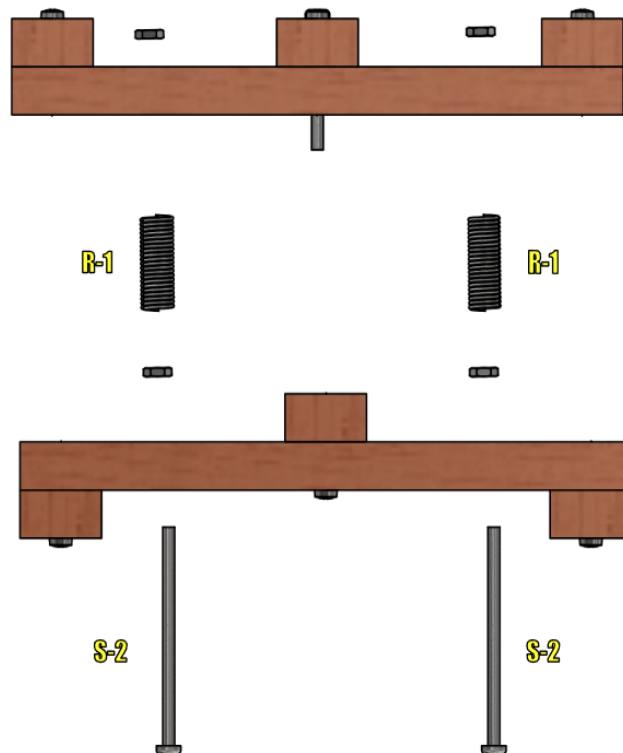

Step 9

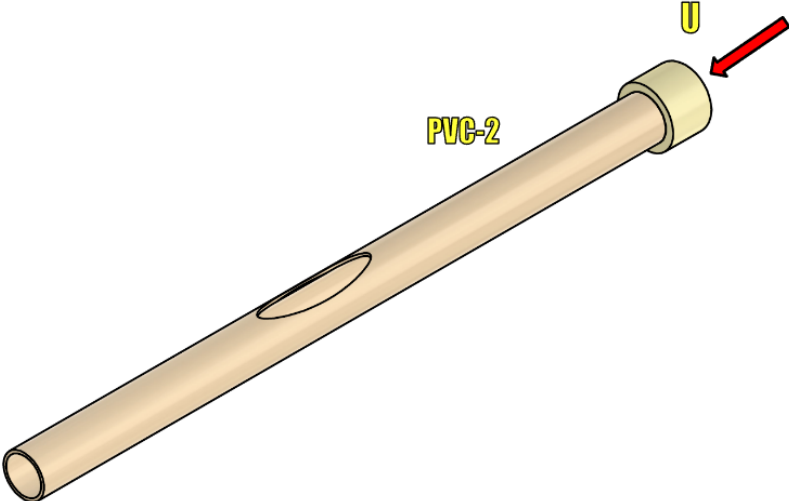

Step 10

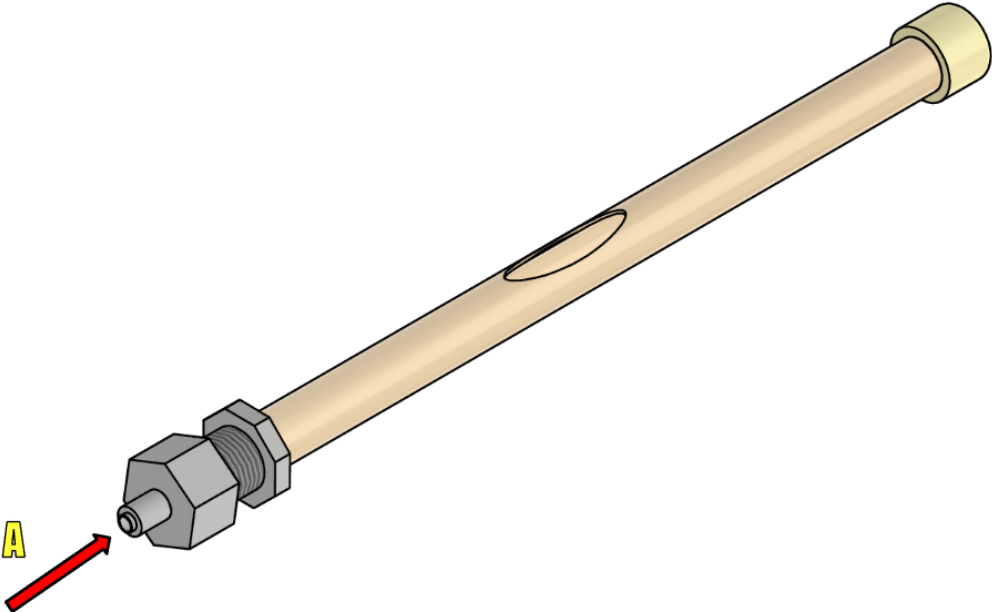

Step 11

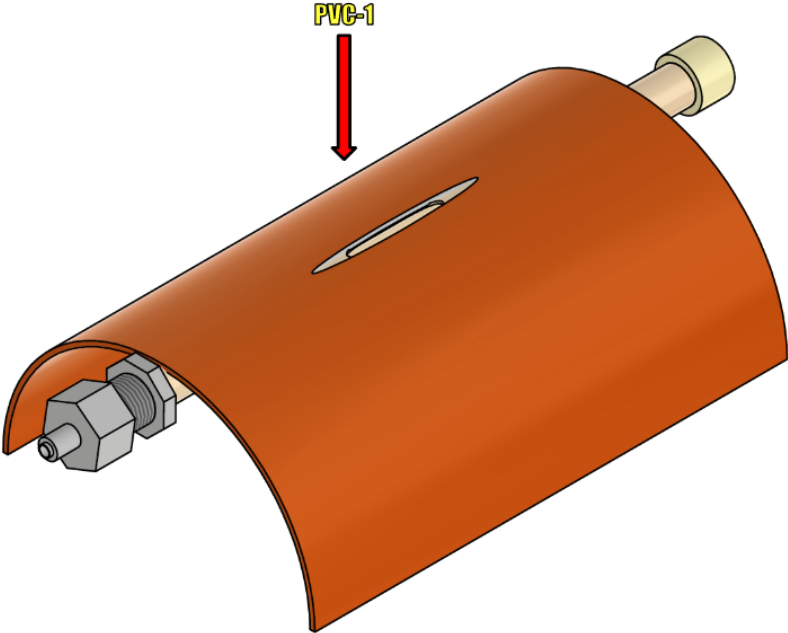

Step 12

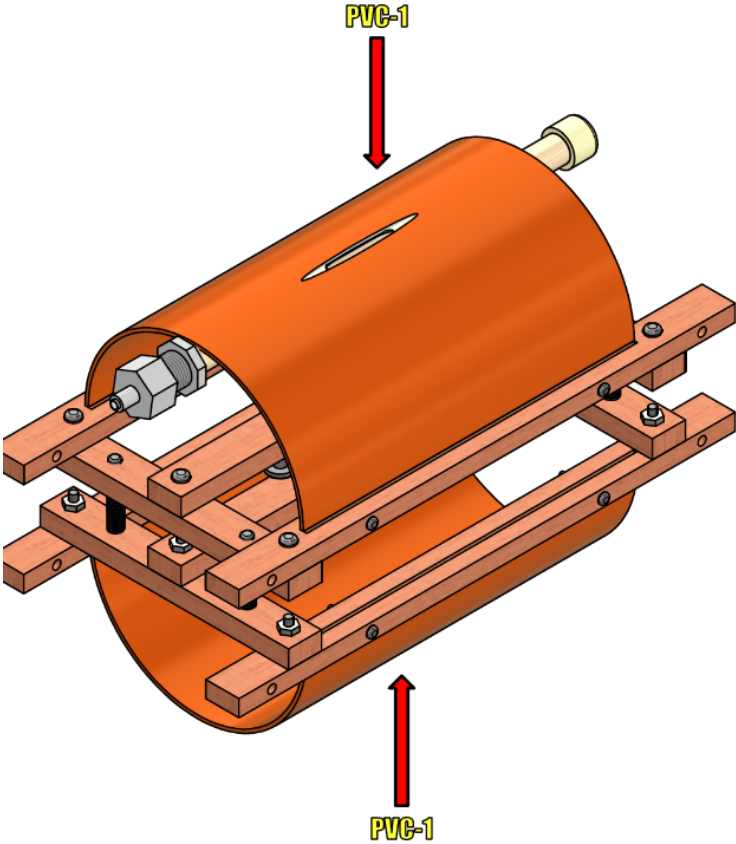

Step 13

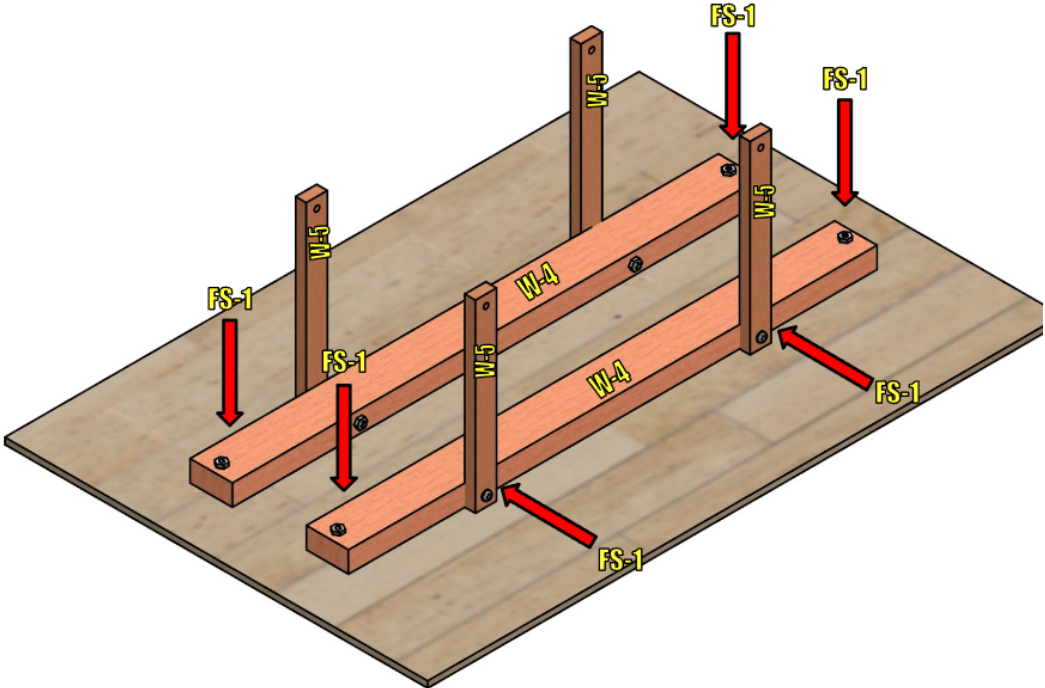

Step 14

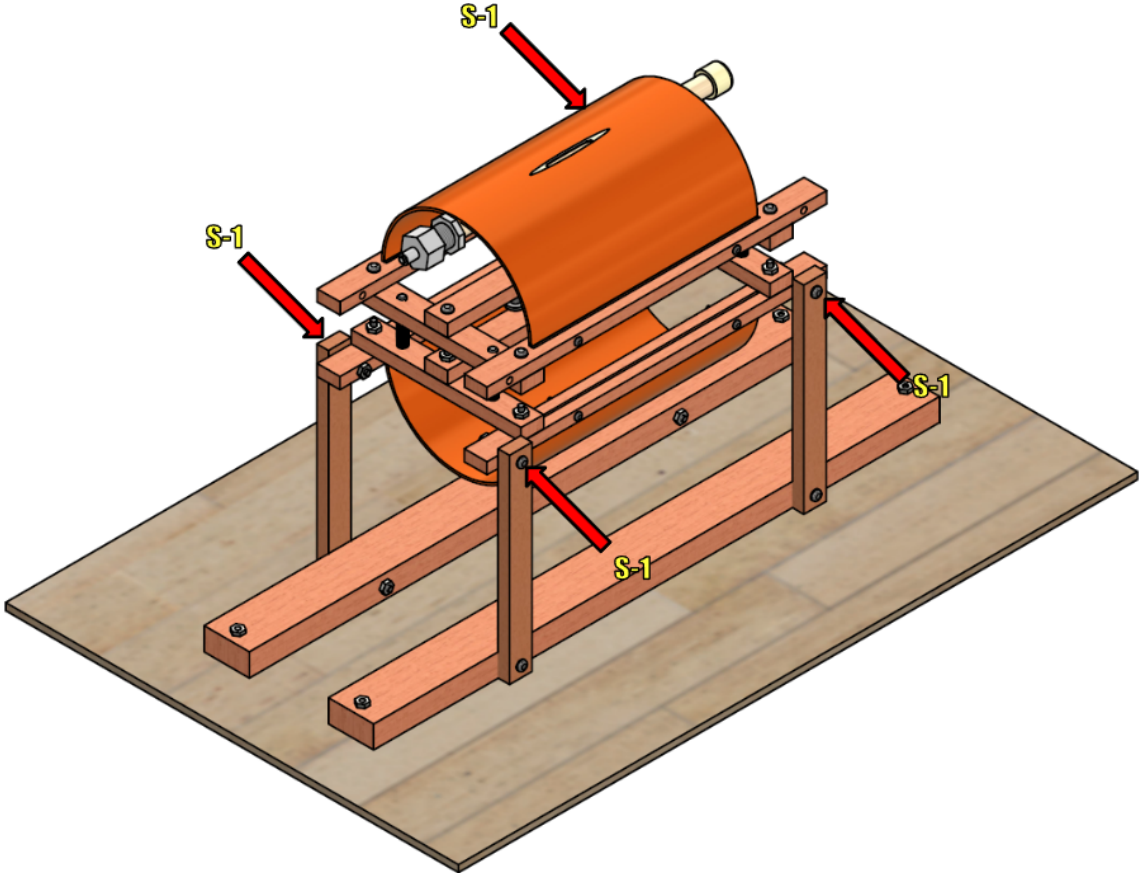

Step 15

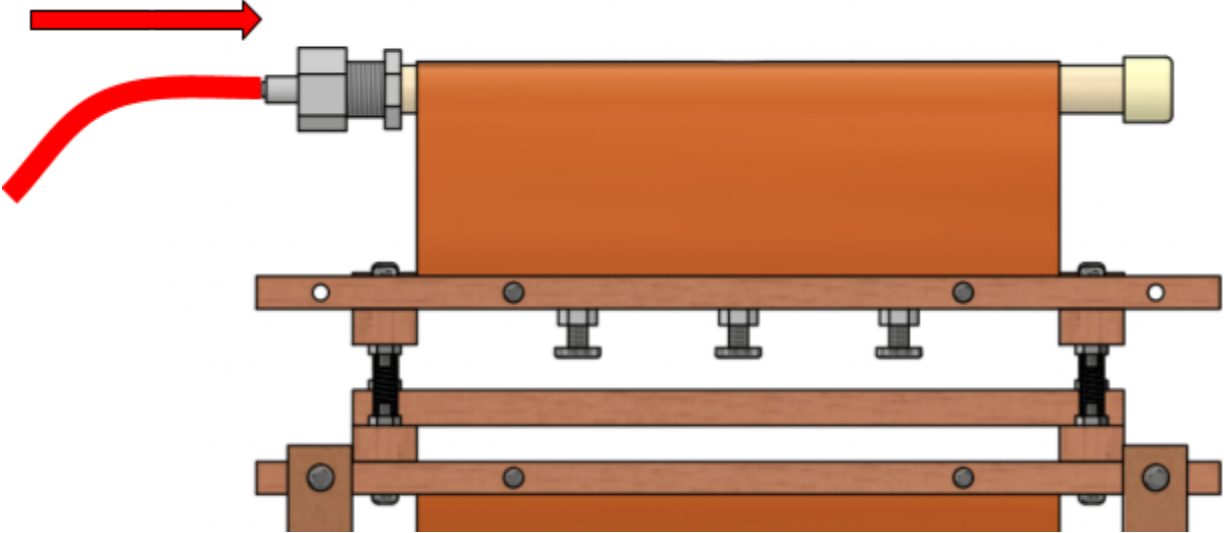

Step 16

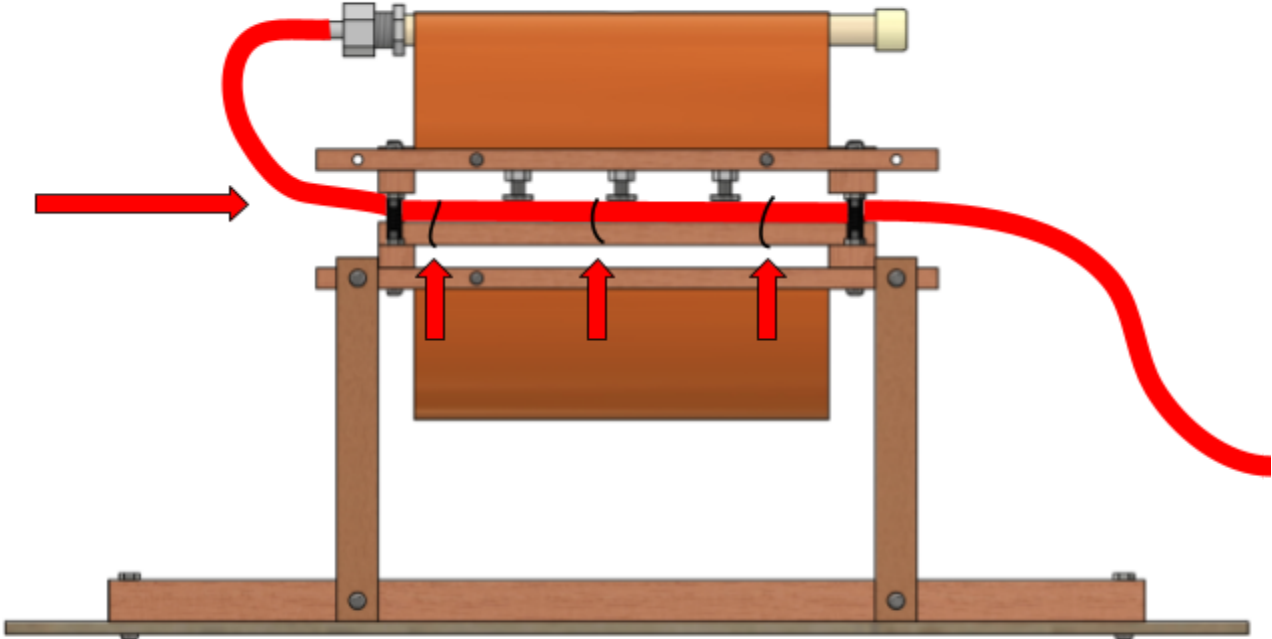

Step 17

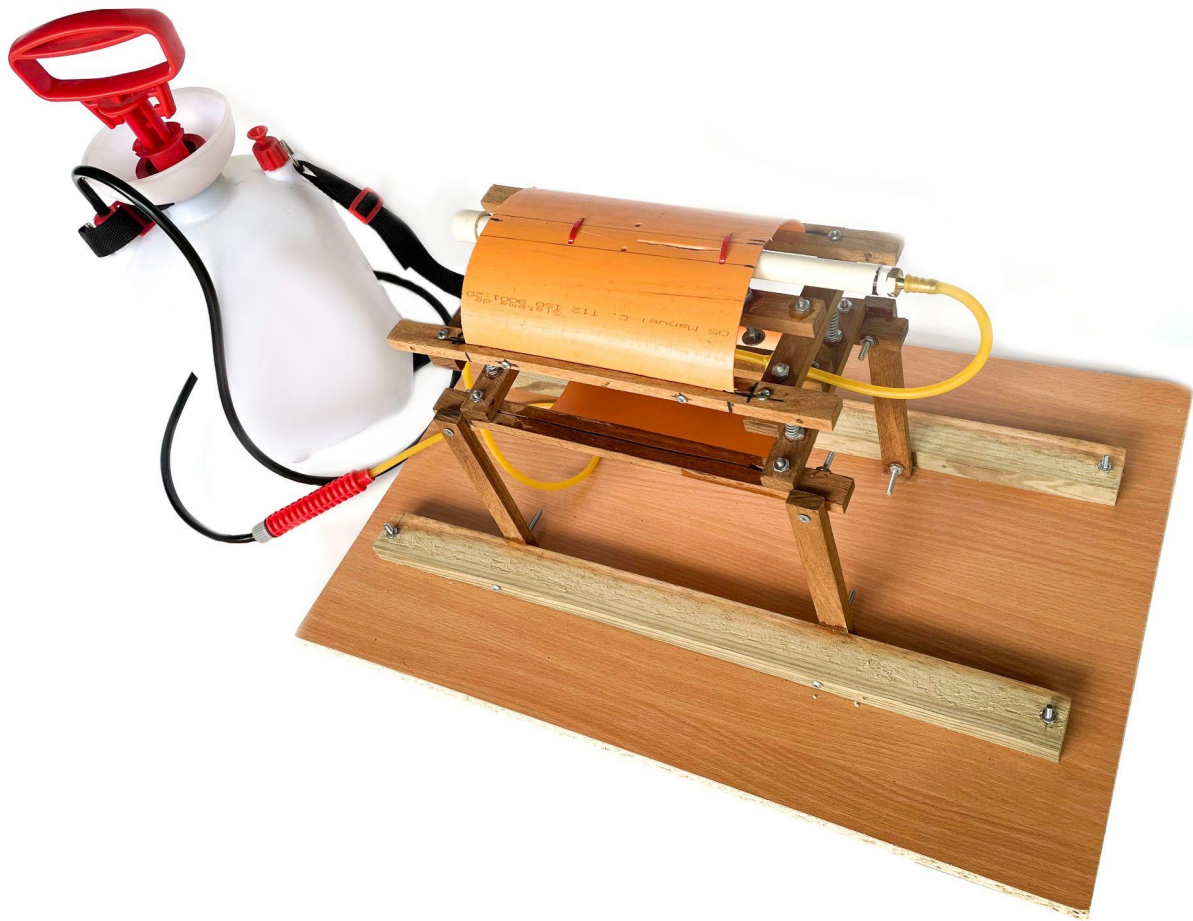
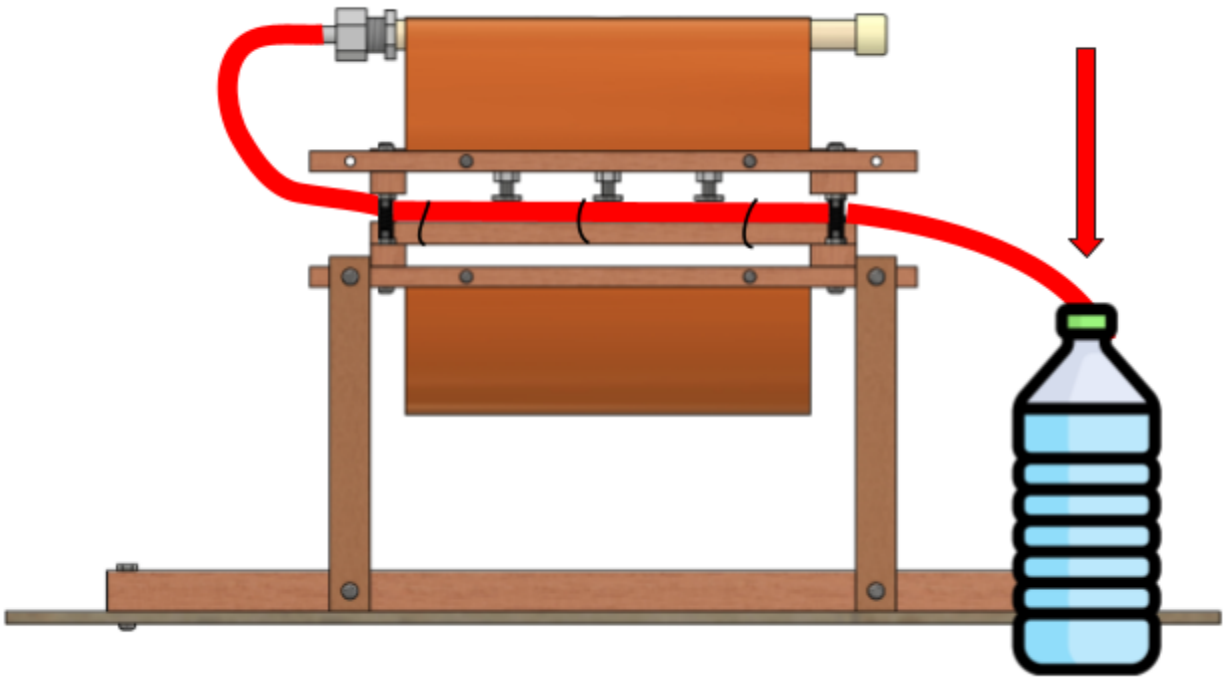

4.0 - Additional information

4.0.1 - Wood diagrams

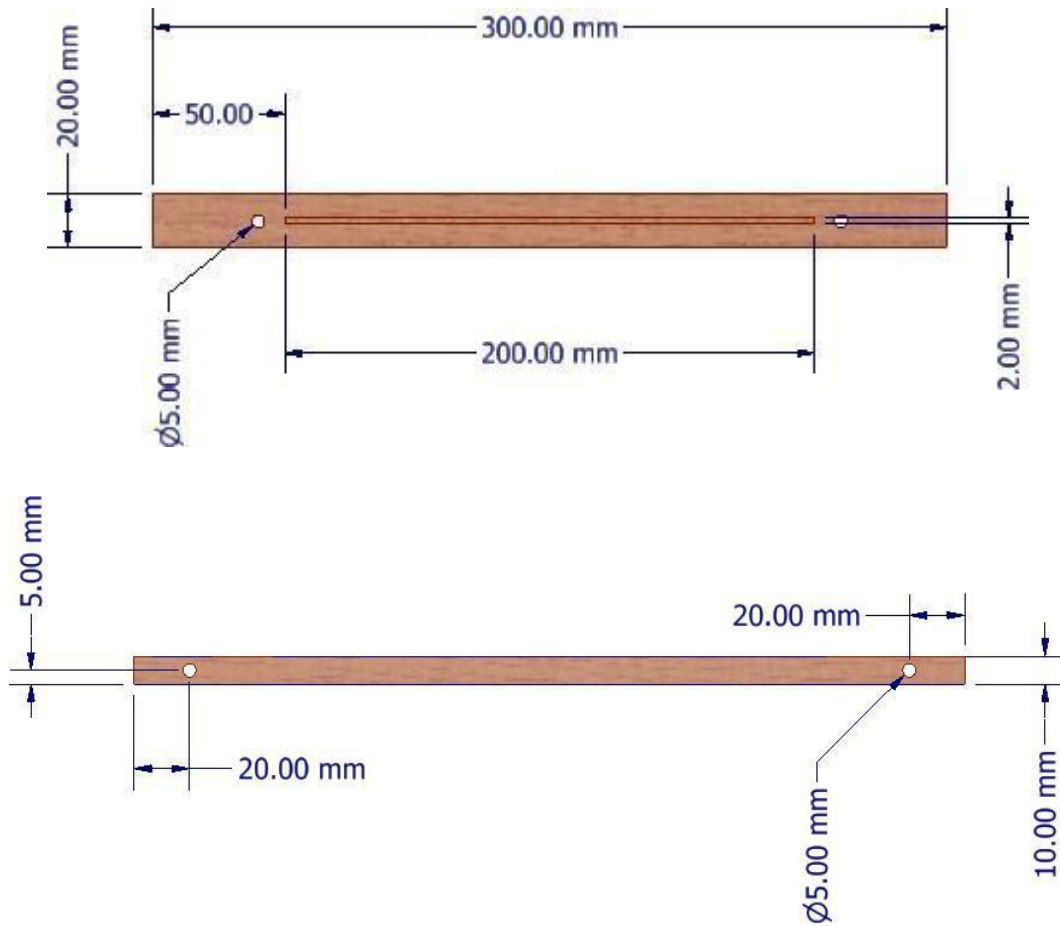

***Note: The thickness is 10mm**

Material	Quantity (units)	Code
Wood piece - 30 cm	4	W-1

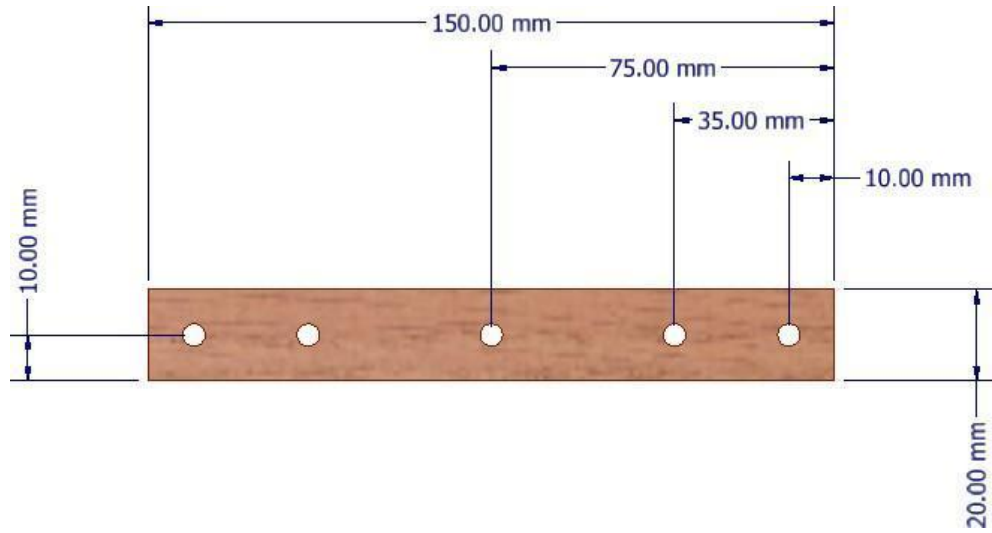

***Note: The thickness is 10mm**

Material	Quantity (units)	Code
Wood piece - 15 cm	4	W-2

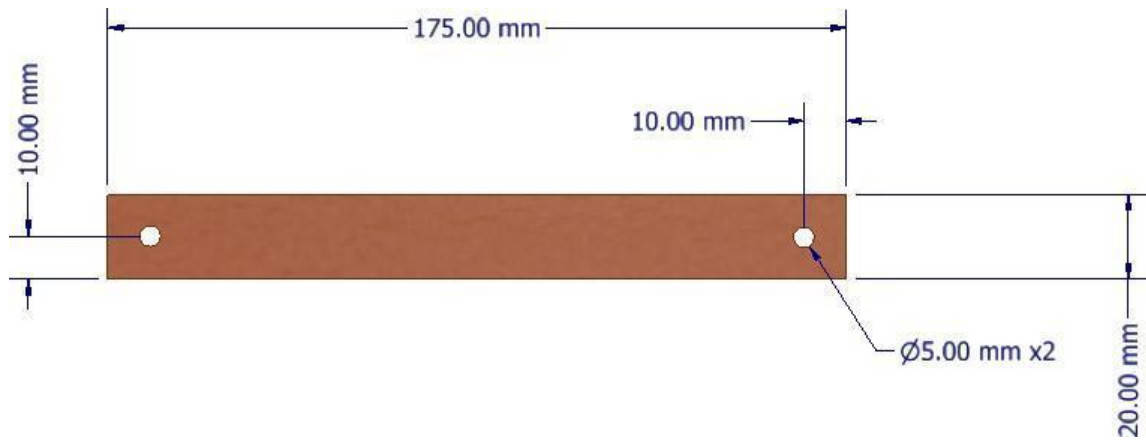

***Note: The thickness is 10mm**

Material	Quantity (units)	Code
Wood piece - 17 cm	4	W-5

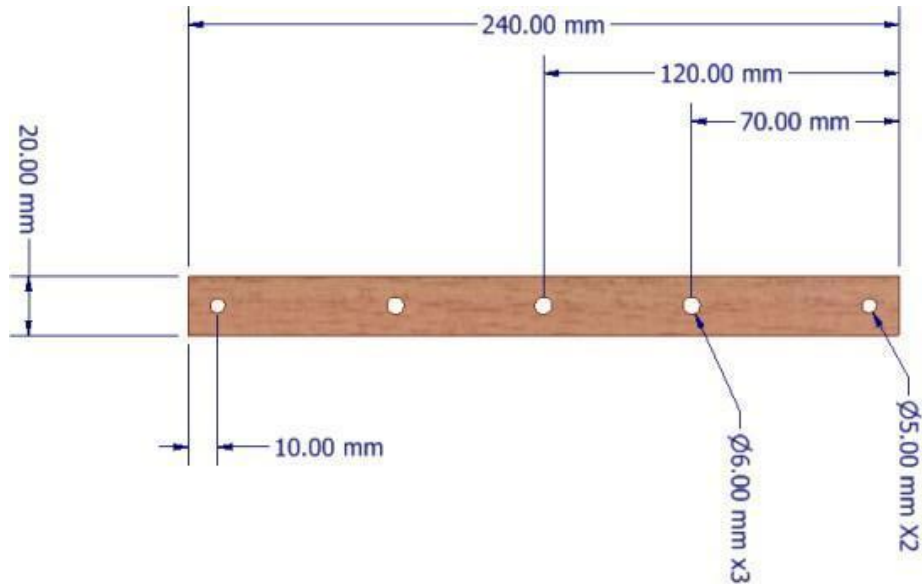

***Note: The thickness is 10mm**

Material	Quantity (units)	Code
Wood piece - 24 cm	1	W-3



***Note: The thickness is 10mm**

Material	Quantity (units)	Code
Wood piece - 24 cm	1	W-7

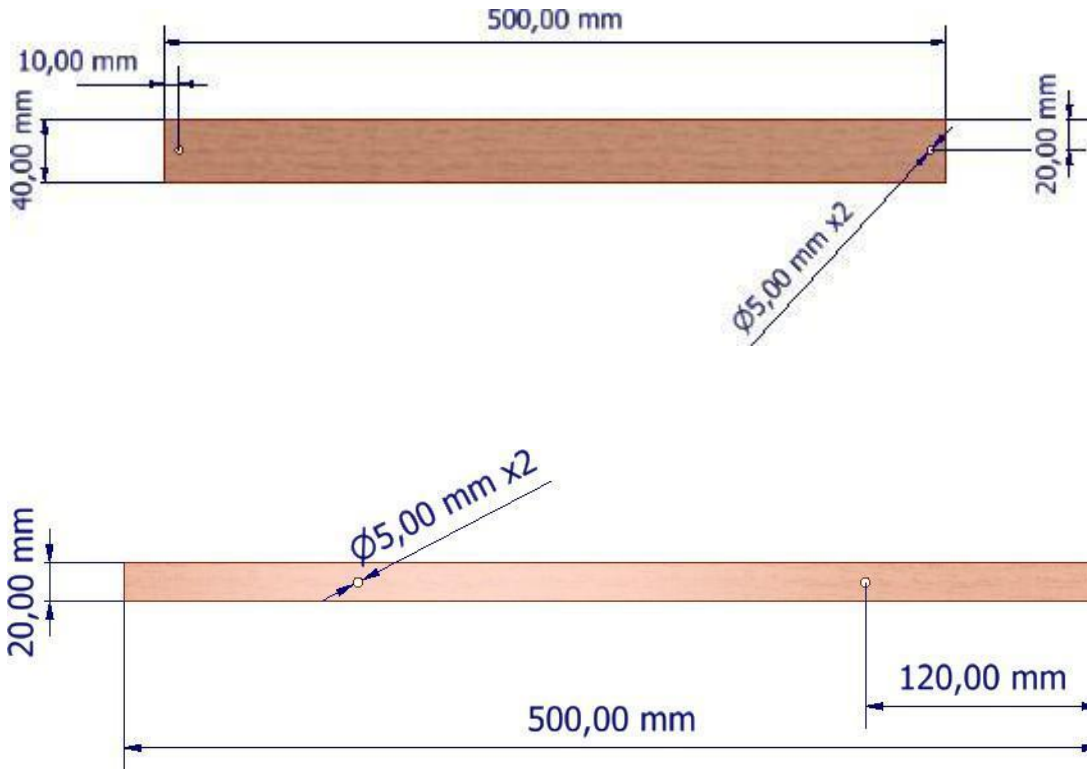

***Note: The thickness is 10mm**

Material	Quantity (units)	Code
Wood piece - 50 cm	2	W-4



***Note: The thickness is 10mm**

Material	Quantity (units)	Code
Wood slice - 60 x 40 cm	1	W-6