

Don't Just Scrap It

Designed by:

Dominick Triola/ Jacob Burns/ Samuel Gunnerson

Humboldt State University

Engineering 215 Spring 2013

Designed for:

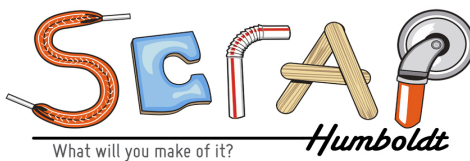



## Table of Contents

Table of Figures .....	vii
Table of Tables .....	viii
1 Problem Formation .....	9
1.1 Introduction .....	9
1.2 Objective.....	9
1.3 Black Box Model.....	9
2 Problem Analysis and Literature Review .....	10
2.1 Introduction to the Problem Analysis .....	10
2.2 Criteria.....	10
2.3 Specifications .....	11
2.4 Considerations .....	11
2.5 Usage .....	11
2.6 Production Volume .....	11
2.7 Introduction to Literature Review.....	11
2.8 Client information.....	11
2.8.1 SCRAP.....	11
2.9 3-ring binders.....	12
2.9.1 Types of Binders .....	13
2.9.2 Poly Binders .....	13
2.9.3 Vinyl Binders .....	13
2.9.4 Cardboard .....	14
2.9.5 Polyvinyl Chloride.....	14
2.10 Do-It-Yourself (DIY) projects .....	14

2.10.1 Homemade umbrellas ..... 15

2.10.2 Accessory holder ..... 15

2.10.3 Bird feeder ..... 15

2.11 Audience to consider..... 15

2.11.1 Teachers ..... 15

2.11.2 Students ..... 15

2.11.3 “Average” people..... 16

2.11.4 Artists..... 16

2.12 Bat Houses..... 16

2.12.1 Bat House Specs..... 17

2.12.2 Bat Species ..... 17

2.13 Nest Boxes ..... 17

2.13.1 Birds to Consider ..... 17

2.13.2 Habitat Requirements For Select Bird Species ..... 18

2.13.3 Construction Considerations..... 19

2.13.4 Other Considerations..... 20

2.13.5 Dimensions Chart ..... 21

2.14 Tote Bags ..... 21

2.14.1 History ..... 21

2.14.2 Concerns ..... 21

2.15 Climate for Humboldt County ..... 22

2.15.1 1.3.1 Rainfall..... 22

2.16 Past Projects ..... 22

2.16.1 Wall Hanger ..... 22

2.16.2 Knife Holder ..... 23

3 Alternatives Analysis ..... 24

3.1 Introduction ..... 24

3.2 Brainstorming ..... 24

3.3 Alternatives ..... 24

    3.3.1 I Can Make That Board Game ..... 24

    3.3.2 All Book No Hands ..... 25

    3.3.3 Umbrella Hat ..... 26

    3.3.4 Binder Building Dice ..... 27

    3.3.5 Wheat Paste Furniture..... 28

    3.3.6 Replaceable Countertop Veneer for Checkout Desk..... 28

    3.3.7 Binder Bird/Bat House..... 29

    3.3.8 Binder Bird Feeder ..... 30

4 Final Decision ..... 31

    4.1 Introduction ..... 31

    4.2 Criteria..... 31

    4.3 Alternative Solutions..... 32

    4.4 Decision Process..... 32

    4.5 Final Decision..... 33

5 Specification of Solution..... 33

    5.1 Introduction ..... 33

    5.2 Solution Description ..... 33

        5.2.1 Creating the Stand ..... 34

        5.2.2 Attaching the Book ..... 35

        5.2.3 Book Light with on/off Switch ..... 35

    5.3 Cost Analysis ..... 36

        5.3.1 Design Cost ..... 36

        5.3.2 Implementation Cost..... 37

5.3.3 Maintenance Cost ..... 38

5.4 Instructions for Implementation and Use of Model ..... 38

5.4.1 Book holder construction instructions..... 38

5.4.2 Instructions for Use ..... 43

5.4.3 Maintenance ..... **Error! Bookmark not defined.**

5.5 Results ..... 43

6 Appendix..... 44

7 Works Cited ..... 47

## Table of Figures

Figure 1: Black Box Model shows the current state of the world and the future state of the world once the solution (the black box) is created. .... 9

Figure 2: Comparison of round ring Vs Angle-D rings (Binders inc. 2013) ..... 13

Figure 3: A series of vinyl binders (NSC international) ..... 14

Figure 4: Wooden Bat House (CWF 2013) ..... 16

Figure 5: Model Bat House temp. Vs. time graph (Jordahl 2013) ..... 17

Figure 6: Rainfall and climate ranges for Eureka (Redwoods.info) ..... 22

Figure 7: Sketch drawn by Samuel Gunnerson outlines process for making a board game out of binders. Cut out one of the binder's panel as the gaming board. Use the sharpie/marker to design the board for whatever game is desired and the remaining binder or binders can be used with the sharpie/marker and the scissors to cut out and design pieces for whatever game is desired. A=Binder with spine removed. B=Black sharpie/marker. C=Left/right handed scissors. .... 25

Figure 8: Sketch drawn by Samuel Gunnerson displays the basic process for constructing the All Book No Hands device. The binder is cut down the center and on parallel sides to be used as flaps to hold up the binder. The spine is taped to the center flap for structural integrity and duct tape is used to secure the spine in place. A= Binder without spine. B= Binder spine. C= Duct tape. .... 26

Figure 9: Sketch drawn by Samuel Gunnerson displays basic process for constructing the Umbrella Hat. The wiring is taped on the inside of the cone formed by the duct tape and binder cut outs. They are then taped to the outside of the headband. A= Cardboard cutouts to form cone. B= Umbrella wiring for structure of hat. C= Headband. D= Duct tape. .... 27

Figure 10: A sketch drawn by Dominick Triola showing the basic 2 dimensional layout for the binder blocks. The three consecutive circles represent binder rings. The double line on the edge of binder folds indicates a separation of two binder halves. .... 28

Figure 11: A sketch drawn by Dominick Triola shows the basic structure of a wheat paste table. .. 28

Figure 12: Sketch drawn by Dominick Triola shows basic layout of a binder countertop veneer with rings on sides of desk. .... 29

Figure 13: A sample of two separate designs drawn by Jacob Burns. The bigger of the two is an example of a modern bat house with roost rods in the interior. The smaller picture is a sample of a traditional bird house. .... 30

Figure 14: A simple picture drawn by Jacob Burns that shows how the bird feeders can be secured and hung from a tree. There are two sets of binder spines so that one can be taken down for maintenance and re-rolled with more feed. .... 31

Figure 15: Back of Book Stand ..... 34

Figure 16: Front of Book Stand ..... 35

Figure 17: Book Light with switch removed ..... 35

Figure 18: Total Design Hours on the All Book No Hands ..... 36

Figure 19: Shows correct binder orientation with wood book seat. .... 41

Figure 20: Taping the slits ..... 41

Figure 21: Fastening skewers to back of front panel. .... 42

Figure 22: Locations of base panel holes. .... 42

Figure 23: Unstructured Brainstorm. .... 44

Figure 24: Unstructured Brainstorm ..... 45

Figure 25: Structured brainstorm using expanding bubbles..... 46

**Table of Tables**

Table 1: Criteria chart .....10  
Table 2: Shows the Delphi chart comparison for each alternative solution..... 32  
Table 3: Cost of Materials for the All Book No Hands ..... 37

# 1 Problem Formation

## 1.1 Introduction

This section outlines our objective and Black Box Model (figure 1.1) for the project. The project will be designed for SCRAP (School Community Reuse Action Program) Humboldt. SCRAP Humboldt is an organized creative reuse center that finds ways to reuse and add value to common trash items so that those items become more than just trash.

## 1.2 Objective

The objective of this project is to take old binders out of the waste stream by creating a way to reuse them that a wide audience can replicate.

## 1.3 Black Box Model

Figure 1.1 shows the current state of the world and the state of the world after the project. The Black Box represents the solution to the problem.



**Figure 1: Black Box Model shows the current state of the world and the future state of the world once the solution (the black box) is created.**

## 2 Problem Analysis and Literature Review

### 2.1 Introduction to the Problem Analysis

The problem analysis is meant to give an understanding of the factors included in the design of our binder project which were followed throughout the design process. These factors include: specifications, considerations, criteria, usage, and production volume.

### 2.2 Criteria

Table 1 is used to determine the overall effectiveness of the finished project as well as provide a basis for guidelines.

**Table 1: Criteria chart**

<b>Criteria</b>	<b>Constraint</b>	<b>Weight (1-10)</b>
Cost	Under budget	6
Environmental Impact	Only non-toxic materials	5
Amount of Recycled Material Used	>50% by weight	8
Recreatable	Must be recreatable at home	7
Aesthetics	Looks trustable. Good enough to spark interest	4
Longevity	Structural integrity of at least six months	6
Number of Binders per Project	Less than or equal to ten	5
<b>Practicality</b>	<b>Legitimately Useful</b>	<b>10</b>

## **2.3 Specifications**

The specifications revolve around our client, SCRAP Humboldt. SCRAP Humboldt is asking to see a creative and innovative redesigning of binders that can be easily understood and recreated. This means creating something that people will find useful or applicable to everyday life. Another specification is overall budget, which is set to around ten dollars.

## **2.4 Considerations**

Considerations are focused primarily around the target audience and consist of a wide spectrum: from elementary school children to the elderly in the Arcata area. This means creating something that people of almost all ages will be able to recreate and have access to.

## **2.5 Usage**

The final product will be an example that SCRAP will use to teach sustainability, environmental responsibility, and the process of up cycling. People who find the product useful or intriguing will be able to easily make replications of the project.

## **2.6 Production Volume**

One or more prototypes will be created for basic understanding of how to construct the product and to gather evidence of effectiveness. More will follow if the project meets or exceeds the constraints and set expectations.

## **2.7 Introduction to Literature Review**

The Literature Review is a collection and summarization of research that will help make informed decisions about the project.

## **2.8 Client information**

### **2.8.1 SCRAP**

Teachers looking to give another life to their once used classroom materials in the Portland Public School system created SCRAP. This eventually led to the development of a small creative reuse center for the community. As its momentum built and popularity increased it sprouted four satellite locations in Texas, California, Michigan, and Maryland (SCRAP History, 2013).



SCRAP is looking to HSU students to help with this cause to reuse what most consider waste. Our specific objective is to up-cycle binders by finding a new and pragmatic purpose for them. Our invention must be re-creatable on a household level and be accessible to a wide audience. The easier it is to make and the more abundant the materials to make it are, the greater likelihood our creation will have of achieving popularity. Our client mentioned previous items that were popular both with and without binders. Without binders included things such as easy to make paper boxes. Binders have been especially popular with teachers in recreating numbers and letters from the vinyl-covered cardboard for classroom use.

## 2.9 3-ring binders

3-ring binders have traditionally been used in the professional and educational areas of work. Types of binders as well as binder materials varies from manufacturer to manufacturer but typically consist of some paperboard for the frame and some metal for the spine and rings. Colors and sizes vary as well (Jagt, Van der, 1988).

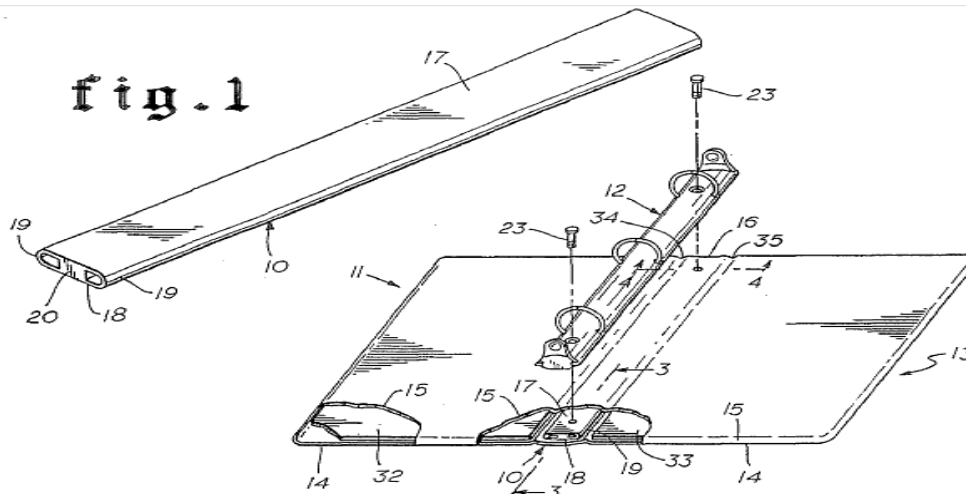

### 2.9.1 Types of Binders

A typical tool for students of academia at any stage is the binder. They are usually made of plastic with a metal spine and three metal rings. The rings can either be in the shape of a smooth circle, or in a shape called Angle-D as shown in figure 2. Binder ring sizes start at 0.5 inches and work their way up to 5 inches. Binders spend most of their lifetime in backpacks until their lifespan is up, which is when the binders end up in the waste stream (Binders inc. 2013).

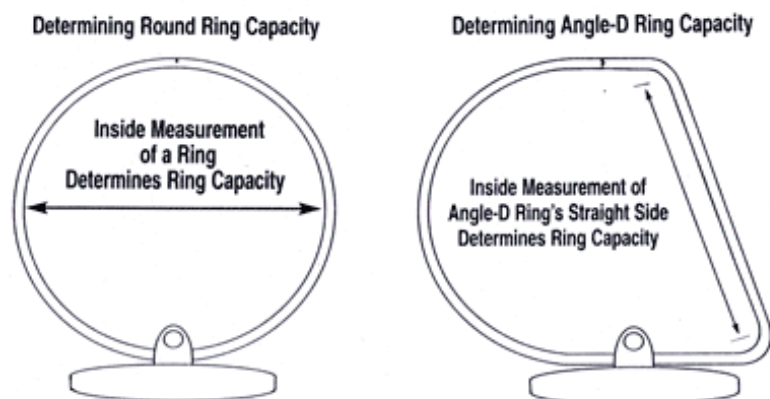

Figure 2: Comparison of round ring Vs Angle-D rings (Binders inc. 2013)

### 2.9.2 Poly Binders

Poly binders are made from a composite plastic material that is flexible, durable, and waterproof. Poly binders tend to be more popular because they have a longer lifespan than vinyl binders and they are also cheaper to manufacture (Binders inc. 2013). These are the typical types of binders found around common households and offices and were the primary focus for use throughout the creation of the product.

### 2.9.3 Vinyl Binders

A binder made from pieces of vinyl bonded around a chipboard skeleton. Vinyl binders are usually of higher quality than poly binders and therefore are more expensive. Vinyl binders are significantly less water proof than poly binders and have a shorter lifespan (Binders inc. 2013).

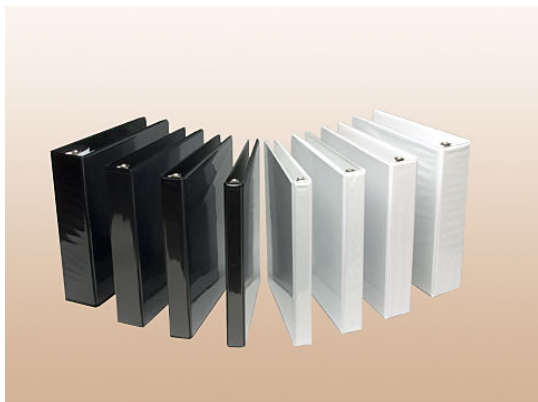

Figure 3: A series of vinyl binders (NSC international)

### **2.9.4 Cardboard**

Cardboard is a main component for all binders and can be found in residential municipal solid waste. It is generally consistent of 44% carbon, 5.9% hydrogen, 44.6% oxygen, 0.3% nitrogen, 0.2% sulfur, and 5% ash (Reinhart, 2004).

### **2.9.5 Polyvinyl Chloride**

Polyvinyl Chloride, which is the plastic used on a majority of binders, is chemically composed of two carbon atoms, three hydrogen atoms, and a chlorine atom to form the molecule. This plastic is toxic but only in direct contact such as inhalation or exposure to the chemical directly through other means that would include groundwater affected by leakage, or evaporation from storage (Vinyl Chloride, 2007).

## **2.10 Do-It-Yourself (DIY) projects**

DIY, or do-it-yourself projects, is a trend for people trying to take care problems without the direct assistance or interaction of some form of an expert or professional. These projects vary as widely as the people who do it themselves.

### **2.10.1     Homemade umbrellas**

These require some sort of plastic bag or tarp, wire clothes hangers, a long pole or branch, duct tape, and scissors. The person then makes the wires into six equal length sizes and begins to form X's with them until they can form a sort of asterisk using the duct tape to secure the wires. The person will then want to secure the pole or branch to the center and then apply the plastic bag or tarp around the edges using the duct tape to seal the edges and any holes (Huang, 2011).

### **2.10.2     Accessory holder**

To make an accessory holder cut off the front and back covers of a binder leaving only the spine with the rings. Attach the spine to any rod within a closet using a staple gun, tape, nails or something else. The rings can then be used to hold a variety of clothing such as ties, belts, and necklaces (Bodeed, 2010).

### **2.10.3     Bird feeder**

To make a bird feeder begin by removing the spine with the rings from the two flaps. Then nail, or by some other means, securely place the spine to the branch of a tree. Then take some pinecones and cover them in suet or peanut butter and roll them in birdseed. Then attach a ribbon or wire to the pinecones and then tie them to the ends of the rings on the spine (Bodeed, 2010).

## **2.11 Audience to consider**

### **2.11.1     Teachers**

Teachers are always looking to do more with less. Being able to assist teachers would appear to be a big target audience. There are always materials to be used and new ways to make sure that no material is wasted within the classroom.

### **2.11.2     Students**

Right behind every teacher is a classroom of students. The most important thing for any teacher is being able to engage the students and if we can make it hands on, easy to learn, and even easier to use then this should aid the overall goal of making our creation popular and attractive.

### 2.11.3 "Average" people

People are looking for more and more ways to spend less while enjoying more. If we can give people something fun to do, that is practical, easy, and adds to their everyday lives then that would mean a major accomplishment for our creation.

### 2.11.4 Artists

Artists generally tend to be at the forefront of being creative. This is exactly what we need and whom we intend to help. Our creation should not only divert waste, be replicable, and serve some value, but should also be innovative. We are not just working with binders, we are trying to change how people look at what they have, and hopefully changing some minds from just throwing it away to giving it another life.

## 2.12 Bat Houses

There are numerous reasons for building bat houses including: pollination, seed-spreading, and insect control. Bat houses can be built out of a variety of waste materials and tend to be quite small in size. Bat houses help preserve certain species of bats like the brown myotis which can eat up to over a thousand insects per hour. Bat houses need to be in direct sunlight at least 7 hours a day, and should mimic the space between the bark of a tree and the trunk (Bat Conservation and Management 2009).

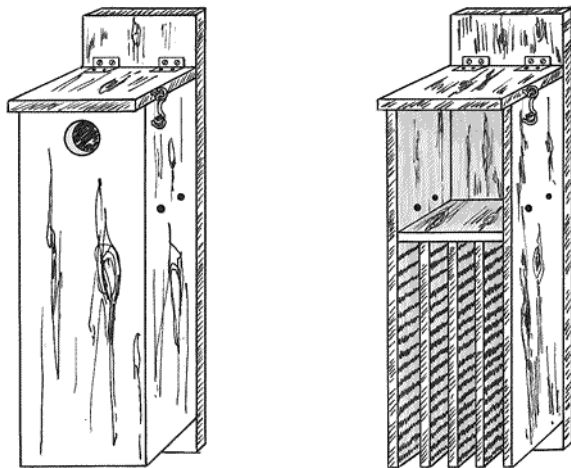

Figure 4: Wooden Bat House (CWF 2013)

### 2.12.1 Bat House Specs

For a bat house to be successful, it should mimic what is found in nature. Bat houses should have chambers at least 20 inches tall and 14 inches wide. Metal wires should be avoided when making bat houses for they can damage the bats. Pressured wood is also not recommended in the making of bat houses because the chemicals in the wood are toxic to bats. The bat house should be dry and should shelter from drafts while maintaining at least 7 hours of direct sunlight in the morning (Bat Conservation International 2004).

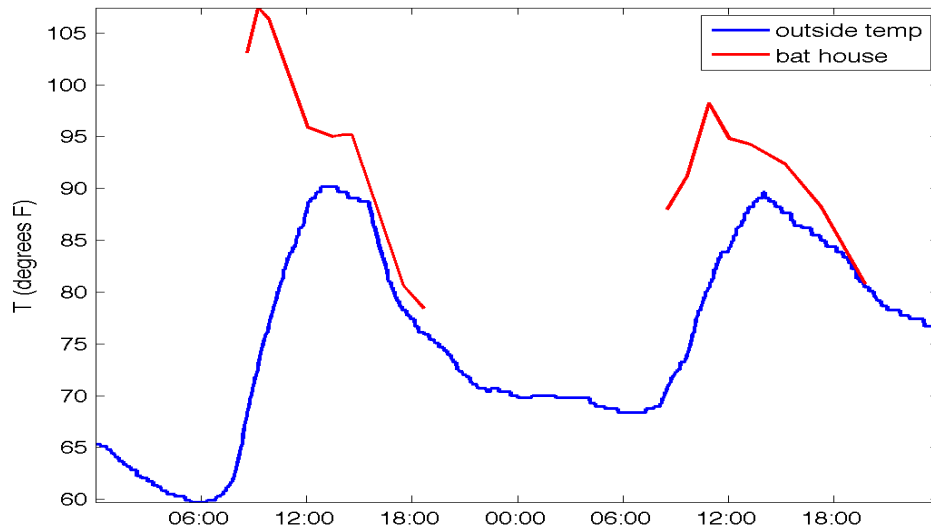

Figure 5: Model Bat House temp. Vs. time graph (Jordahl 2013)

### 2.12.2 Bat Species

Although there are a variety of bats in California, there are a few species that are extremely important to insect control. The most common bat found in California is the little brown myotis and is often found with the Mexican free-tailed bat, the California myotis, and the western pipstrelle. The little brown myotis travels in colonies with numbers in the thousands, and tend to build their nurseries in the summer around buildings and other structures (Falcon Services 2013).

## 2.13 Nest Boxes

### 2.13.1 Birds to Consider

There are many different types of birds that will occupy nest boxes. This is a list of some potential candidates to build boxes for in Humboldt: American Kestrel, Ash-throated Flycatcher, Barn owl, Chestnut-backed Chickadee, screech owls, European Starling, House Sparrow, House

Wren, Northern Flicker, Purple Martin, Tree Swallow, Violet-green Swallow, Western Bluebird, and the White-breasted Nuthatch (Cornell 2013).

### **2.13.2 Habitat Requirements For Select Bird Species**

**Chestnut-backed Chickadee:** Coniferous or mixed coniferous-deciduous forests, near streams, forest edges, or burned areas. Entrance to the nest box should not face prevailing wind. House should be 5-15' above the ground with a 1 1/8" round hole. Boxes must be at least 160' apart from each other, and birds prefer 1" of wood shavings on the bottom.

**Screech Owl:** Forests, forest edges, stream edges within woodlands. They prefer their boxes to be under tree limbs with 2-3" of wood shavings. The boxes must be placed 10-30' high with a 3" round hole that faces north. Each box must be at least 100' apart for Eastern Screech Owls and 1000' apart for Western Screech owls.

**European Starling:** Will live in urban, suburban, rural, or agricultural areas, but tends to avoid mountainous, dry, or dense wooded areas. European Starlings are an aggressive invasive species, and building nest boxes for them is generally not encouraged. They can fit through a hole with a minimum of 1 9/16" diameter.

**House Sparrow:** Live in similar habitats as starlings. Building nest boxes is also discouraged for House Sparrows, which can fit through a 1 1/2" diameter hole.

**House Wren:** Backyards, forest, forest edges, parks, shrub lands. Nest boxes should be placed 5-10' above the ground with a 1 1/4" hole and at least 50' apart from each other.

**Western Bluebird:** Open areas like fields, lawns, and rural spaces with low ground cover, orchards, and forest edges. Entrance should ideally face east or north towards an open field. Boxes should be placed 3-6' above ground, have an entrance hole with 1 1/2" diameter, and be at least 300' apart from each other (Cornell 2013).

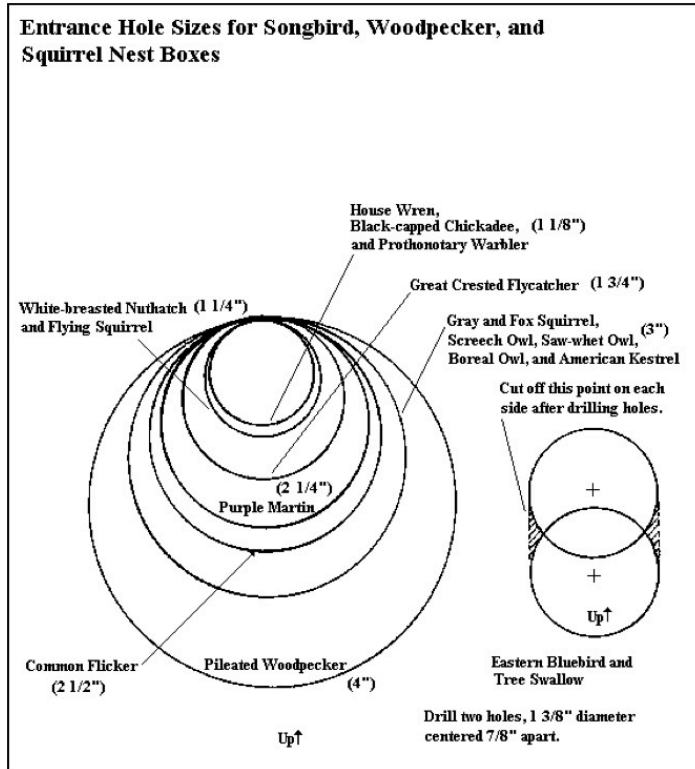

(Cornell 2013)

## 2.13.3 Construction Considerations

### 2.13.3.1 Materials

Wood is considered the best material for nest boxes because of its durability, insulation capabilities, and breathability. 3/4" pine, plywood, bald cypress, or red cedars are considered good woods to use. Water-based exterior latex paint is used to waterproof the wood, but should not be used on the inside of the box, because the fumes are toxic to the birds (Woodworking 2004).

### 2.13.3.2 Ventilation and Drainage

Ventilation and drainage are important for maintaining a balance of heat and moisture in nest boxes. Ventilation can be provided by drilling 1/4" holes in the walls just below the roof, or by leaving a small gap between the walls and the roof. Drilling 1/4" holes in the bottom of the nest box can provide drainage (Woodworking 2004).

### ***2.13.3.3 Predator Prevention***

If nest boxes are made for particularly vulnerable bird species like bluebirds or Purple Martins care must be taken to set up anti-predator guards and maintain nest boxes regularly. A sheet metal guard placed underneath the nest box can protect it from cats, squirrels, opossums, and raccoons. Placing the nest on a metal pole coated with petroleum jelly or cayenne pepper will make it inaccessible to snakes, and lining the roof of the box with soap will detour wasps and bees from nesting in it. If any aggressive pest bird nests are noticed nearby they should be destroyed (Woodworking 2004).

## **2.13.4 Other Considerations**

Nest boxes generally do not do well when placed near feeders.

Grooves on the outside of the entrance hole as well as mesh or grooves below the inside of the hole can provide traction to make entering and leaving the nest box easier for adult and nestling birds. (Woodworking 2004) The material the nest box is made of can affect the reproductive success of the birds and frequency of residence in the nest boxes. This is likely due to factors like maintained temperature within the nest box and attractiveness of the box to potential residents and predators. For example, woodcrete had higher occupation frequency and reproductive success for Tree Sparrows in Spain. Woodcrete provided better protection from predators as well as a 1.5°C higher average temperature than conventional wood boxes (Garcia-Navas et. al 2008).

## 2.13.5 Dimensions Chart

BIRD	floor dimensions		box height		entrance height		entrance diameter		placement height (ft)	
	inches	(mm)	inches	(mm)	inches	(mm)	inches	(mm)	feet	(m)
American Kestrel	6 x 6	152 x 152	14	356	9-12	229-305	3	76	12-20	4-6
American Robin	7 x 8	178 x 203	8-10	203-254	platform				6-15	2-4.5
American Tree Sparrow	10 x 10	254 x 254	15	381	6	152	1½	38	2-3	6-9
Ash-Throated Flycatcher	6 x 6	152 x 152	8-12	203-305	6-10	152-254	1½	38	5-15	1.5-4.5
Barn Swallow	open nester		6	152					8-12	2-6
Barred Owl	10 x 10	254 x 254	15	381	10	254	6	152	10-30	3-9
Bat	no floor		24-30	610-762	bottom		7/8 x 6	22 x 152	10-30	3-9
Black-Capped Chickadee	4 x 4	102 x 102	8-10	203-254	6-8	152-203	1½	29	4-15	1-4.5
Butterfly	7 x 7	178 x 178	24	610	slots up & down front of box		½ x 3	13 x 76	3-5	1-1.5
California Towhee	open nester				platform				4-12	1-6
Eastern Bluebird	5 x 5	127 x 127	8-12	203-305	6-10	152-254	1½	38	4-6	1-2
Eastern Phoebe	open nester		6	152					8-12	2-4
Grey Shrike-Thrush	open nester				platform				10-15	3-4.5
House Finch	6 x 6	152 x 152	6	152	4	102	2	51	8-12	2-4
House Sparrow	10 x 10	254 x 254	15	381	6	152	1½	38	10-20	3-6
House Wren	4 x 4	102 x 102	6-8	152-203	4-6	102-152	1	25	5-10	1.5-3
Japanese White-Eye	open nester				platform				6-10	2-3
Mourning Dove	8 x 8	203 x 203	8-10	203-254	platform		7-15	2-4.5	10-20	3-6
Northern Cardinal	8 x 8	203 x 203	8-10	203-254	platform		5-8	1.5-2	5-8	1.5-2
Northern Flicker	7 x 7	178 x 178	16-18	406-457	14-16	356-406	2½	64	6-20	2-6
Prothonotary Warbler	5 x 5	127 x 127	6	152	4-5	102-127	2	51	4-8	1-2
Purple Martin	6 x 6	152 x 152	6	152	1-2	25-51	2¼	57	6-20	2-6
Pygmy Nuthatch	4 x 4	102 x 102	6-8	152-203	4-6	102-152	1	25	5-10	1.5-3
Red-Breasted Nuthatch	4 x 4	102 x 102	8-10	203-254	6-8	152-203	1¼	32	5-15	1.5-4.5
Red-Headed Woodpecker	6 x 6	152 x 152	12-15	305-381	9-12	229-305	2	51	10-20	3-6
Redwing	5 x 5	127 x 127	6	152	4-5	102-127	2	51	4-8	1-2
Rosella	8 x 8	203 x 203	17-18	432-457	10	254	3	76	17-20	5-6
Treecreeper	3 x 4	76 x 102	10	254	9	229	1¼	32	8-15	2-4.5
Tufted Titmouse	4 x 4	102 x 102	10	254	4-6	102-152	2	51	5-15	1.5-4.5
Violet-Green Swallow	5 x 5	127 x 127	6-8	152-203	4-6	102-152	1½	38	5-15	1.5-4.5
Wood Duck	10 x 18	254 x 457	6-8	152-203	12-16	305-406	4	102	10-20	3-6
Yellow-Bellied Sapsucker	5 x 5	127 x 127	12-15	305-381	9-12	229-305	1½	38	10-20	3-6

(Woodworking 2004)

## 2.14 Tote Bags

### 2.14.1 History

Many governments are beginning to ban plastic grocery bags, because of their negative effect on wildlife and the waste stream. California leads the way in plastic bag regulations. In 2007 San Francisco banned the use of plastic bags in large grocery stores. In 2012 they included all retail stores in the ban, and Los Angeles did the same along with Malibu, Fairfax, and Palo Alto (Klick and Wright 2012).

### 2.14.2 Concerns

Following the ban of plastic bags in San Francisco, Klick and Wright (2012) conducted a study which provided evidence that the use of tote bags caused an increase in foodborne illness and E.

Coli related emergency room visits. This data suggests that it is important for reusable bags to be washable and washed frequently.

## 2.15 Climate for Humboldt County

The temperature along the Coast of Humboldt County varies only by around ten degrees between summer and winter. Highs rarely enter the 80's in summer and rarely fall below 32 degrees Fahrenheit in the winter. Humboldt County is known for its high amounts of rainfall especially during the winter months. However constant and steady temperatures make Humboldt Bay a beacon for migrating birds and other animals (co.Humboldt.ca.us).

### 2.15.1 1.3.1 Rainfall

Rainfall in Humboldt County is usually experienced year-round, even accumulating over 40 inches of rain during the driest season. During the wettest season, rainfall totals can exceed over 100 inches. A lot of the Bays moisture isn't in the form of rain, but rather is in the form of fog that condenses in the redwood forest. Most trees get there constant supply of water from this fog and the constant rain helps support the large trees in the area (co.humboldt.ca.us).

Eureka	HI	LO	AVG	RAIN inches"
JAN	54	42	48	5.8
FEB	56	43	49	5.7
MAR	56	43	50	5.3
APR	57	45	51	3.1
MAY	59	48	53	1.6
JUN	61	50	56	0.5
JUL	63	52	57	0.1
AUG	63	53	58	0.4
SEP	63	51	57	0.9
OCT	61	48	54	2.6
NOV	57	43	50	5.9
DEC	55	42	48	6.1

Figure 6: Rainfall and climate ranges for Eureka (Redwoods.info)

## 2.16 Past Projects

### 2.16.1 Wall Hanger

One way to reuse old binders is to remove the metal rings and screw them to a wall to create a key, kitchen utensil, towel, or bag hanger.

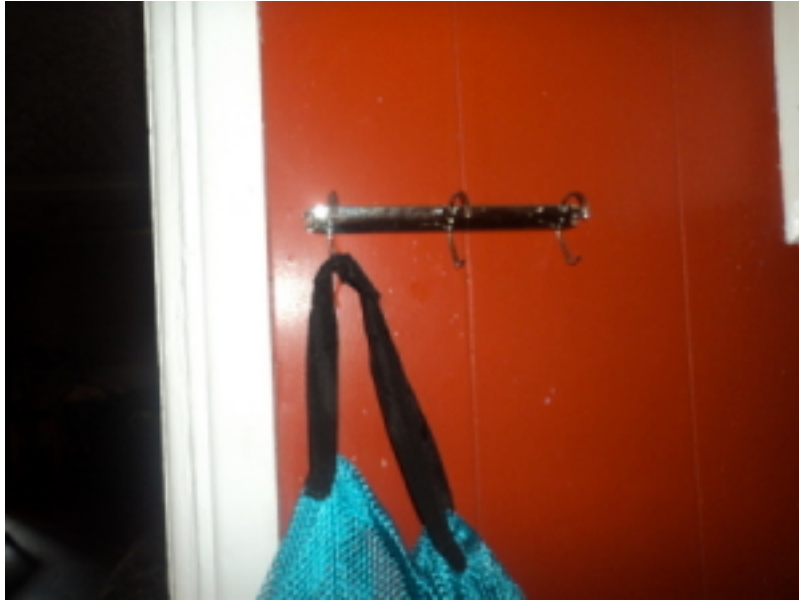

(coville123)

### 2.16.2 Knife Holder

A way to reuse a binder after the metal rings have been removed is to cut slits in the spine of the binder and hang it on a wall, or rack as a knife holder.



(Dansken)

## **3 Alternatives Analysis**

### **3.1 Introduction**

The alternatives analysis section describes the brainstorming process and summarizes each of the alternative projects considered. A sketch is provided for each alternative.

### **3.2 Brainstorming**

Team Don't Just Scrap It conducted several brainstorming sessions as seen in appendix B. Through some creative thinking, we came up with eight solid solutions that we could use with up cycled binders. Since the criteria regarding our group were relatively loose, our separate solutions seemed to spread a wide intellectual spectrum. We tried to focus on ways that our project can be replicated and/or used by many age groups, for we tended to favor the projects that anyone could make. Brainstorming documents can be found in the Appendix section.

### **3.3 Alternatives**

#### **3.3.1 I Can Make That Board Game**

The I Can Make That Board Game is made up of multiple intact binders with the spines removed, a black sharpie or marker, and left or right handed scissors. Remove one of the large panels attached to the center flap of the binder to be used as the board itself. Designs on the board will vary, from an eight by eight-checked board for chess or checkers, to more elaborate designs for games such as scrabble. Multiple other binders will need to be used for pieces or various other items depending upon game. These can include checker pieces, chess pieces, and scrabble pieces. This allows a vast majority of the binder to be used with the exception of the binder's metal spine. This is a straight forward design and process outlined in figure 7 that most parents and/or teachers can perform with their children/students and have something to use even after constructing the I Can Make That Board Game.

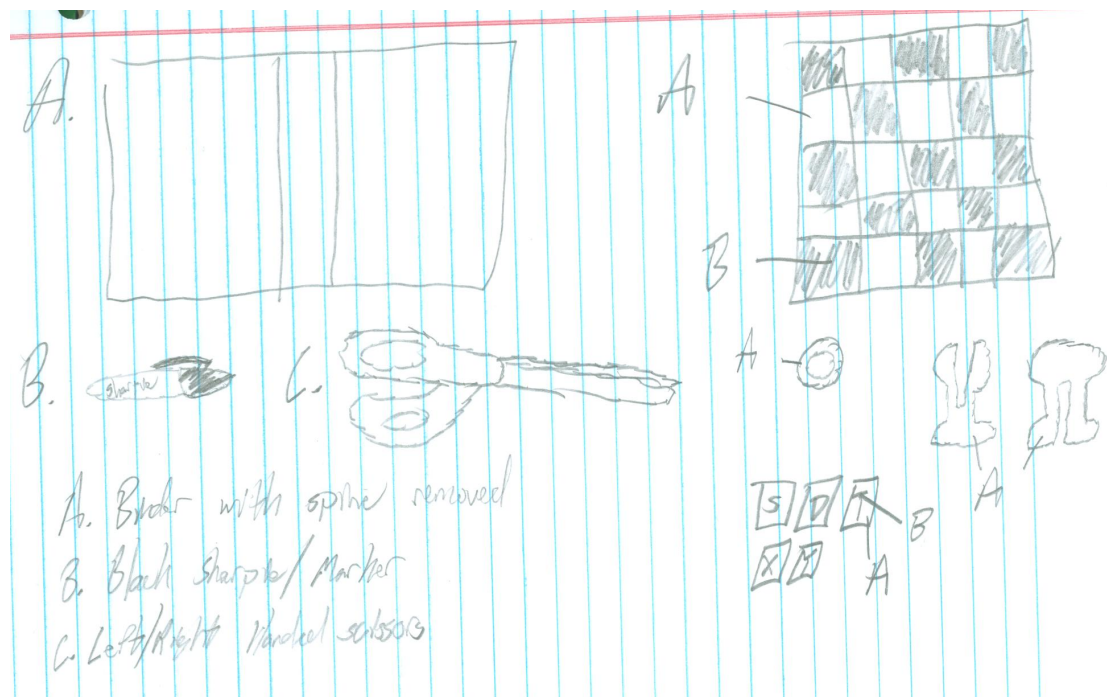

**Figure 7: Sketch drawn by Samuel Gunnerson outlines process for making a board game out of binders. Cut out one of the binder's panel as the gaming board. Use the sharpie/marker to design the board for whatever game is desired and the remaining binder or binders can be used with the sharpie/marker and the scissors to cut out and design pieces for whatever game is desired. A=Binder with spine removed. B=Black sharpie/marker. C=Left/right handed scissors.**

### 3.3.2 All Book No Hands

The All Book No Hands is comprised of one large intact binder with spine and duct tape. The spine is first removed to be used as the support beam. Then the center is cut approximately one third up and two small panels on parallel sides are cut approximately one fourth of the distance up and folded back to allow the binder to lean back. The spine is duct taped to the center panel, the top of binder, and where the rings touch the binder for structural integrity. After this is done small panels can be cut out and pulled forward to be used as holding mechanisms for books. Size, shape, and distance should be determined based upon book dimensions. This design gives a new life to a single binder without anything being wasted. This allows the owner of the All Book No Hands to read a book without having to hold it with a single, or both hands allowing them to freely accomplish some other less mentally straining task with their hands.

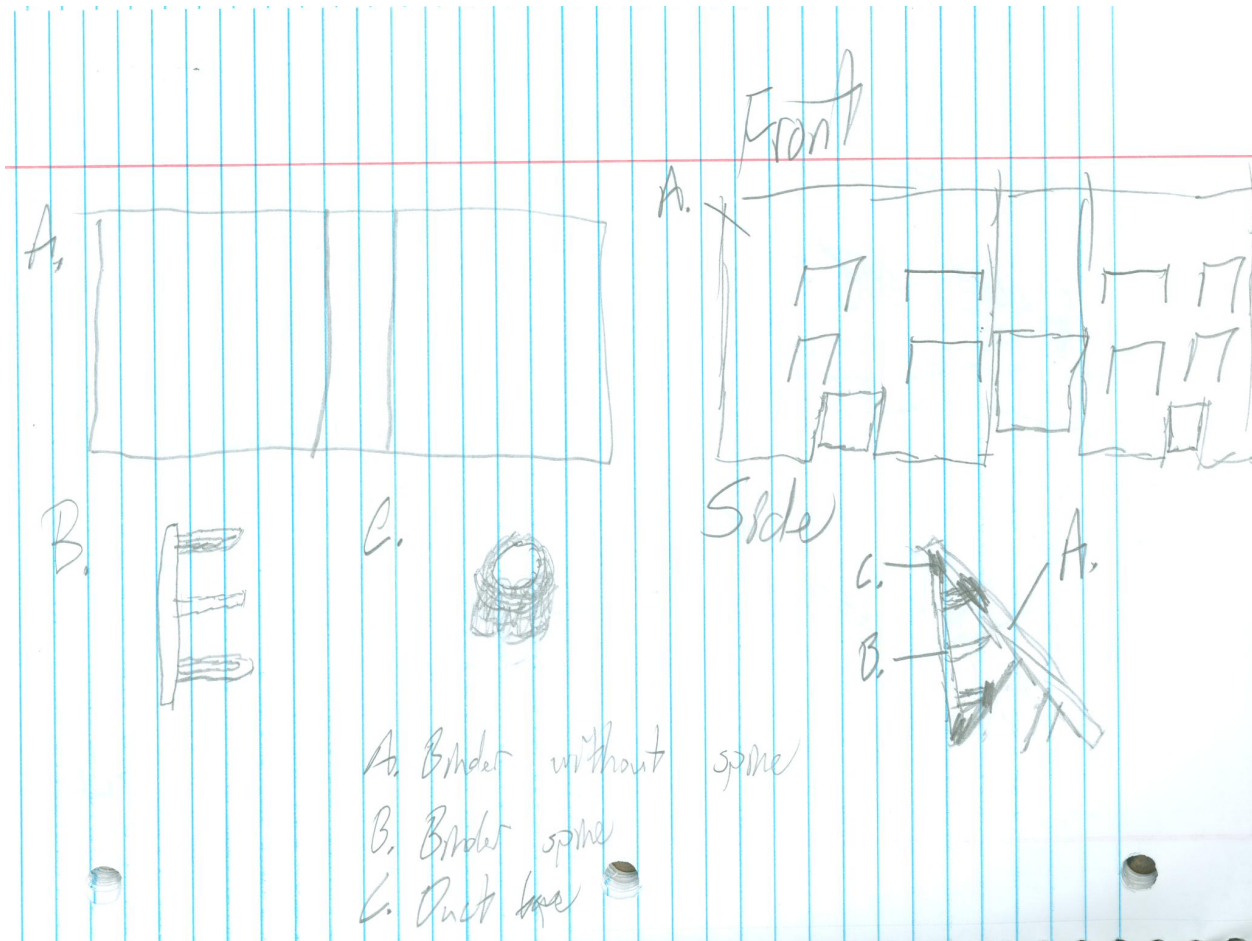

**Figure 8: Sketch drawn by Samuel Gunnerson displays the basic process for constructing the All Book No Hands device. The binder is cut down the center and on parallel sides to be used as flaps to hold up the binder. The spine is taped to the center flap for structural integrity and duct tape is used to secure the spine in place. A= Binder without spine. B= Binder spine. C= Duct tape.**

### 3.3.3 Umbrella Hat

The Umbrella Hat would be made up of up-cycled binders and duct tape along with materials from up-cycled umbrellas as well as headbands. It would be formed by first cutting out equal sized triangles out of the binders to form a cone large enough to surround the body of the person wearing it. These are then duct taped together with the umbrella attached inside with equal spacing throughout. The plastic band is then placed on the outside of the headband and duct taped in place. This design allows the reuse of binders without wasting too much of the materials and a chance to reuse umbrellas with torn and useless fabric. This idea is seen to be specifically useful in the upper hemispheres for the amount of given rain in these locations making the Umbrella Hat a viable option if one does not wish to carry an umbrella or does not have one.

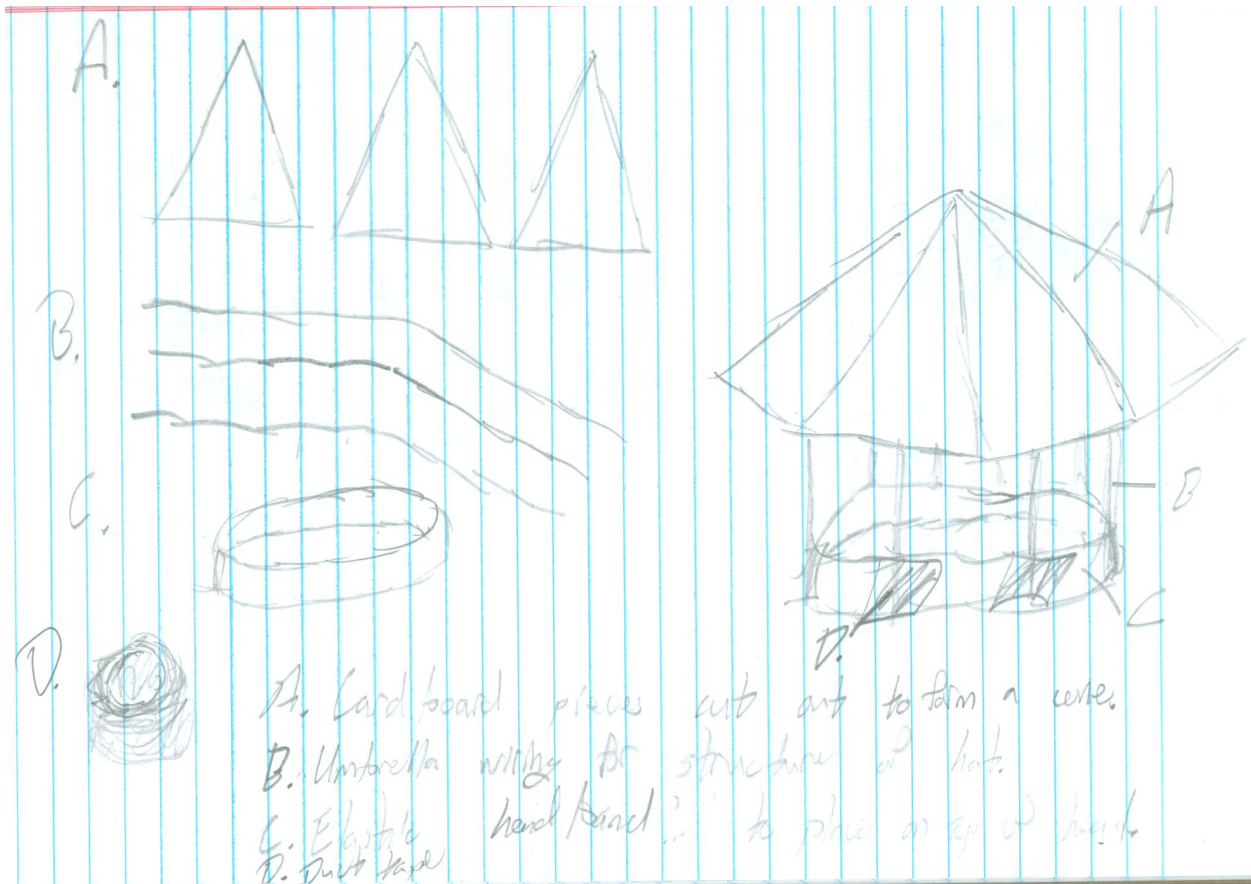

**Figure 9:** Sketch drawn by Samuel Gunnerson displays basic process for constructing the Umbrella Hat. The wiring is taped on the inside of the cone formed by the duct tape and binder cut outs. They are then taped to the outside of the headband. A= Cardboard cutouts to form cone. B= Umbrella wiring for structure of hat. C= Headband. D= Duct tape.

### 3.3.4 Binder Building Dice

The Binder Building Blocks will be constructed using binders and their clips as shown in figure 10. The clips will be moved to the edges of binders so they can clip to the edges of other binders to form a block as seen in figure x. White stickers will be placed on the outside of each panel to create dice. These blocks will serve as creative building and assembly tools while teaching the basics of dice to kids.

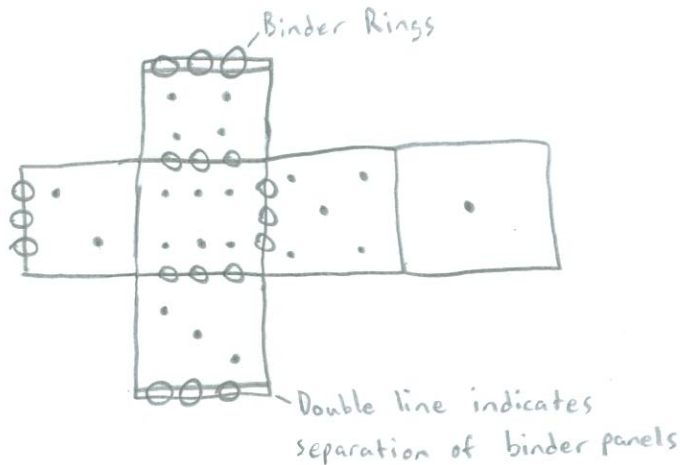

Figure 10: A sketch drawn by Dominick Triola showing the basic 2 dimensional layout for the binder blocks. The three consecutive circles represent binder rings. The double line on the edge of binder folds indicates a separation of two binder halves.

### 3.3.5 Wheat Paste Furniture

A wheat paste binder coffee table is constructed by layering the cardboard sheets from binders on top of each other with wheat paste (a mixture of vegetable starch and water) as an adhesive. The table will use the plastic from the binders as a cover, and it will use the clips as hangers or cord holders as seen in figure x.

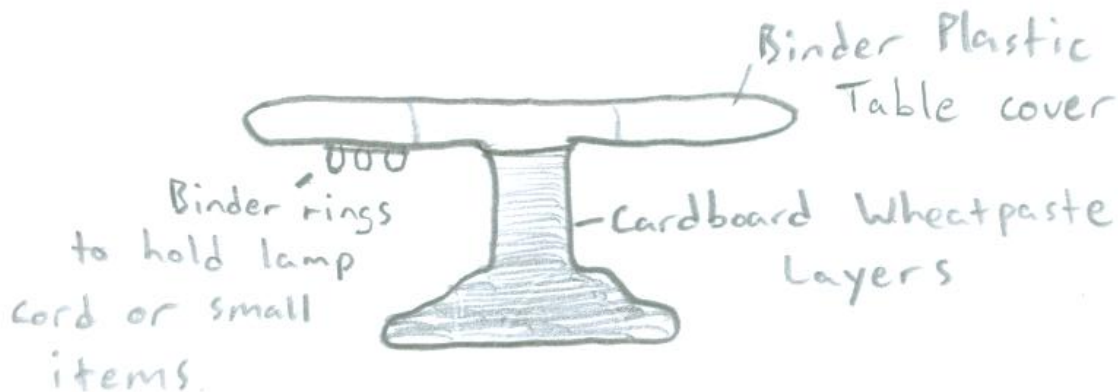
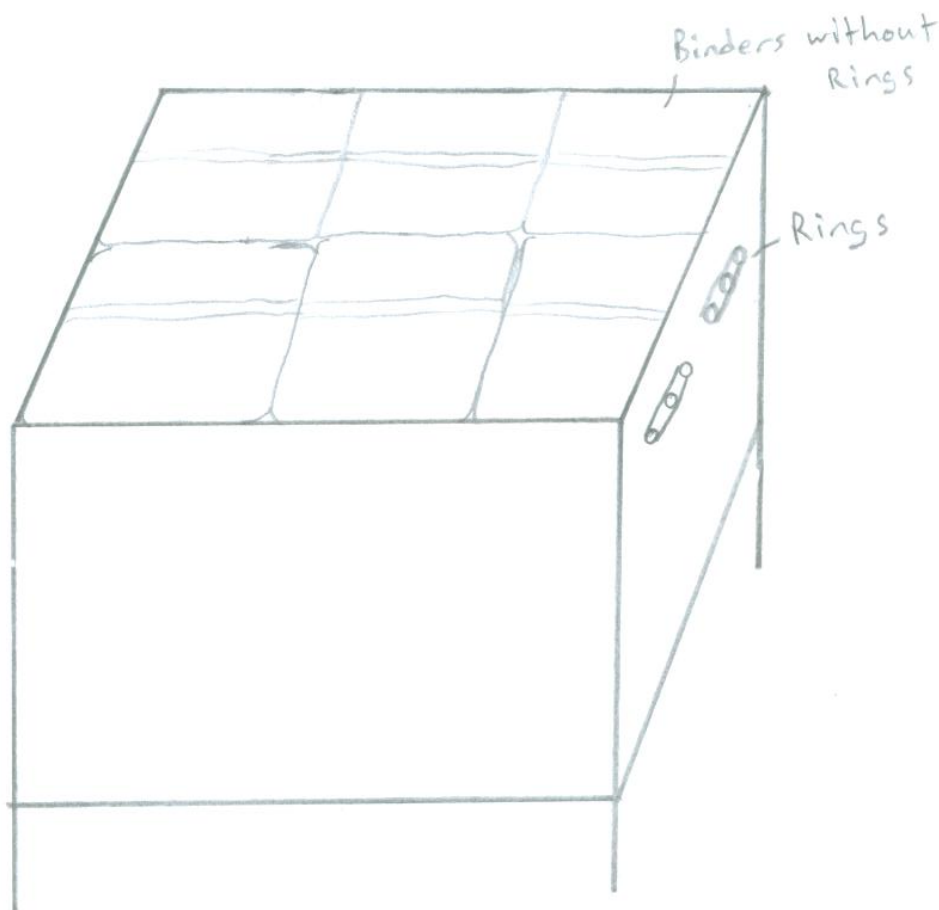

Figure 11: A sketch drawn by Dominick Triola shows the basic structure of a wheat paste table.

### 3.3.6 Replaceable Countertop Veneer for Checkout Desk

The replaceable Countertop Veneer will be made from binders with removed rings as seen in figure 12. The binders will be lain flat across the surface of the counter and small gaps between binders will be filled. The binders will be easily replaceable, because they would expire from

continued use. When necessary one binder at a time could be replaced. The binder rings will be placed around the perimeter of the desk to be used as item hangers or cold holders.

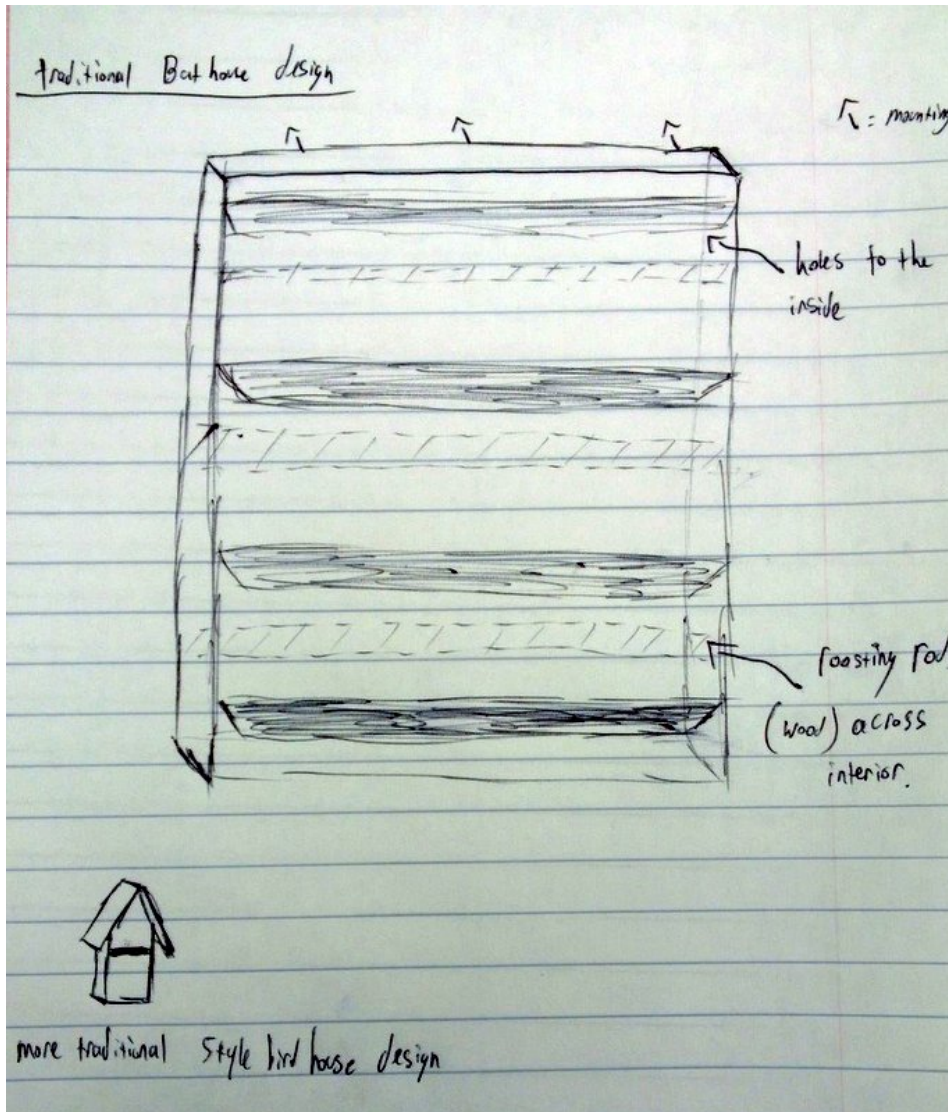

**Figure 12:** Sketch drawn by Dominick Triola shows basic layout of a binder countertop veneer with rings on sides of desk.

### 3.3.7 Binder Bird/Bat House

The Binder Bird/Bat House Will be constructed from up cycled binder parts and minimal other materials. It should be at least 20 inches tall and 14 inches wide to provide a comfortable space for the animals. The skeleton of the house will be made from poly plastic binders for maximum waterproofing and longevity. The inside of the skeleton can be lined with the cardboard found inside vinyl binders for insulation to keep the inside warmer than the colder outside temperatures. As seen in figure 13, the modern bat house design comprises of several entrance slits into the bat house. The bats could then roost on rods running the length of the box. If making a bird house, the more traditional style bird house design would be used, and instead of a slit opening, the opening would be one solid hole in the front of the house. One must keep in mind that using any toxic glues or pressed woods can be potentially fatal to the bats, therefore

being thorough with construction is a necessity.



**Figure 13:** A sample of two separate designs drawn by Jacob Burns. The bigger of the two is an example of a modern bat house with roost rods in the interior. The smaller picture is a sample of a traditional bird house.

### 3.3.8 Binder Bird Feeder

The Binder Bird Feeder as shown in figure 14 will utilize binder spines more than the skeleton of the binder itself. The binder spine will be secured to a branch or other type of support and clipped into another spine. Pinecones can then be hung from the secured spine after being rolled in peanut butter or any other type of food adhesive. The lathered cone will then be rolled in bird feed and secured to the hanging spines. The reasoning behind securing two spines is so that when the cones have been used up, the spine can be easily taken down for maintenance, or to secure new cones with more feed. This project is the result of low cost operations and can be

used by any age group.

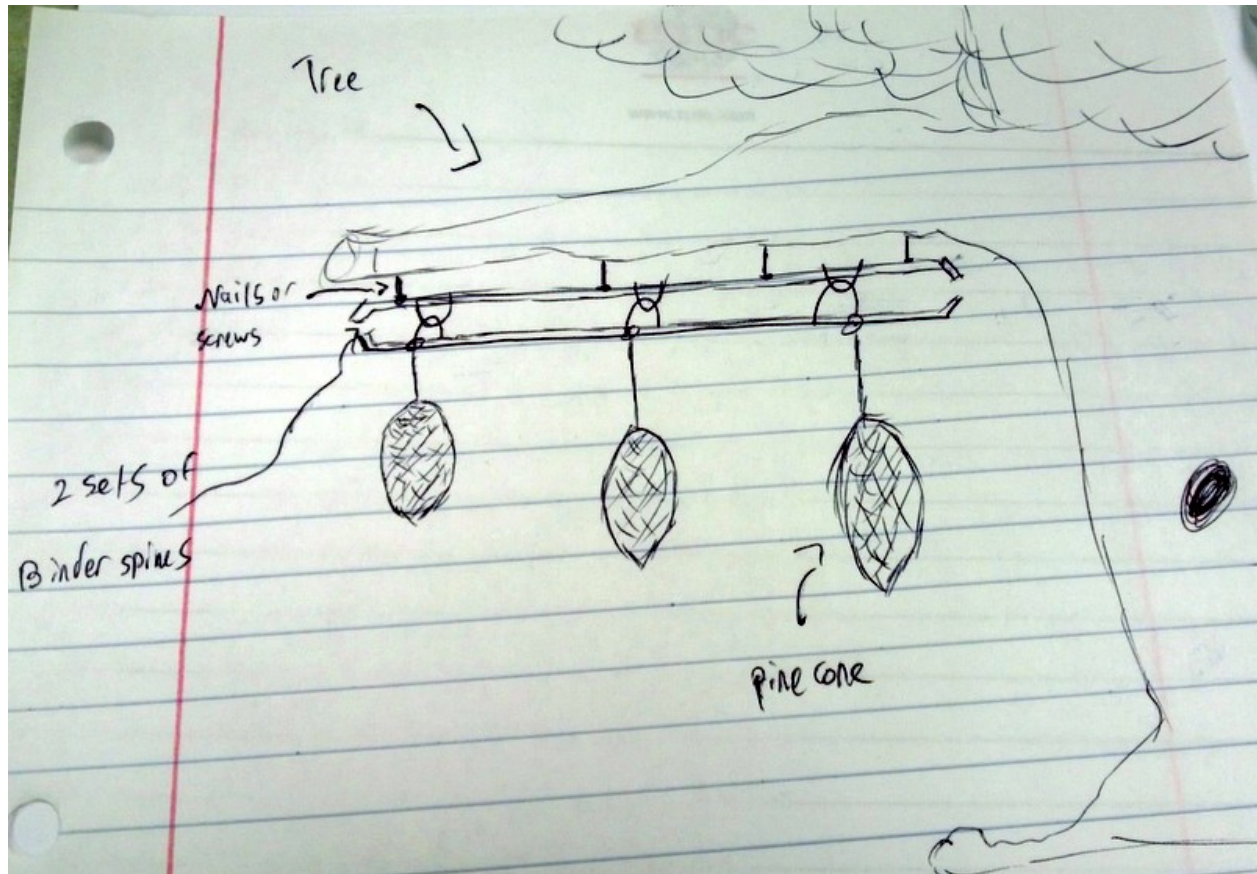

Figure 14: A simple picture drawn by Jacob Burns that shows how the bird feeders can be secured and hung from a tree. There are two sets of binder spines so that one can be taken down for maintenance and re-rolled with more feed.

## 4 Final Decision

### 4.1 Introduction

Section four identifies and justifies the final decision for the project. The justifications are made based on criteria, client feedback, and the Delphi comparison method.

### 4.2 Criteria

- **Cost:** is weighted with cheaper being better, and it must be at least under budget, which is set at around ten dollars.
- **Environmental Impact:** is judged based on embedded energy and toxicity of materials required to construct the project. Less energy and toxicity is better.

- **Amount of recycled material used:** This criterion is based on the percentage of recycled material used to construct the project, with a higher value given to a higher percentage of recycled material.
- **Recreatable:** The project will be weighted higher if it is easy to recreate by a wide range of potentially interested people.
- **Aesthetics:** Aesthetics are judged based on how appealing the project will look. It must at least appear trustable and good enough to spark an interest in people.
- **Longevity:** Stability is judged based on the expected durability of the project, or whether or not the project is easily replaceable or meant to be replaced.
- **Number of binders used:** The goal is to create a project that will be recreated. Therefore, projects that use fewer binders will be valued higher, because ease of use is important regarding our target audience.
- **Practicality:** Practicality is judged based on usefulness, likeliness of continued use, and actual need.

### 4.3 Alternative Solutions

The best eight alternative solutions were analyzed and considered before the final decision was made. These solutions are as follows:

- Board Game (3.3.1)
- All book No Hands (3.3.2)
- Umbrella Hat (section 3.3.3)
- Binder Dice (3.3.4)
- Binder Furniture (3.3.5)
- Countertop Veneer (3.3.6)
- Bat House (3.3.7)
- Bird Feeder (3.3.8)

### 4.4 Decision Process

A Delphi Matrix, shown in Table 2, is used to determine the best possible solution to the given up-cycling challenge. Each alternative solution is given a score from 0-50 (50 being most important) for each criterion. That score is then multiplied by that criteria's specific weight which has a value from 0-10 (10 being most important) shown in Table 2. The remaining scores are then added together to produce a total score for each solution. During the assigning of scores the weight of each criterion is hidden to minimize bias. The final scores help determine an unbiased best likely solution for the client.

**Table 2: Shows the Delphi chart comparison for each alternative solution.**

Criteria	Weight (0-10)	Alternative Solutions (0-50)							
		Umbrella Hat	All Book No Hands	Board Game	Binder Dice	Binder Furniture	Countertop Veneer	Bat House	Bird Feeder
Cost	6	10	35	25	35	5	35	10	30
		60	210	150	210	30	210	60	180
Environmental Impact	5	20	40	40	45	40	50	20	40
		100	200	200	225	200	250	100	200
Amount of Recycled Material Used (%)	8	40	45	50	50	25	40	25	50
		320	360	400	400	200	320	200	400
Recreatibility	7	15	45	45	50	10	45	25	50
		105	315	315	350	70	315	175	350
Aesthetics	4	15	15	30	30	5	35	40	45
		60	60	120	120	20	140	160	180
Longevity	6	15	45	40	40	35	50	20	50
		90	270	240	240	210	300	120	300
# of Binders per Project	5	40	50	15	35	5	15	20	40
		200	250	75	175	25	75	100	200
Practicality	10	5	45	20	20	5	40	30	35
		50	450	200	200	50	400	300	350
Totals		985	2115	1700	1920	805	2010	1215	2160

### 4.5 Final Decision

The final decision is that the All Book No Hands will be the constructed project. All Book No Hands scored high on the Delphi chart, and it is one of the top two choices of the client. The bird feeder scored higher than All Book No Hands, but it was not valued highly by the client because of its simplicity. The countertop veneer also scored high on the Delphi chart but it was also not valued highly by the client because of its simplicity. The Bat House and All Book No Hands are the client favorites for their uniqueness and practicality. Since All Book No Hands scored highest on the Delphi chart out of the client's favorite projects, it is the final solution.

## 5 Specification of Solution

### 5.1 Introduction

Section 5 of this document states the finer details of the final solution chosen for the client. A description is given for the solution including all specifications for every aspect. The cost will be judged based upon time, materials, and labor. Construction and use instructions will be included for further implementation as well as results for final prototypes.

### 5.2 Solution Description

In order to give binders a new and valuable purpose to keep them out of the waste stream the idea of a book holder was created. The book holder utilizing skewers for optimal viewing, a book light for nighttime reading, and the use of straps to hold any size book.

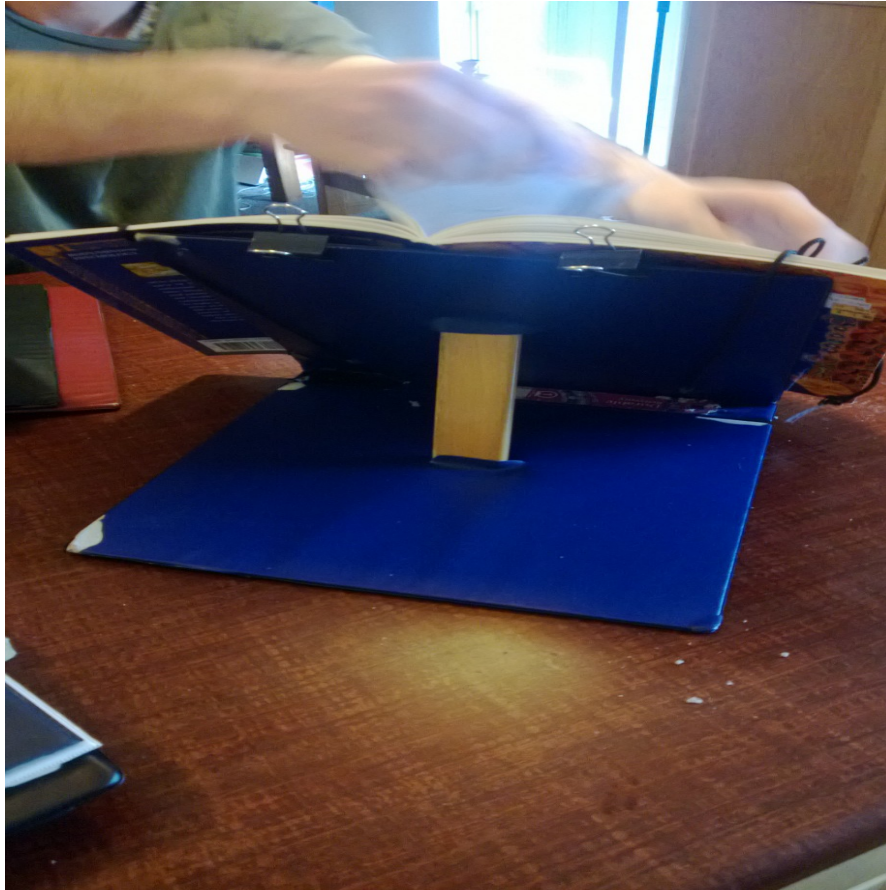

**Figure 15: Back of Book Stand**

### **5.2.1 The Stand**

To create the stand the binder must be still be in good condition and have both flaps firmly attached to the centerfold. Bend the binder backwards so that the 3 rings are facing outward. Measure the skewer or scrap wood to the length of the angle desired. Cut folds into plastic cover where position of skewer or scrap is desired on both top and bottom flaps. Slide skewer or scrap wood into folds and let the binder fall into place.



Figure 16: Front of Book Stand

### 5.2.2 Attaching the Book

To attach the book to the top flap slits must be cut into the top flap using either a knife or scissors. These should be placed as close to the edge of the flaps as possible and as close to the 3 rings in order to keep the Velcro or string off of the text. The book should then be held down using binder clips on none text pages then the Velcro or string should be slid through the cut and fastened tightly to the book. For smaller books where Velcro and string can obscure the text while not being able to as effectively hold the book down a weight can be attached to some string and another hole in the center top of the top flap can be made for the string attached to the weight to be fastened to. This should allow the book to be held open while also keeping the intended page open.

### 5.2.3 Book Light with on/off Switch

The book light shown in Figure 17 is made from a simple diode and a 3032 battery. The diode has permanent contact with the negative side of the battery, while there are pieces of card stock (thick paper) that surround the positive terminal of the diode on both sides. The Battery and diode is wrapped with duct tape to ensure structural integrity, and to make sure that the diode is in contact with the battery. The inner piece of cardstock is removed when the user wants light and is easily replaced to disrupt contact between positive terminals to turn the light off.

Figure 17: Book Light with switch removed



## 5.3 Cost Analysis

The cost analysis is represented by the cost of materials which is the research and development costs, the cost of maintenance or the upkeep of the All Book No Hands, and the cost of design hours which is labor hours.

### 5.3.1 Design Cost

The cost of design is represented by human work hours, meaning the more time members put into the project, the higher the cost. Roughly half of the total design hours were spent on putting the project together in Section Five, yet the total time spent on the project was relatively even. The total design hours are shown in Figure 18.

**Figure 18: Total Labor Hours on the All Book No Hands**

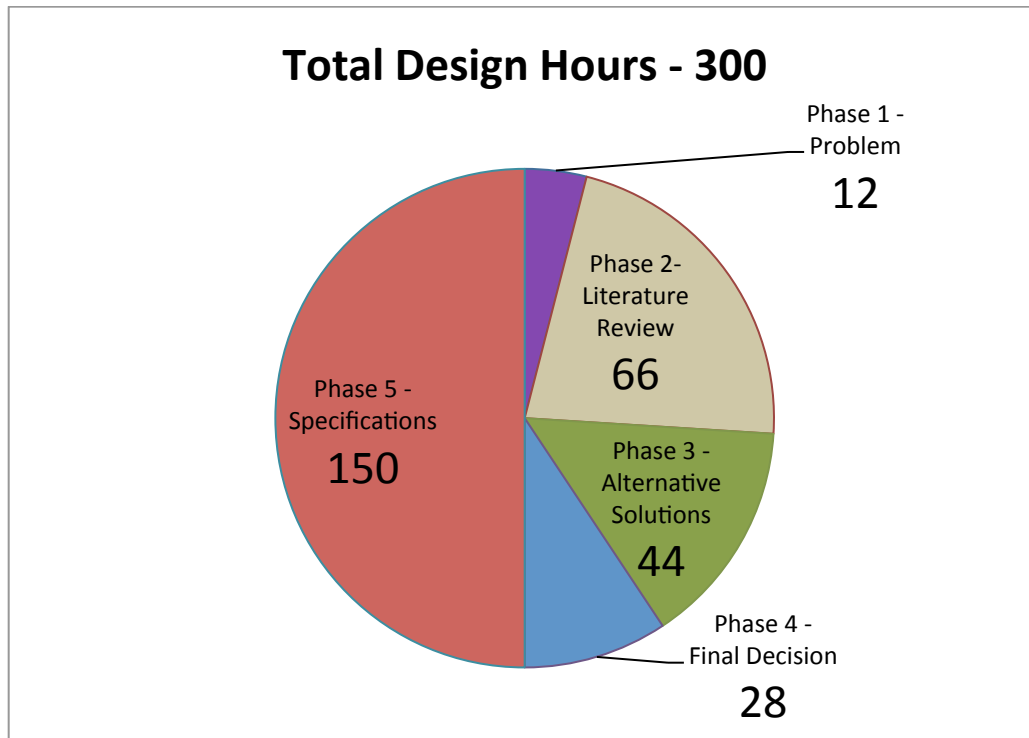

### 5.3.2 Implementation Cost

The list of total material costs is represented in Table 3 for the all book no hands. The total cost came out to about \$6.00, which seems low for the amount of time put into the product. The overall cost appears successful when compared to the projected cost of \$91.74.

**Table 3: Cost of Materials for the All Book No Hands**

Item	Quantity	Team Cost	Retail Cost
Batteries (Sets)	3	\$1.00	\$1.00
Binders	10	Donated	\$2.00
Binder Pieces	6	Donated	NA
Velcro Straps	2	Donated	\$5.00
Scewers (Pack)	1	\$2.99	\$2.99
Binder Clips	10	Donated	\$1.50
Scrap Wood	1	Donated	\$20.00

Tape	1	Donated	\$3.00
Paper	1	Donated	\$0.25
Solder & Iron	1	Donated	\$20.00
String	1	Donated	\$1.00
Weights	1	Donated	\$10.00
Books	1	Donated	\$25.00
Total Cost		\$5.99	\$91.74

### 5.3.3 Maintenance Cost

The cost of maintenance is projected to never be represented by the whole product, meaning that only pieces have to be replaced, never the whole product. In this case, refer to Table 3 for a list of costs for each part involved in the building of All Book No Hands. Replacing each part is minute and should only take a few minutes. Complete maintenance with the all book no hands in negligible.

## 5.4 Instructions for Implementation and Use of Model

### 5.4.1 Book holder construction instructions

#### 5.4.1.1 Required materials

- 3 Ring Binder

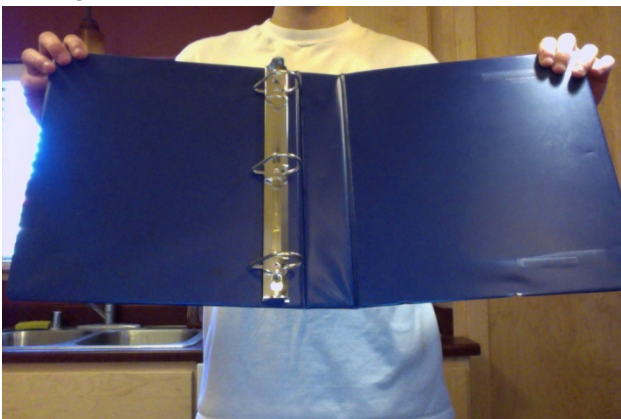

(3 Ring Binder) (Sample pic from [www.myfico.com](http://www.myfico.com))

- Velcro



- String



- 2 skewers



- Object that weighs about 50-100 grams and can be fastened to a string



- Glue



- Tape



- Scissors



#### *5.4.1.2 Step 1*

Fold binder inside out and decide which binder flap will be the base of the All Book No Hands device. This will only matter if the rings are not fastened in a symmetrical location in the binder. Glue flat 9" wood piece on top of rings to create a resting spot for books.



**Figure 19: Shows correct binder orientation with wood book seat.**

#### **5.4.1.3 Step 2**

Cut slits above wood seat to feed Velcro or string through. Leave at least 1" of binder at outer edges of slits and a few inches in the middle. Tape the edges of the slits to provide durability and make it easier for Velcro or string to move within the slits.



**Figure 20: Taping the slits**

#### **5.4.1.4 Step 3**

Cut small holes in the vinyl or plastic of the back of the front binder panel and glue zipper pieces or hinges to cardboard. Cut skewers to a length of 5" and glue to zipper pieces or hinges.



**Figure 21: Fastening skewers to back of front panel.**

#### **5.4.1.5 Step 4**

Cut holes to fit skewers or 5" wood pieces in the vinyl or plastic of the base panel of the binder at different locations to provide varying degrees the front panel can be fixed at.



**Figure 22: Locations of base panel holes**

#### **5.4.1.6 Step 5**

Cut 2 holes in the top edge of the front panel about 4" from each outer edge. Tie a length of string to each hole, and tie the weight to each string. These will provide an easier way to keep book open when there are only a few pages on a particular side.

#### **5.4.1.7 Consideration**

This is designed to be easily replicable, and the design will still be functional without some of the steps like attaching hinges (just place skewers where hinges would otherwise go), or adding weights, but it works more reliably if every step is followed. Additional flourishes can be added like covering the binder in an aesthetically pleasing material.

### **5.4.2 Instructions for Use**

Place book on book stand. Feed Velcro or string through slits and fasten book to binder with the Velcro or string. If it is easier use weights to hold pages open. This is usually the case in the early and latter stages of a book. Large books like text books may not need to be held open by weights or Velcro, and the All Book No Hands can serve as a simple inclined book holder.

### **5.4.3 Repair**

If maintenance is required refer to the step in the instruction section for the piece that needs to be replaced, and reassemble the faulty part of the All Book No Hands following the same steps as before. The steps can be done independently of each other, so if one piece breaks the entire device does not need to be reconstructed.

## **5.5 Results**

Final prototypes yielded results that showed relative effectiveness at holding a book in place while allowing the user to be as close to hand free as possible. The string is slightly less obscuring than the Velcro but is less secure and not as easily changed. The skewers performed better than scrap wood being able to be on both sides and are easily slid into cuts in the plastic but require being purchased versus being found or reused. Books to use are best when with wider pages. The smaller the width of the book the more difficult it becomes for the Velcro or string to hold it down. In cases such as these it is recommended that a hole be made at the top of the top flap and a string with a weight being fastened to the top hole and used a page holder for these more difficult books.

# 6 Appendix

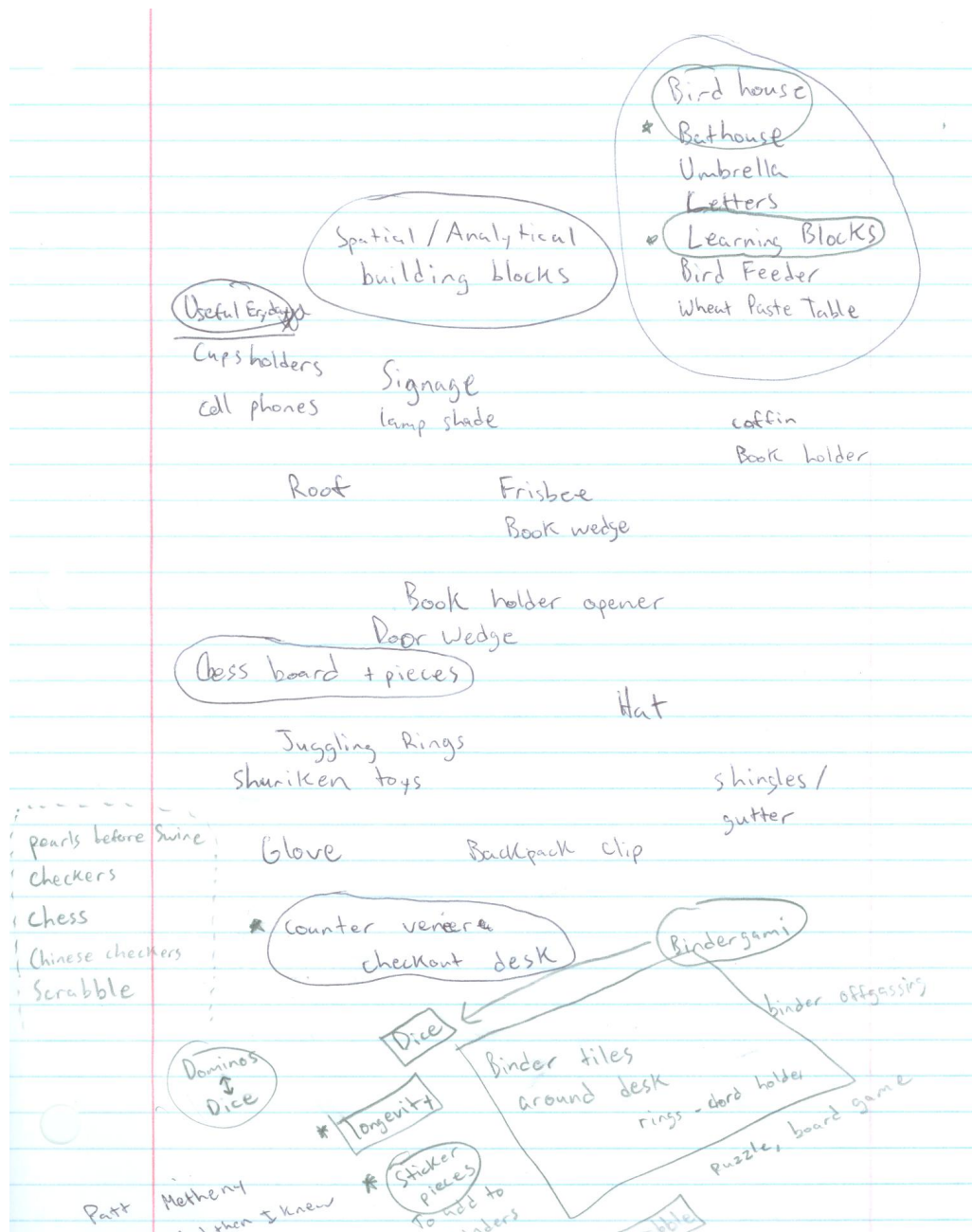

Figure 23: Unstructured Brainstorm

Brainstorm

Binders	Spine	cardboard
Umbrellas	hanger	bird houses
Waterproof jackets		cardboard vet?
waterproof bag	jewelry	
recycled paper	bird feeder	
solar cooker		
tote bag		

longevity of plastic  
 other ideas  
 durability of binder plastic  
 Notebooks in waste stream

ROSE Reusable Office Supply Exchange  
 Binder components  
 bird house dimensions

Bird house + feeders \*  
 Umbrellas \*

will birds live in color/plastic house?

Me: local birds, Tote bags  
 dimensions, jacket?  
 hangers, recycled paper?  
 binder components, jewelry  
 wheat paste

S: longevity, binders,  
 Umbrellas, components  
 other projects  
 Binders in waste stream  
 wheat paste

J: Binder ring  
 Durability of plastic  
 rainfall, climat.  
 bats, bat houses

Gumbo for fertilizer?  
 weather proofing? + weather

Figure 24: Unstructured Brainstorm

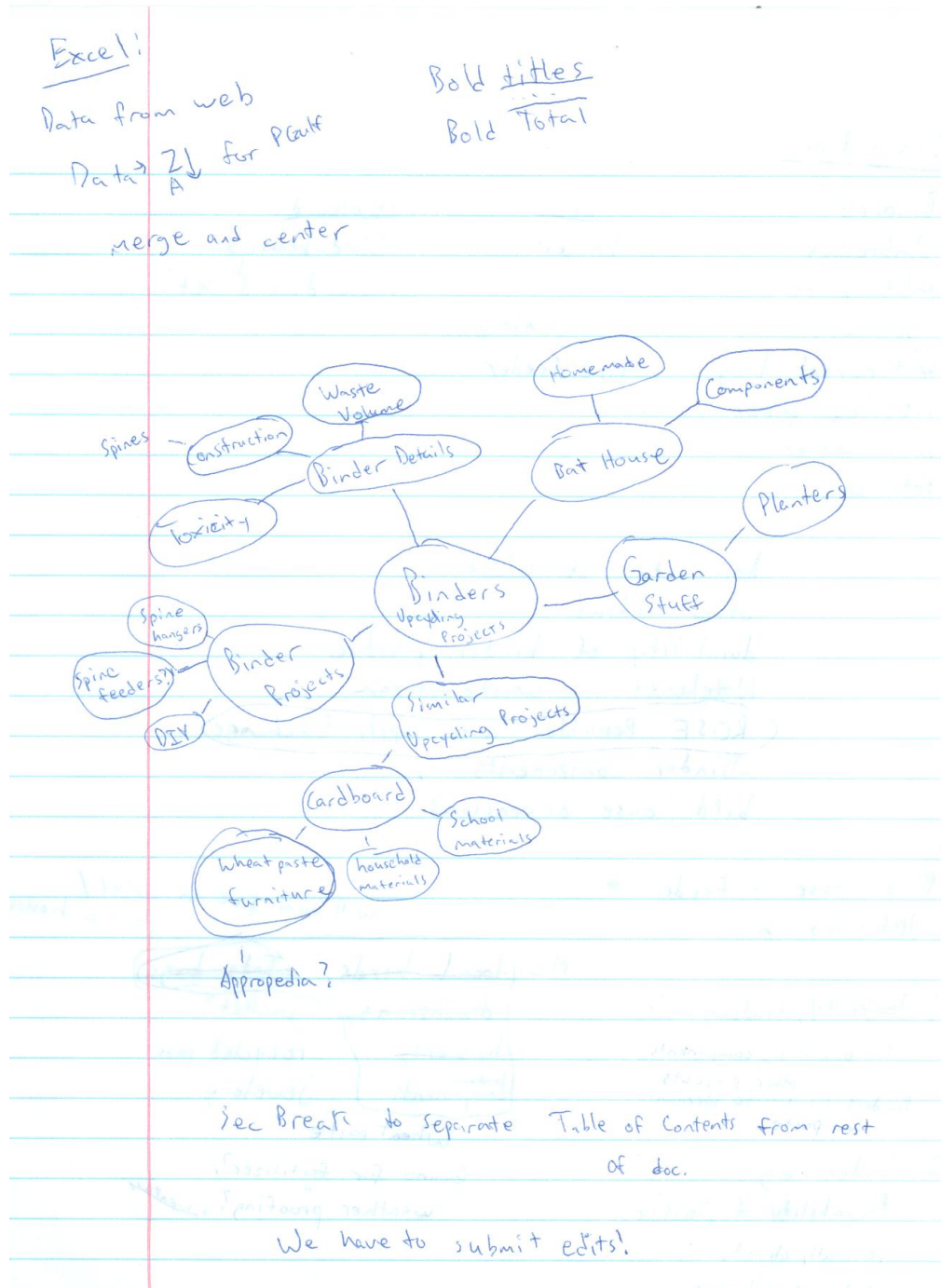

Figure 25: Structured brainstorm using expanding bubbles.

## 7 Works Cited

Cornell Lab of Ornithology. (2013a). "Habitat Requirements." <[http://www.birds.cornell.edu/nestinginfo/bios/nest\\_require/habitat](http://www.birds.cornell.edu/nestinginfo/bios/nest_require/habitat)> (Feb. 23, 2013).

Cornell Lab of Ornithology. (2013b). "Species Accounts." <[http://www.birds.cornell.edu/nestinginfo/bios/sp\\_accts/](http://www.birds.cornell.edu/nestinginfo/bios/sp_accts/)> (Feb. 23, 2013).

Cornell Lab of Ornithology. (n.d.). "Entrance Hole Sizes for Songbird, Woodpecker, and Squirrel Nest Boxes." <[http://www.birds.cornell.edu/nestinginfo/downloads/songbird\\_holesize.pdf](http://www.birds.cornell.edu/nestinginfo/downloads/songbird_holesize.pdf)> (Feb. 23, 2013).

coville123. (n.d.). "Reusing 3-Ring Binders." *ThriftyFun*, <<http://www.thriftyfun.com/tf19107960.tip.html>> (Feb. 23, 2013).

dansken. (n.d.). "Very cheap knife holder if you have a spare ring binder." <[http://www.reddit.com/r/Frugal/comments/15mlak/very\\_cheap\\_knife\\_holder\\_if\\_you\\_have\\_a\\_spare\\_ring/](http://www.reddit.com/r/Frugal/comments/15mlak/very_cheap_knife_holder_if_you_have_a_spare_ring/)> (Feb. 23, 2013).

García-Navas, V., Arroyo, L., José Sanz, J., and Díaz, M. (2008). "Effect of nestbox type on occupancy and breeding biology of Tree Sparrows *Passer montanus* in central Spain." *Ibis*, 150(2), 356–364.

Hassinger, J. (1994). *Woodcrafting for Wildlife: Homes for Birds and Mammals*. Pennsylvania Wild Resource Fund & Pennsylvania Game Commission.

Klick, J., and Wright, J. D. (2012). *Grocery Bag Bans and Foodborne Illness*. University of Texas.

Woodworking, P. (Ed.). (2004). *Birdhouses You Can Build in a Day*. Popular Woodworking Books.

Bodeeb, Julia. (2010). "Ideas to Reuse a 3 Ring Binder Notebook." <  
<http://www.brighthub.com/environment/green-living/articles/61560.aspx>> (Feb. 26, 2013).

"California Bat Species." *California Bat Species*. Falcon Services, n.d. Web. 26 Feb. 2013.

"FAQs." *Vinyl Binders, 3 Ring Binders, Binders Inc.* -. Binders Inc., n.d. Web. 26 Feb. 2013.

Huang, Jessica. (2011). "How to Make a Homemade Umbrella." <  
<http://www.ask.com/explore/how-make-homemade-umbrella>> (Feb. 26, 2013).

"Humboldt County, California." *Humboldt County, California*. N.p., n.d. Web. 26 Feb. 2013.

"HUMBOLDT COUNTY CALIFORNIA'S REDWOOD COAST." *Redwood Coast Climate, Humboldt County, California*. N.p., n.d. Web. 26 Feb. 2013.

Jagt, Van der. (1988). "Assembly of Ring Binders and Resulting Product." <  
<http://www.google.com/patents/US4722628?printsec=drawing&dq=3+ring+binders+details#v=onepage&q&f=false>> (Feb. 26, 2013).

Kiser, Mark. N.p.: University of Texas, n.d. *Google Books*. Bat Conservation International, 2004. Web. 26 Feb. 2013.

"Polyvinyl Chloride (PVC)." < <http://www.plasticmoulding.ca/polymers/pvc.htm>> (Feb. 26, 2013).

Reinhart. (2004). "Determining the Chemical Composition of Solid Waste." <  
<http://msw.cecs.ucf.edu/Exercise-Chemcomposition.pdf>> (Feb. 26, 2013).

"Why Bat Houses May Fail." *Why Bat Houses May Fail*. Bat Management, n.d. Web. 26 Feb. 2013.

(1995). "Recycled Content Products Directory Product Profile." <  
<http://www.calrecycle.ca.gov/rcp/BrandDetail.asp?ProductID=7437>> (Feb. 26, 2013).

(2000). "Office Supplies - PVC-Free 3-Ring Binders." *Sustainable Hospitals*, <  
[http://www.sustainablehospitals.org/cgi-bin/DB\\_Report.cgi?px=M&rpt=Subcat&id=10!33](http://www.sustainablehospitals.org/cgi-bin/DB_Report.cgi?px=M&rpt=Subcat&id=10!33)>  
(Feb. 26, 2013).

(2007. "Vinyl chloride." < <http://www.epa.gov/ttnatwo1/hlthef/vinylchl.html>> (Feb. 26, 2013)

(2010). "Doing More with Less: A Teacher's Perspective." <  
<http://www.ed.gov/blog/2010/11/doing-more-with-less-a-teachers-perspective/>> (Feb. 26, 2013).

(2013). "SCRAP History." < <http://scrappdx.org/about/history/>> (Feb. 26, 2013).