

Table of Contents

1 Problem Formulation	5
1.1 Introduction.....	5
1.2 Background.....	5
1.3 Objective Statement	5
1.3.1 Blackbox Diagram	5
2 Problem Analysis and Literature Review	6
2.1 Introduction to the Problem Analysis	6
2.1.1 Specifications	6
2.1.2 Considerations.....	6
2.1.3 Criteria	6
2.1.4 Usage.....	7
2.1.5 Production Volume	7
2.2 Client Criteria.....	7
2.3 Child Development	7
2.3.1 Pedagogy.....	7
2.4 Conductivity.....	10
2.4.1 Principles.....	10
2.4.2 AC Sources	10
2.4.3 Principles of Conductivity	10
2.4.4 Conductivity in solution.....	11
2.4.5 Temperature	12
2.5 Example Projects	13
2.5.1 Current Conductivity Meter Model	13
2.5.2 Past ENGR 215 Project Involving Education in Science	13
2.5.3 Probes.....	13
3 Alternative Solutions	14
3.1 Introduction.....	14
3.2 Brainstorming	14
3.3 Alternative Solutions	14
3.3.1 Conductivity Cannon	15
3.3.2 The Lighthouse	15
3.3.3 Colored Chest.....	16

3.3.4 Light Chest.....	17
3.3.5 The Egg.....	17
3.3.6 Spectrums.....	18
4. Decision	19
4.1 Introduction.....	19
4.2 Criteria	20
4.3 Solutions	20
4.4 Decision Process	20
4.5 Decision Justification.....	22
5 Specifications.....	22
5.1 Introduction.....	22
5.2 Material Testing	22
5.2.1 Probe Metal Selection: Disc.....	23
5.2.2 Probe Metal Selection: Rod	23
5.2.3 Light Bulb Selection	24
5.3 Description of Solution	25
5.3.1 Wooden Body	25
5.3.2 Rooftop Housing.....	26
5.3.3 Probe Block and Slider	26
5.3.4 Electrical Circuit	27
5.4 Costs.....	27
5.4.1 Design Costs	28
5.4.2 Materials Costs.....	28
5.4.3 Maintenance Costs.....	29
5.5 Instructions for Implementation and Use of Model.....	29
5.6 Results.....	30

Figure 1-1 Black Box Model that shows what the goal is of Current Wave	5
Figure 2-1 Four stages in experiential learning (National Council of Educational Research and Training 2013).	8
Figure 2-2 A Collaborative Learning Set Up in a Classroom (National Council of Educational Research and Training 2013).	8
Figure 2-3 Compares intelligent male and female students' mean conceptual understanding vs mean quantitative understanding in standard-curriculum classes (dark gray) and a qualitative-friendly curriculum (light gray)(Stern et al. 2018).	9
Figure 2-4 Flow of electrons in solution (Radiometer Analytical 2004).	12
Figure 2-5 Contact Conductivity Sensor (left) and Inductive Conductivity Sensor (right) (https://www.yokogawa.com/us/solutions/products-platforms/process-analyzers/liquid-analyzers/conductivity-sensors/)	14
Figure 3-1 The Conductivity Cannon consists of a simple DC closed circuit loop, and has a qualitative display consisting of a low-voltage dimmer lightbulb illuminating its mouth.	15
Figure 3-2 The Lighthouse consists of a closed DC circuit, with a lever so that the user does not touch any of the electronics. Upon pulling the lever and inserting the probe into a high salinity solution, the top of the tower is illuminated by a low-voltage.....	16
Figure 3-3 The Colored Chest is shown with a red glow, indicating a solution with low conductivity (design by Marco Gudino)	17
Figure 3-4 The Light Chest is a modification of the Colored Chest, using dimmer lightbulbs in a parallel circuit rather than a microcontroller and colored LEDs (Design by Marco Gudino)	17
Figure 3-5 The Egg stands at about 15 inches in height, with a casing to protect the bulbs from damage during use (Design by Leith Butler)	18
Figure 3-6 Body and container variant of Spectrums of Conductivity (Design by Kush Rawal)	18
Figure 3-7 A meter display is the first of two six-colored light bars for Spectrums (Design by Kush Rawal).....	19
Figure 3-8 The Spectrum's Rainbow Display is an alternative to the Spectrums Meter Display, using fiber-optics to generate a rainbow visual to the user. (Design by Kush Rawal)	19
Figure 5-1 Evolution of Lighthouse Bodies.....	25
Figure 5-2 Rooftop Housing Screwed on Lighthouse	26
Figure 5-3 Side of lighthouse. Shows wingnut, washer, and slider handle	27
Figure 5-4 Schematic of Lighthouse	27
Figure 5-5 Referencing Table 5-4 -- Percentages of time spent on each section	28

Table 2-1 Criteria for a new conductivity probe design is rated in order of importance on a scale of 1 to 10.	6
Table 2-2 Temperature Coefficient of Variation for Common Solutions (https://www.camlab.co.uk/originalimages/sitefiles/tech_papers/tempcndmeas.pdf)	12
Table 4-1 Weighted Criteria used for Delphi Matrix.....	21
Table 4-2 Delphi Matrix of Each Alternative Design (made by Caleb Dedmore)	22
Table 5-1 Results of the oxidation test of various metal discs. A 9.28V DC charge was inputted on two discs of each metal for a duration of 30 minutes while submerged in a 2M NaCl solution to asses mass loss due to oxidation.	23

1 Problem Formulation

1.1 Introduction

Section 1 provides a background of the conductivity probe being completed, an objective statement formed by Current Wave, as well as a black-box model showing the overall purpose of the project.

1.2 Background

Six Rivers Charter School has a chemistry course which uses a device to measure the conductivity of multiple solutions. Over time, this device has corroded, covering the probes of the device in rust. Team Current Wave is working directly with Shannon Morago, an instructor in HSU's School of Education and Chemistry teacher at Six Rivers Charter School. (Will insert more about the client)

1.3 Objective Statement

The objective of this design project is to produce a conductivity probe for the use of Six Rivers Charter School in Arcata, CA. The chemistry department of Six Rivers Charter School will use the probe to measure the conductivity of various liquids, as well as use the probe as a teaching mechanism for students. Therefore, it is essential to design a conductivity probe that is not only accurate, but that also facilitates learning for the students, can be handled by inexperienced users without easily breaking, and can provide easy usability. The goals and criteria for this design will be determined by Shannon Morago.

1.3.1 Blackbox Diagram

A black-box model was used to determine the ultimate goal to achieve with Six Rivers Charter School. Figure 1-1 displays this model.

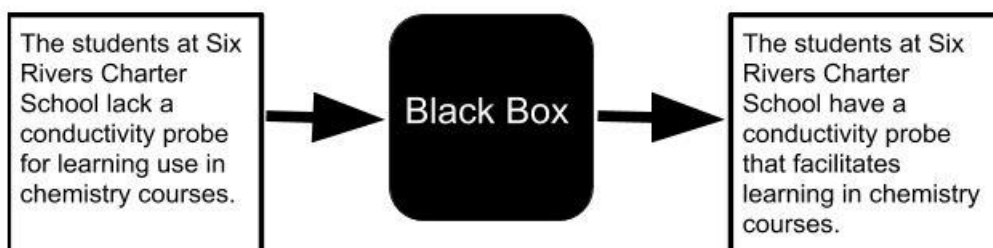

Figure 1-1 Black Box Model that shows what the goal is of Current Wave

2 Problem Analysis and Literature Review

2.1 Introduction to the Problem Analysis

2.1.1 Specifications

Dr. Morago would like to see each probe stand up with a height of one or two feet, that can stand on a table and be plugged into a nearby wall outlet.

2.1.2 Considerations

The probes will be used for a few labs each semester, and then stored for possibly long periods of time. Students could potentially break sensitive equipment, and the past conductivity meter model was too small for some of the past students' hands.

2.1.3 Criteria

The criteria listed in Table 2-1 was made by incorporating criteria from both Arcata High School and Current Wave.

Table 2-1 Criteria for a new conductivity probe design is rated in order of importance on a scale of 1 to 10.

Criteria	Constraint	Weight
Safety	Must not physically injure the user (including shocks, cuts, etc.)	10
Durability	Lasts longer than 5 years (other than replacement bulbs)	7
Level of Engagement	Must be a visually pleasing display that captures the attention of the user/class	9
Ease of Repair	No more than a one-page long repair sheet, no background knowledge required for repair	8
Cost	<\$50 per probe	7
Aesthetics	More visually pleasing than the previous class model	4
Educational Value	Must be able to teach students basic conductivity principles at a high school level	5
Inspirational Value	Must instill a curiosity in class that may lead students to having a higher level of interest in science.	4

2.1.4 Usage

The proposed design will be used by Arcata High School to conduct lab experiments in chemistry class a few times a semester. Students will use the conductivity probe hands on, one at a time. The probe will also be used for class presentations conducted by the teacher.

2.1.5 Production Volume

Four productivity probes will be built for the chemistry class. This will allow the lab to be conducted in a more efficient and timely manner than before.

2.2 Client Criteria

Dr. Morago serves as the liaison for the client, Arcata High School. She has requested the following criteria:

- Qualitative data - as it engages students, helps them better understand the topics presented, and contributes to a more enjoyable learning experience.
- A height of about 1 foot so that students can see presentations involving the conductivity meter.
- Large light bulb, or some other bold form of display to captivate the student audience.
- Multiple devices so the whole class can participate simultaneously (about 4).

Along with these requirements, Dr. Morago also has some preferences. She would prefer a structure that would allow students with large hands to place beakers underneath the prongs, a simple device that would be easy to repair if anything gets damaged, and an aesthetically appealing device (S. Morago, personal communication October 1, 2019).

2.3 Child Development

Exploration is a contributing factor in improving the engagement of students in class. Students are asking to find answers and solutions for themselves. Now, learners want more hands-on experience rather than absorbing information from their instructors. (Parsons, Taylor 2011) Another contributing factor in improving engagement is relevance. Learners are asking why they are completing certain tasks and how it is relevant to the real world. Learning tasks should require deep thinking, be connected to the world outside the classroom, have intellectual rigor, and include substantive conversation. (Parsons, Taylor 2011)

To acquire attention from students, their curiosity must be engaged. There is a phenomenon called rubbernecking which is the flow of traffic decreasing because people slow down to look at something unfamiliar on the roadside. Brains are attracted by changes in the environment. Changing the setup of a room, having interactive props, and having audio sensations engage students. (Bertha, Craft 2013)

2.3.1 Pedagogy

Real life experiences and situations are vital to the process of learning physical sciences. (National Council of Educational Research and Training 2013). Different forms of experiences

that aid in the process of learning physical sciences include performing observations and experiments and engaging in activities and projects. Figure 2-1 shows that taking part in these kinds of activities and reflecting upon them afterward helps cement abstract concepts in students' minds (National Council of Educational Research and Training 2013).

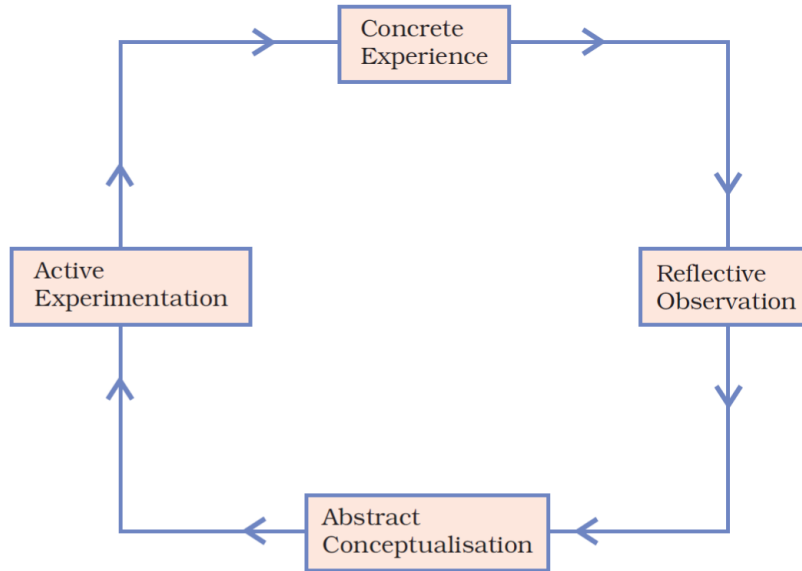

Figure 2-1 Four stages in experiential learning (National Council of Educational Research and Training 2013).

Another aspect that is vital in the process of learning physical sciences is a collaborative learning approach (National Council of Educational Research and Training 2013). Group activities such as brainstorming, group problem solving and peer-learning aid students in becoming autonomous learners and in developing collaborative social skills. A collaborative learning approach encourages critical thinking, problem solving, and effective communication of one's ideas to one's peers (National Council of Educational Research and Training 2013). Figure 2.2 demonstrates a visual demonstration of a collaborative learning environment in a classroom.

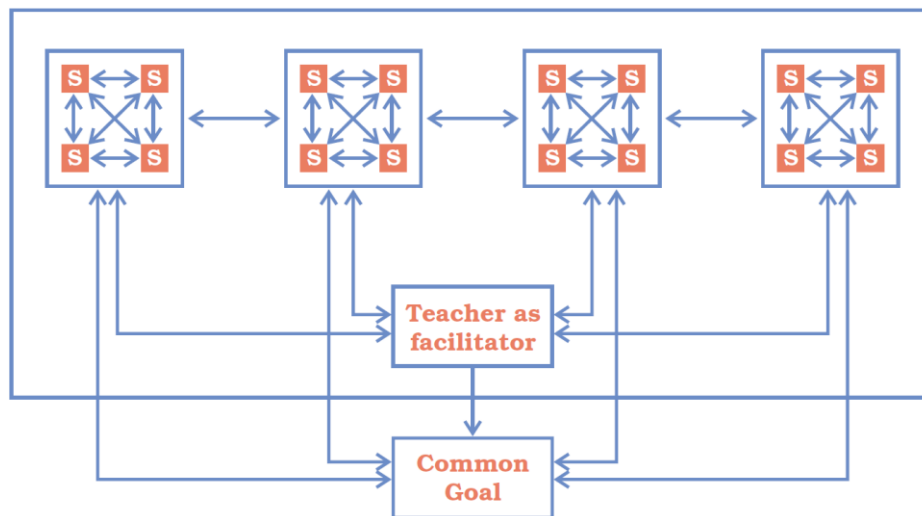

Figure 2-2 A Collaborative Learning Set Up in a Classroom (National Council of Educational Research and Training 2013).

Another method found to be effective in helping students learn physical sciences is altering teaching style to present the material in a cognitively stimulating way (Stern et al. 2018). Asking students to come up with solutions to problems that haven't been covered in the curriculum yet stimulates the students' curiosity, requires students to call back on previous knowledge and attempt to make connections, and exposes students to the limits of their own knowledge. Presenting students with two superficially similar, yet fundamentally different concepts and asking them to find these differences forces students to break these concepts down into their fundamental roots, cementing the conceptual differences in their minds (Stern et al. 2018).

Qualitative knowledge is an especially effective parameter in improving student conceptual knowledge and qualitative problem-solving performance. Students who first learned quantitative problem-solving methods then learned qualitative concepts performed worse on quantitative tests than students who learned the qualitative concepts before quantitative methods (Stern et al. 2018). The effectiveness of a curriculum which encourages qualitative conceptual teaching methods can be seen in Figure 2.3.

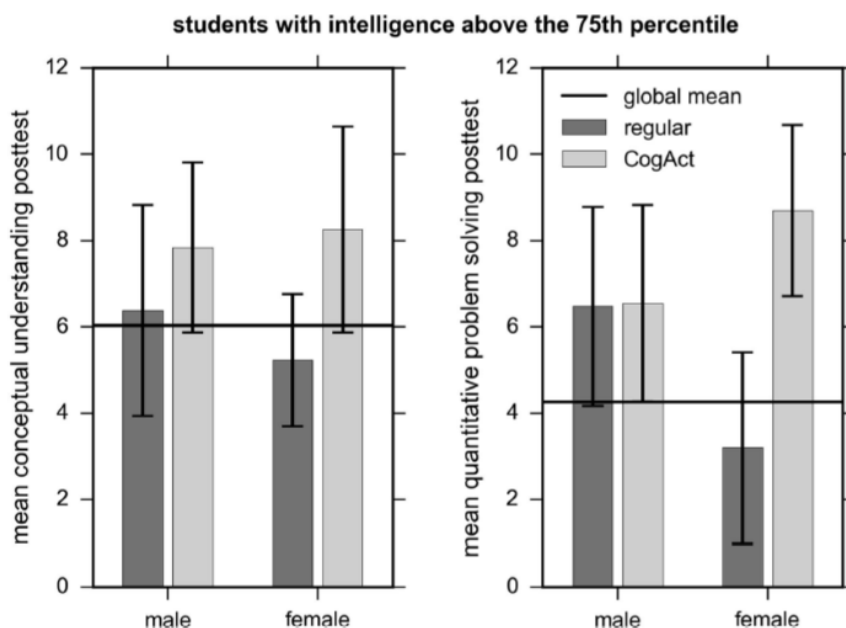

Figure 2-3 Compares intelligent male and female students' mean conceptual understanding vs mean quantitative understanding in standard-curriculum classes (dark gray) and a qualitative-friendly curriculum (light gray)(Stern et al. 2018).

This learning style is also especially effective for improving performance of female students in the physical sciences and may be able to contribute to reducing the gender gap in STEM majors (Stern et al. 2018).

Three core portions of early learning in science include the ability to reason about causal connections, knowing the parts that explain these connections, and making accurate observations (Tolmie et al. 2016). Crosscutting concepts, such as cause-and-effect relationships, tend to have high relevance in any learning field, as well as in daily life (Tolmie et al. 2016). Children learn best when they are presented with the challenge of using their problem-solving skills to find answers to questions. It is especially beneficial to their learning process when the solution

involves an interactive experience (Tolmie et al. 2016). Providing a contextualized experience in which an adult can facilitate learning can help make learning more meaningful to a student.

2.4 Conductivity

Section 2.4 separates the key components of conductivity. It is separated into principles, AC sources, principles of conductivity, and conductivity in solution.

2.4.1 Principles

A conductivity cell (a glass vessel with two electrodes at a definite distance apart and filled with a solution whose conductivity is to be measured) can be set up using what is known as a Wheatstone bridge circuit. A Wheatstone Bridge is used in probes by measuring the resistance of a solution in comparison to the other three resistors within its circuitry. One method is to alternate the resistance until current flows evenly through both sides of the bridge without crossing over the center. When this point is reached the voltage potential along the bridge is known, and one can then calculate the resistance of the solution that the probe is inserted in. In a solution, electrical current travels through dissolved ions rather than electrons. Conductivity is the inverse of resistivity, and so using Ohm's Law: A solution typically has a greater resistance than a metal would, and thus a smaller conductivity. It is best to measure the conductivity of a solution using a probe that uses alternating current rather than direct current. Direct current allows the ions in a solution to polarize over time, altering the reading for conductivity. Contrarily, alternating current prevents the solution from polarizing, and it is recommended to use an AC current that does at least 1000 cycles per second. Sawyer recommends using electrodes coated in platinum black for a higher state of balance, and electrodes made of stainless steel or another common metal when continuous or constant use is expected for the probe. Typically, conductivity is measured in micro siemens, which is. Conductivity of a solution is typically measured by comparing to a standard solution with a known resistance. In water quality, conductivity can be used to quickly calculate a rough concentration of dissolved solids in a water sample (Sawyer et al. 2003).

2.4.2 AC Sources

An AC source is an electric current alternating in voltage in a sinusoidal wave. According to *Physics for Scientists and Engineers with Modern Physics Volume Two* (Serway/Jewett 2008) AC source circuits run off an alternating current that is described by:

- $\Delta v = (\Delta V_{\max}) * (\text{SIN}(\omega * t))$, Where:
 - Δv = alternating voltage, a wave function based on time
 - ΔV_{\max} = maximum output voltage, or amplitude
 - $\omega = 2\pi/T$, T = period, the waveform frequency (rad / second)
 - t= time

2.4.3 Principles of Conductivity

Important equations

- Ohm's Law: Voltage = Resistance x Current
- Conductance: the inverse of Ohm's Law: $1 / \text{Resistance}$
- Cell Constant: $k = d/a$, Where:

- k = cell constant (cm)
- a = area of electrodes
- d = distance between electrodes
- Cable correction: $G_m = G_s / (1 + (R_c \times G_s))$, Where:
 - G_m = measured conductance (units in Siemens)
 - G_s = Solution Conductance (units in Siemens)
 - R_s = Cable resistance (units in Ohms)

(Radiometer Analytical 2004)

2.4.4 Conductivity in solution

The conductivity of a solution is its ability to carry an electric current. A solution's ability to carry an electric current is dependent on the presence of ions dissolved in the water, the concentration of ions in the solution, the valence of the ions present, and the temperature of the solution. (Radiometer Analytical 2004). Conductive solutions include acids, bases and salts due to their abundance of charged ions needed to pass along the electric current. Conductive solutions most often occur in due to the water molecule's polar nature its ability to pull molecules apart into their ionized subcomponents.

Conductivity is measured by finding the resulting voltage when positive and negative electrodes are placed in a solution and an alternating current is applied. The application of the alternating current causes cation and anions to travel through the solution to their opposing anodes, using the solution as an electrical conductor. With a known current and a measured voltage and using Ohm's Law ($\text{Resistance} = \text{Voltage} / \text{Current}$), the solution's resistance can be calculated. With the solution's resistance, one simply needs to take the inverse to find conductance, and to find conductivity one must simply multiply conductance by the cell constant ($k = d/a$) (Radiometer Analytical 2004). Figure 4 demonstrates the flow of electrons during conductivity measurement.

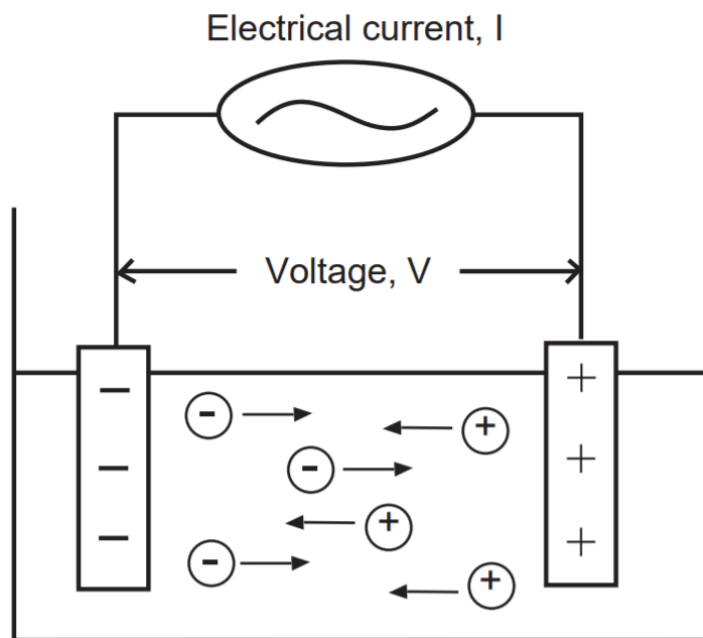

Figure 2-4 Flow of electrons in solution (Radiometer Analytical 2004).

2.4.5 Temperature

Measurements of Temperature has a significant influence on conductivity readings. Conductivity measurements taken with temperature measurements will always be more accurate than conductivity measurements alone. (Ashton, Barron)

The Temperature Coefficient of Variation is the rate that a solution's conductivity increases as temperature rises. The Temperature Coefficient of Variation is expressed as the percentage increase in conductivity for a temperature change of 1°C. Below is a table of measured variation of various solutions. Temperature plays a significant role in conductivity readings because as the temperature rises, the liquid's viscosity lowers, and ions are freer to travel. More freedom for ions to travel is ideal for more conductance. For example, it can be seen in the Table 2-2 that the Ultrapure Water increases its conductance 0.55% with every temperature increase of 0.1°C. (Barron & Ashton 2007)

Table 2-2 Temperature Coefficient of Variation for Common Solutions
 (https://www.camlab.co.uk/originalimages/sitefiles/tech_papers/tempcondmeas.pdf)

Solution	Temperature Coefficient of Variation %/ °C at 25 °C
Ultrapure Water	5.5
NaOH 5%	2.01
NaOH 30%	4.50
HCl 5%	1.58
HCl 30%	1.52
KCl 5%	2.01
KCl 20%	1.68
Fresh water	~ 2.0

2.5 Example Projects

2.5.1 Current Conductivity Meter Model

The EC210 Compact Conductivity/TDS Meter by ExTech is a current conductivity probe available on the market. The probe is capable of measuring conductivity, total dissolved solids, and temperature. The conductivity measurement also has a correction feature. The probe is powered by a 9-Volt battery and has an automatic shut-off mechanism after a set time period. The measurable conductivity range is a low reading 2000 micro siemens per centimeter and a high reading of 100 milli siemens per centimeter. The meter must first be calibrated using a standard solution with a known conductivity ((EXTECH 2019).

2.5.2 Past ENGR 215 Project Involving Education in Science

The reviewed design project consisted of making a mechanism that can help provide an audience a better understanding of how waveforms as interest in the area. The team (Team Outback) pendulum model to focus on visual stimulus for learning. designed for hands-on learning, in that a user could push the initial piece of the pendulum and then watch as the mechanism moved in a waveform pattern. Since this mechanism was meant to be used for teaching, considerations into its design included functionality, storability, portability, safety, durability, educational value, and inspirational value. How well the prototype would teach and engage users was considered just as key as it's functionality. Many pendulum types and models were considered before the team chose their type, with functionality, durability, and safety being the key determining factor in the team's decision. These pendulums contained a line LED lights, and for safety the circuitry was surrounded by heat shrink to avoid fire hazards. The lights were arranged in parallel and placed in series with 150-ohm resistors. Time was taken to know the voltage drop and the current through each light. The pendulum was also designed to be collapsible and fit in a box for easy portability. (Team Outback 2017)

2.5.3 Probes

There are two types of conductivity sensors. On the left is a Contacting Conductivity Sensor. This type of probe is ideal for use in pure and ultrapure water applications. This is because they are highly sensitive to ions present, providing the highest accuracy for low conductivity measurements. On the right is an Inductive Conductivity Sensors. This type of probe is much more versatile and is better used for measurements in dirty, corrosive, or high conductive solutions. Although this type of probe is not as sensitive or accurate, it is much more durable than its counterpart. (Yokogawa)



Figure 2-5 Contact Conductivity Sensor (left) and Inductive Conductivity Sensor (right)
(<https://www.yokogawa.com/us/solutions/products-platforms/process-analyzers/liquid-analyzers/conductivity-sensors/>)

3 Alternative Solutions

3.1 Introduction

Six solutions have been proposed as a prototype for the Conductivity Probe. Each alternative was developed based on meeting the specifications provided by Dr. Morago for serving the needs of the Arcata High School science classrooms.

3.2 Brainstorming

Team Current Wave met for a 2-hour period to brainstorm before coming up with a set of alternative solutions. Each member arrived at the brainstorming session with two partially formed design ideas. The team then went through each proposed design one at a time and provided input to address concerns and provide potential improvement. Time was then taken to brainstorm attributes to the design based on individual sections: display type, shape, probe type, and body material. Once a list was made for each of these categories, the team considered various combinations for possible design solutions.

3.3 Alternative Solutions

After completion of the brainstorming session, each member sketched a handful of alternative solutions based on the ideas and input of team members. The members of the team then collaborated and decided on six alternative solutions. These solutions are weighted based on criteria, and one solution will be chosen for the final design.

These are the lists of solutions:

1. Conductivity Canon
2. The Lighthouse
3. Colored Chest
4. Light Chest
5. The Egg
6. Spectrums

3.3.1 Conductivity Cannon

The Conductivity Cannon houses a light in a plastic body that is in the form of a cannon and about one foot in length. It rests on a wooden stand with four legs. Inside the mouth of the cannon is a low-voltage dimmer lightbulb. The power source to the probe is a 9-volt wall wart and a fuse, with the electric cord connected at the base of the cannon near the stand. The fuse protects against electric shocks, shutting off the circuit when the current reaches to high of a value. The hot wire from the power cord runs to the top of the cannon into the cord mimicking a cannon fuse. At the end of the fuse cord is the conductivity electrodes. The incoming hot wire connects to one of the probes, and another wire connects the second electrode to the lightbulb. The second wire from the power cord also runs to the lightbulb base. When the electrodes are inserted into a solution with a high enough salinity, the electric circuit is connected, and the lightbulb illuminates the mouth of the cannon, as shown in Figure 3-1. This Conductivity Cannon serves as an effective qualitative display and the circuitry is simple to repair. It sits low to the ground, the plastic body is difficult to damage without intention, and the probe is constructible in under \$50.

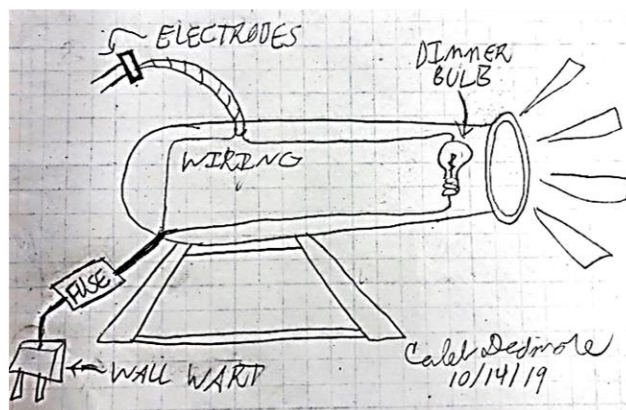

Figure 3-1 The Conductivity Cannon consists of a simple DC closed circuit loop, and has a qualitative display consisting of a low-voltage dimmer lightbulb illuminating its mouth.

3.3.2 The Lighthouse

The Lighthouse is a conductivity meter designed to work similarly to the Arcata High School's previous model, with added aesthetics and safety. The body of The Lighthouse is a wooden tower with a plastic cap, standing at about two feet tall. The top of the tower contains a low-voltage lightbulb. The power source of The Lighthouse consists of a 9-volt wall wart with a fuse to protect against electric shock. The power cord runs into the base of the prototype and is then separated into its two internal wires. One wire connects directly to the lightbulb housing at the top of the tower. The other is connected to a metal conductor plate. The wire at the other end of the lightbulb housing is coiled up and connected to the first electrode on the conductivity electrode. The bottom front face of the prototype has a slot into which the beaker of solution to test is inserted. On the outside wall of The Lighthouse is a lever that can be pulled down, moving the electrodes down towards the beaker. The other electrode on the probe is connected to a wire piece that connects to the metal conductor plate when the probe reaches the beaker solution. If the solution has a high enough salinity concentration, this closes the circuit and the lightbulb at the top of the tower will illuminate The Lighthouse. Having a lever makes it so that the user never has to handle the electrode, ensuring long-term durability.

The front-facing wall of the body is a clear window that increases the education value that it provided, allowing the user to see the connections and workings of the inside of the prototype. The design costs roughly \$50. Safety has been considered by using a fuse, all the circuitry being internalized, and low DC voltage and current. The front window of the tower is removable, allowing easy maintenance. As seen in Figure 3-2, It also adds an aesthetic and inspirational appeal. This factor is particularly geared towards those in the area of Humboldt, in that it takes the form of a lighthouse.

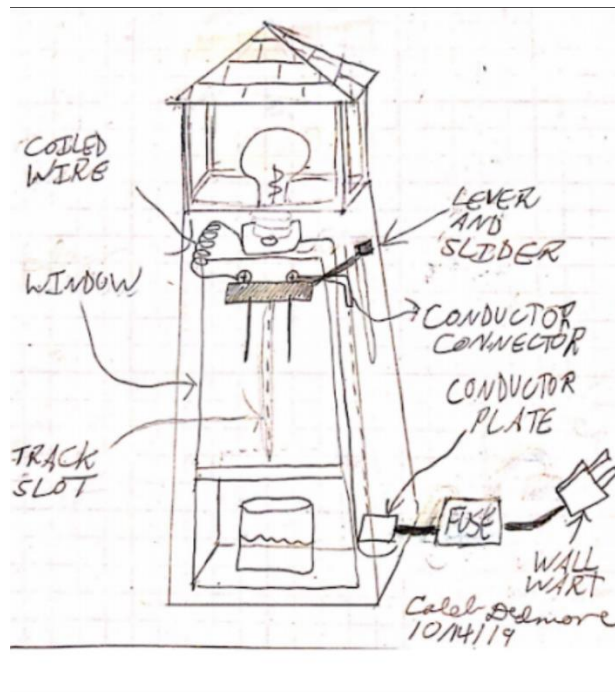

Figure 3-2 The Lighthouse consists of a closed DC circuit, with a lever so that the user does not touch any of the electronics. Upon pulling the lever and inserting the probe into a high salinity solution, the top of the tower is illuminated by a low-voltage

3.3.3 Colored Chest

The Colored Chest uses commercially available wood that can easily be bought in local stores or online. The wood is held together with wood glue and iron slabs shown in Figure 3-3. The wooden box contains an assortment of lights that range from red to violet. The chest has a probe that can be pushed into different solutions. If a solution has a high conductivity, more of a violet/blue color is displayed. A small amount of conductivity displays a more red color, and a gold color is displayed for middle ground conductivities. This assortment of colors is done via an assortment of colored LED light bulbs. The probe piece connects to a microcontroller, which relays which LED bulbs to turn on based on the solution's voltage reading. The chest gives qualitative data on a basis of low, mid, and high conductivity. It is roughly a cubic foot in size, meeting the client's specifications. Figure 3-3 displays an isometric view of the Colored Chest.

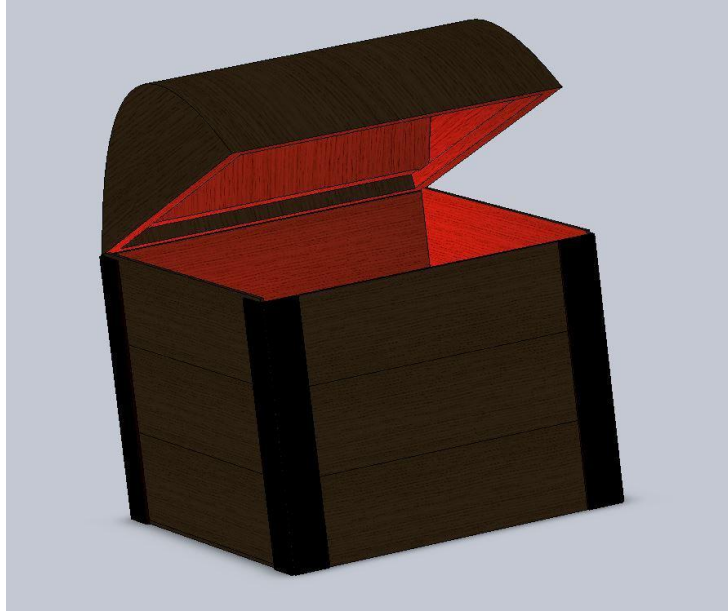

Figure 3-3 The Colored Chest is shown with a red glow, indicating a solution with low conductivity (design by Marco Gudino)

3.3.4 Light Chest

The Light Chest relies on standard white Light Emitting Diodes (LEDs). This body of this design, like the Colored Chest, is made out of commercially available wood. The Light Chest relies on a circuit that is closed into a completed loop when two prongs are dipped into a liquid with a minimum level of conductive properties. The lights shine brighter if the conductivity is higher in the solution, and dimmer if the conductivity is lower. This design does not require a microcontroller or code, as the same bulbs are used for all concentrations of conductivity in a solution. Figure 3-4 displays an isometric view of the Light Chest design and displays where the slots for holding the beakers in place are located.

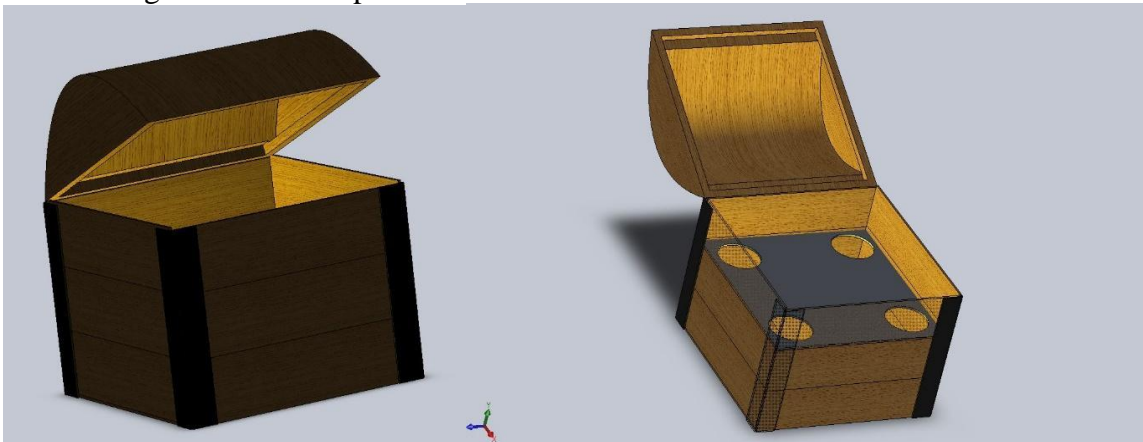

Figure 3-4 The Light Chest is a modification of the Colored Chest, using dimmer lightbulbs in a parallel circuit rather than a microcontroller and colored LEDs (Design by Marco Gudino)

3.3.5 The Egg

The Egg is a conductivity meter designed to create an appealing visual display. There is an internal wire frame that supports horizontally stacked strips of LED bulbs. These lights are then

encased in a semi-transparent plastic shell, allowing for the egg to glow upon illumination of the bulbs. This plastic shell also protects the individual bulbs to ensure durability of the product. A conductive solution is placed in a cavity in the front center of The Egg, after which the probe lever is shifted to the “down” position. This motion inserts the electrodes into the solution. If the solution has a high enough conductivity, this allows the circuitry to become a closed loop, lighting up the LEDs and illuminating The Egg. The LED light strips are connected in parallel, allowing for an even lighting throughout each strip. The design is shown in Figure 3-5.

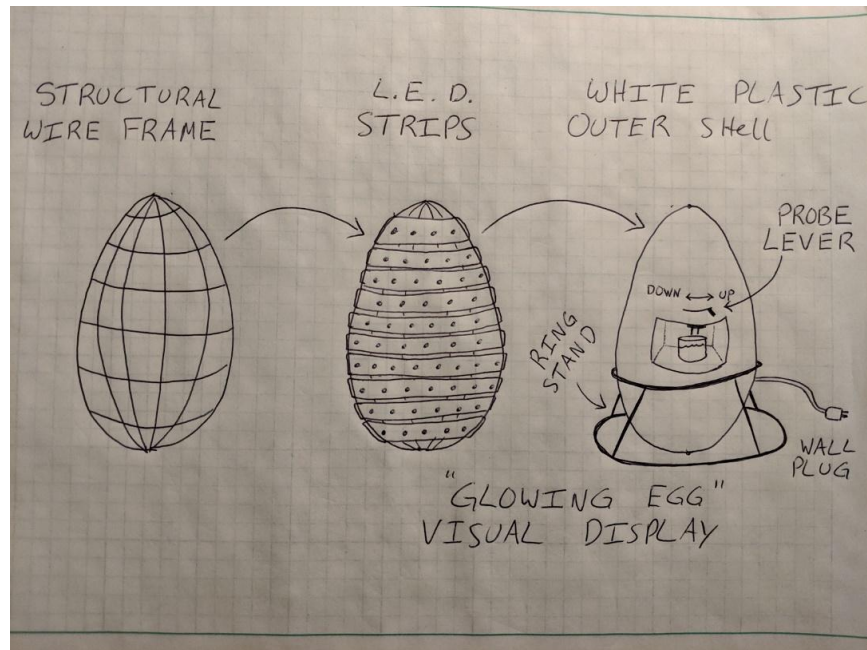

Figure 3-5 The Egg stands at about 15 inches in height, with a casing to protect the bulbs from damage during use (Design by Leith Butler)

3.3.6 Spectrums

The body of the Spectrums is a hollow rectangular box with a lid. This allows for easy storability of the prototype. There is a screw-in ring stand and ring into which a cylindrical beaker sits. Over the beaker is an attachable lid containing the two probe electrodes. Upon closing of the lid the electrodes are inserted into the beaker. If the solution in the beaker is conductive enough, current will be able to pass through and the light displays are activated. The visual displays and circuitry are secured to the top surface on the inside of the lid. This body and container is built to match two different display designs.

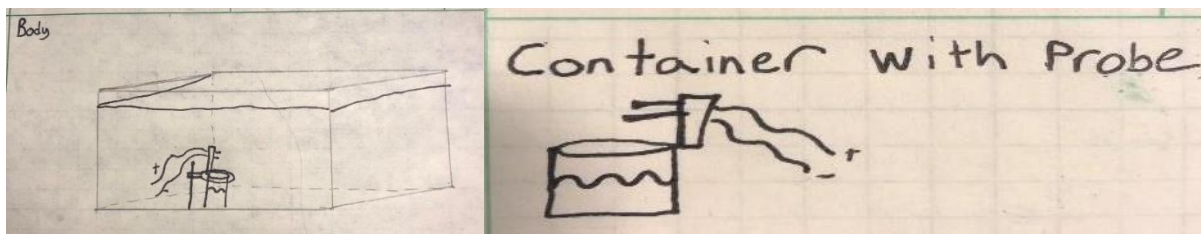

Figure 3-6 Body and container variant of Spectrums of Conductivity (Design by Kush Rawal)

3.3.6.1 Spectrums Meter Display

The Spectrums Meter Display has six colored lights in ascending order from lowest to highest light wave intensity. A solution with a low conductivity lights up only the red light at the bottom of the display. Solutions with increasingly higher concentrations consecutively light up the next light on the display. A max conductivity reading lights up all of the six colored lights. Next to each meter is a display that reads the conductance of the solution in Siemens per meter. The two displays are controlled using a microcontroller, which reads the voltage of the solution and lights up the display using a logic gate.

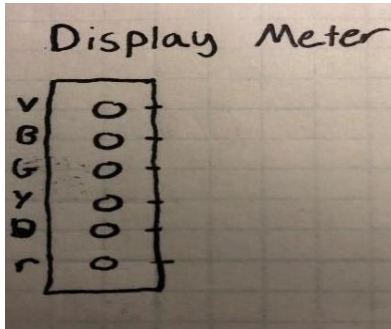

Figure 3-7 A meter display is the first of two six-colored light bars for Spectrums (Design by Kush Rawal)

3.3.6.2 Spectrums Rainbow Display

This Spectrum conductivity meter uses the same circuitry principles as the Spectrums Meter Display, only with a different visual layout. It lights up the color arcs in accordance with the conductivity of the solution, illuminating additional arcs as conductivity increases. Each arc of the Spectrums Rainbow Display has a light source at its base, and is lit up through the use of fiber-optics material.

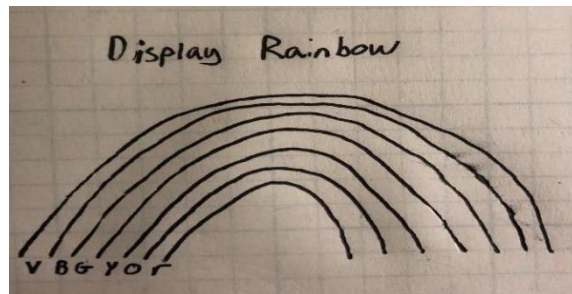

Figure 3-8 The Spectrum's Rainbow Display is an alternative to the Spectrums Meter Display, using fiber-optics to generate a rainbow visual to the user. (Design by Kush Rawal)

4. Decision

4.1 Introduction

Section 4 explains how Team Current Wave finalized the final prototype from the list of alternative solutions in Section 3. The final decision was concluded from Current Wave's and Dr. Morago's criteria, specifications, and a Delphi Matrix.

4.2 Criteria

Section 4.2 lists the criteria used to determine the final design. The list of criteria is below.

Feasibility: how possible the design is to build

Safety: how safe the design is for high school-age children to use.

Durability: how well the design will theoretically hold up over years of use in a high school lab environment.

Level of Engagement: the level in which the design might capture and hold a student's or user's attention.

Ease of Repair: how easy and intuitive it is for the client to repair any components that may break over the course of the design's lifetime.

Cost: how much it would cost to manufacture 4 copies of the design, and the estimation of how much it would cost to repair broken components over the design's lifetime.

Aesthetics: how visually pleasing the design is to the user

Educational Value: The design's potential to teach students about the subject matter.

Inspirational Value: the design's potential to inspire students to continue learning about science.

4.3 Solutions

Section 4.3 simply lists all the alternative solutions. Each was graded by the criteria. This is the list of all the alternative solutions described in Section 3.3.

- Conductivity Cannon
- The Lighthouse
- Colored Chest
- Light Chest
- The Egg
- Spectrums

4.4 Decision Process

The criteria were weighted by the importance. Table 4-2 shows a list of the criteria and their weights used to justify the determination of the final design solution.

Table 4-1 Weighted Criteria used for Delphi Matrix

Criteria	Weight
Safety	10
Level of Engagement	9
Ease of Repair	8
Durability	7
Cost	7
Feasibility	7
Educational Value	5
Aesthetic	4
Inspirational Value	4

A Delphi Matrix was used to identify the top two designs out of the list of alternatives. Each criterion was given a weight from 1 to 10 based on its importance to the overall design goal. Each design alternative was then separated into columns. As shown in Figure 4-1, each criterion was then scored on a scale of 1 to 100 for each design. These criteria were then summed to provide a total score for each of the alternative designs. Each team member of Current Wave filled out a Delphi Model individually, after which scores were discussed as a group. The Lighthouse was determined to have the highest score because it best meeting the criteria for the problem solution. The Light Chest came in second and was kept in consideration as a tie until discussed with the client. The Light Chest was not chosen because it would be difficult for the students to see what is occurring inside the box from afar. Ultimately, the clear front of The Lighthouse caused it to be chosen. Figure 4-1 shows the averaged values of the four Delphi Matrices made by each of the four members of Current Wave.

Table 4-2 Delphi Matrix of Each Alternative Design (made by Caleb Dedmore)

Criteria		Solutions					
List	Weight	Conductivity Cannon	The Lighthouse	Colored Chest	Light Chest	The Egg	Spectrums
Safety	10	59 590	93 930	72 720	74 740	73 730	78 780
Durability	7	76 532	81 567	83 581	83 581	73 511	73 511
Level of Engagement	9	75 675	93 837	81 729	80 720	84 756	78 702
Ease of Repair	8	76 608	81 648	74 592	86 688	48 384	51 408
Cost	7	81 567	81 567	69 483	80 560	56 392	73 511
Aesthetics	4	80 320	90 360	84 336	79 316	95 380	86 344
Educational Value	5	70 350	83 415	71 355	80 400	70 350	78 390
Inspirational Value	4	63 252	90 360	84 336	83 332	90 360	89 356
Feasability	7	63 441	76 532	70 490	83 581	54 378	56 392
Total		4335	5216	4622	4918	4241	4394

4.5 Decision Justification

The final design choice for the Arcata High School Conductivity Meter is The Lighthouse. This model had the highest scoring on the Delphi Matrix, as shown in Figure 4-2. The Lighthouse was also the safest out of all of the alternative solutions, with a closable cover and lever making the risk of shock almost nonexistent for a user. The design also provides an easily understood qualitative display with an aesthetic appearance. The circuitry setup is simplified compared to some of the other models, indicating that finishing the probes within the timeline is feasible. The Lighthouse's high ratings on the various weighted criteria make it the final design decision for the Conductivity Meter.

5 Specifications

5.1 Introduction

Section 5 is an overview of Team Current Wave's final solution, consisting of 5 subsections: an overview of material tests that were done, a detailed description of the solution, a breakdown of manufacturing and maintenance costs over the life of the product, instructions for implementation, and test results that led to final design specifications.

5.2 Material Testing

Three material tests were done to optimize portions of The Lighthouse Conductivity Meter. The first two tests were corrosivity tests of various metals to determine the best metal to use for probes. The metal that was tested to have the least amount of oxidation was chosen as the material for the two probes on the conductivity meter. The third test carried out was a light bulb test, in which multiple light bulbs of differing voltage and amperage ranges were tested to select the bulb with the best dimming range based on the expected conductance of solutions that The Lighthouse will be used to measure in Six Rivers Charter School lab classes.

5.2.1 Probe Metal Selection: Disc

The first experiment consisted of various metal washers being submerged in a constant molar solution for 30 minutes. This experiment was to test mass reduction of the oxidizing anode after post conduction. Washers were selected because our team assumed the oxidation reaction would be slow and the washers have a high surface area to volume ratio, thus, oxidizing faster. The result proved after 30 minutes; all of the anodes disintegrated with the exception of the galvanized steel which impressively did not experience any mass reduction.

Table 5--1 Results of the oxidation test of various metal discs. A 9.28V DC charge was inputted on two discs of each metal for a duration of 30 minutes while submerged in a 2M NaCl solution to asses mass loss due to oxidation.

Metal type:	Initial Mass (g)	Final Mass (g)	Initial Voltage (V)	Final Voltage (V)	Δ mass (g)	Δ voltage (V)	Visible Oxidation
Galvanized Steel	7.1	7.1	0.69	0.69	0	-	no
Stainless Steel	0.7	0.5	8.56	0.00	-0.2	-8.56	yes
Brass	1.3	0.60	2.01	0.00	-0.7	-2.01	yes
Copper	0.9	0.4	2.29	0.00	-0.3	-2.29	yes
Aluminum	<0.1	<0.1	1.86	0.00	N/A	-1.86	yes

5.2.2 Probe Metal Selection: Rod

The second experiment was a direct continuation of the first corrosivity experiment. Instead of washer, various metal screws were chosen because rods have a closer surface area to volume ratio resulting in a slower oxidation rate. A voltmeter was also attached to the circuit to see if there was a voltage change going to the light pre and post conduction. After being submerged for thirty minutes, every metal sample experienced a mass reduction and voltage change with the exception of galvanized steel. The second experiment solidified the final design choice to use galvanized steel as the electrode material.

Table 5-2 Results of the oxidation test of various metal rods. A 9.28V DC charge was inputted on two discs of each metal for a duration of 30 minutes while submerged in a 2M NaCl solution to assess mass loss of the metal rods due to oxidation.

Metal type:	Initial Mass (g)	Final Mass (g)	Initial Voltage (V)	Final Voltage (V)	Δ mass (g)	Δ voltage (V)	Visible Oxidation
Galvanized Steel	23.1	23.1	1.38	1.38	0.0	-	no
Stainless Steel	16.7	16.7	1.50	1.70	0.0	-0.2	yes
Zinc	18.3	18.2	2.36	2.04	-0.1	0.32	yes
Brass	7.0	7.0	2.01	1.82	0.0	0.19	yes
Bronze	13.8	13.5	2.29	2.38	-0.3	-0.09	yes
Nickel	8.2	8.0	2.08	1.98	-0.2	0.1	yes
Aluminum	1.8	1.6	1.86	1.61	-0.2	0.25	yes

5.2.3 Light Bulb Selection

Six various light bulbs were tested for their dimming range to select the best bulb for The Lighthouse. Based on client feedback and past labs done by Six Rivers Charter School, it was assumed that solutions of ionic molarities between 0.1M and 3.0M were most likely to be measured by the conductivity probe. Each of the six bulbs was tested in the probe circuitry on 0.1, 0.5, 1.0, and 3.0M NaCl solutions. The results are shown in Table 5-3.

Table 5-3 Data of recorded during the testing of 6 different light bulbs under various concentrations of NaCl

Light Bulb	Molarity (Moles NaCl/Liter)	Activation (Yes/No)	Lumen Range (constant/increasing)	Brightness (Trend/Quality)	Notes:
3.0 V 0.30 A	0.1	Yes	constant	dim/ orangish	Choice #2: This light works well for the conductance range, but is apt to blowing out at higher ionic concentrations.
3.0 V 0.30 A	0.5	Yes	constant	bright	
3.0 V 0.30 A	1.0	Yes	constant	brighter (almost hurts eyes)	
3.0 V 0.30 A	3.0	Yes	constant	bright (only slightly brighter than at 1M)	
3.8 V 0.20 A	0.1	Yes	constant	very dim	Choice #1: This light works well with a ping pong ball as a cover, and does not blow out at higher solution concentrations
3.8 V 0.20 A	0.5	Yes	constant	brighter	
3.8 V 0.20 A	1.0	Yes	constant	brighter (slightly hurts eyes)	
3.8 V 0.20 A	3.0	Yes	constant	bright (only slightly brighter than at 1M)	
5.0 V 0.02 A	0.1	Yes	constant	dim/ orange	This light does not reach a high enough luminosity for the expected conductance range
5.0 V 0.02 A	0.5	Yes	constant	brighter, still orange	
5.0 V 0.02 A	1.0	Yes	constant	brighter, but still not very bright	
5.0 V 0.02 A	3.0	Yes	constant	still not ideal level of brightness	
5.0 V 0.06 A	0.1	Yes	constant	dim	Choice #3: not as easy to tell difference between brightness for 1 and 3 M for this bulb
5.0 V 0.06 A	0.5	Yes	constant	brighter	
5.0 V 0.06 A	1.0	Yes	constant	brighter	
5.0 V 0.06 A	3.0	Yes	constant	moderately bright	
5.0 V 0.12 A	0.1	Yes	constant	dim	This bulb has a good dimming range, but does not get as bright as other bulb options
5.0 V 0.12 A	0.5	Yes	constant	brighter	
5.0 V 0.12 A	1.0	Yes	constant	brighter	
5.0 V 0.12 A	3.0	Yes	constant	brighter	
6.3 V 0.20 A	0.1	Yes	constant	dim/ orangish	There is not a large change in brightness, not a very appealing color, doesn't get very bright
6.3 V 0.20 A	0.5	Yes	constant	dim/ orangish	
6.3 V 0.20 A	1.0	Yes	constant	dim/ orangish	
6.3 V 0.20 A	3.0	Yes	constant	dim/ orangish	

The 3.8V, 0.20A light bulb was chosen for The Lighthouse, having had the best dimming range without being apt to blowing out at higher ionic concentrations. A ping pong ball was chosen as a cover to minimize the impact of the bulb's brightness on a user's eyes.

5.3 Description of Solution

The Lighthouse Conductivity Meter is a probe used for measuring the conductivity of a liquid solution. The design consists of a wooden body with a plastic rooftop housing. Inside is a probe block that slides along a dowel to lower two probes into a solution. The probes are connected to an electrical circuit that lights a lightbulb at the top of The Lighthouse if the solution has a readable conductivity. The bulb increases in brightness with increasing conductivity.

5.3.1 Wooden Body

The body of The Lighthouse is built out of $\frac{1}{2}$ " plywood. There are three walls, a base, and a roof. The walls are 12" tall trapezoidal shapes. The back wall has a 4" width on the top and 7" width on the bottom. The other two walls have a 3.5" width and a 6.5" width on the bottom. Since the tower leans in, the tops and bottoms of the wall pieces were cut at a 7.2-degree angle. The base and top pieces are trapezoidal pyramids also cut at 7 degrees, with the base having dimensions of 6" x 6.5" and the roof having dimensions of 4" x 3.5". The roof has a 1" hole drilled into the center for the light bulb housing. All the wooden cuts were sanded down and pre-drilled before painting. On the front of The Lighthouse, a piece of plexiglass was cut and smoothed down to fit on the upper 5.5" inches of the open wall, serving as a window to view the inner components of the design. The window was screwed in at its four corners using screws with gaskets so as to avoid cracking when overtightened. The bottom 6.5" of the front side of The Lighthouse is left open for the insertion of solution beakers onto the base.

Several prototypes of the wooden body were made to determine a proper size for students' use. The final one, was sturdy and had a wide base that makes it difficult to get hands jammed in. Figure 5-1 shows all three different lighthouses made.

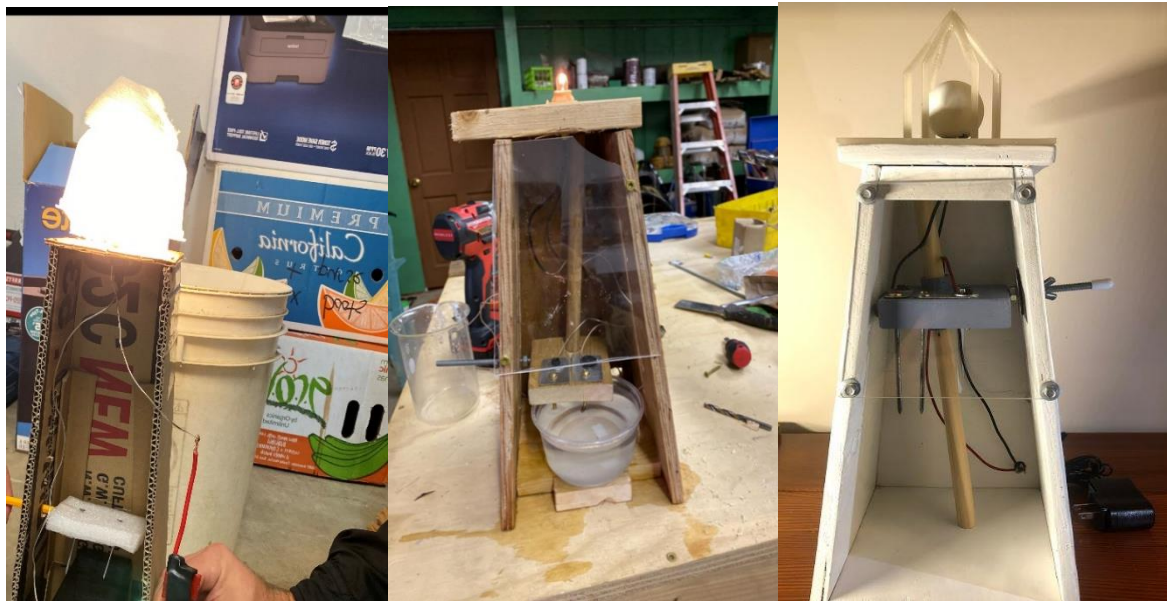

Figure 5.-1 Evolution of Lighthouse Bodies

5.3.2 Rooftop Housing

The rooftop housing is made of PLA material. It was 3D printed and fixed to the board of wood on top of the lighthouse. There are two locations on the rooftop housing that is screwed into the board. This allows the rooftop housing to be removed easily. The housing is made to guard the lightbulb in case the lighthouse is dropped.

Several rooftops were designed and printed to make sure it housed the light correctly. Figure 5-2 shows three prototypes. The first one was too complex, took too long to print, delicate and was determined to be too difficult to house within the lighthouse body. The second was too small and did not fit the Ping-Pong ball that surrounds the lightbulb. The final one, was able to fit the lightbulb and Ping-Pong ball, had a low printing time, and was easy to screw onto the lighthouse body,

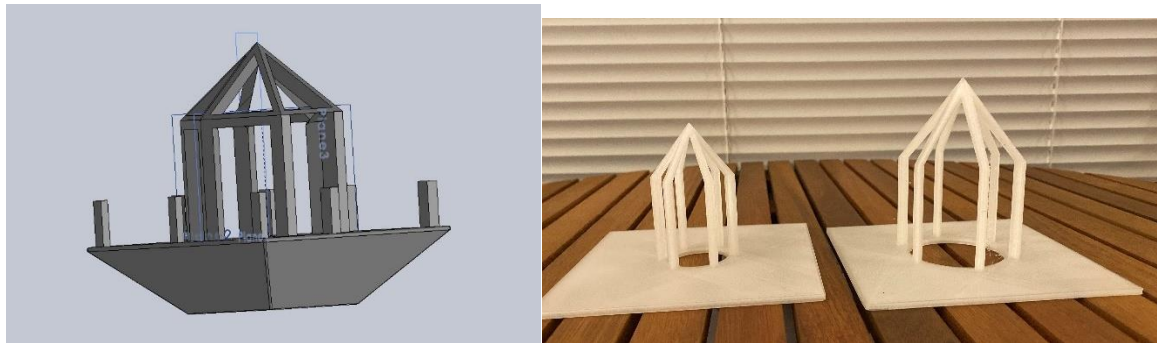

Figure 5.-2Rooftop Housing Screwed on Lighthouse

5.3.3 Probe Block and Slider

The aptly named Probe Block is the body -- constructed of a block of wood -- in which the probes themselves are attached. This block of wood is in the body of The Lighthouse and has two pre-drilled holes -- about an inch apart -- where the two probes (galvanized-steel nails) are inserted. These probes are in contact with small plates of sheet metal which are attached to the Probe Block with the use of wood screws. These screws are tightened over a washer, fastening the wiring to the probes and creating a closed circuit once the probes come into contact with a conductive solution.

A third pre-drilled hole is where the Probe Block is attached to the body of the lighthouse via a vertical wooden dowel which the Probe Block slides up and down. This third Probe Block hole is lined with a 2" section of PVC tubing to reduce friction between Probe Block and dowel.

Inserted horizontally into the Probe Block is the Slider handle, a 1/4" threaded steel rod that extends to the outside of the lighthouse body via a vertical slot on the right side of the wooden body. Threaded onto the Slider handle is a wingnut and a washer that, when tightened against the body of the lighthouse, secures the Probe Block at the desired height. Figure 5-3 shows the wingnut, washer and slider handle.



Figure 5.-3 Side of lighthouse. Shows wingnut, washer, and slider handle

5.3.4 Electrical Circuit

The electrical circuit consists of copper wire, a 3.8 V 0.20A light and two galvanized steel probes. The light is secured at the top of the lighthouse, under the roof, screwed into a base. The negative wire of the light is secured to a 9 Volt power source negative terminal. The positive wire is then attached to the first probe. If there is a conductive solution beneath, the charge will jump to the other probe and continue back up to the positive terminal where the loop is now completed. The schematic of the circuit is shown in Figure 5-4.

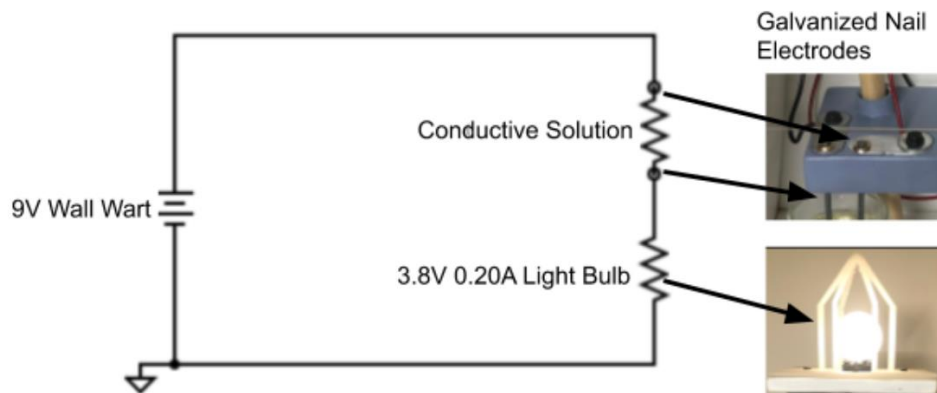

Figure 5.-4 Schematic of Lighthouse

5.4 Costs

The analysis of the costs was separated into three parts. The three sections are design costs, materials costs, and maintenance costs.

5.4.1 Design Costs

The Design costs totals the number of hours Current Wave spent on the project. Table 5-1 shows the number of hours spent on each section of the project. Table 5-2 shows the percentage of work spent on each section of the project. Both tables show the majority of time was spent on Section 5.

Table 5-4. Hours Spent on each section

Section	Hours
1	12
2	50
3	37
4	18
5	60

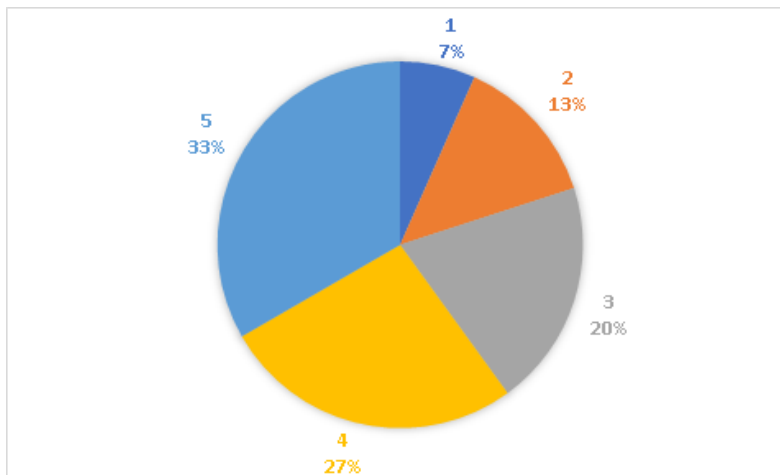

Figure 5.-5 Referencing Table 5-4 -- Percentages of time spent on each section

5.4.2 Materials Costs

Materials costs totals all the materials that were purchased for this project. Table 5-5 shows each part, costs, tax, quantity, shipping costs, and totals of all the materials.

Table 5-5. Costs of Materials including shipping and taxes

Part	Cost	Tax	Quantity	Total
Bolt	\$0.65	\$0.06	2	\$1.42
Washer	\$0.23	\$0.02	4	\$1.00
Nut	\$0.25	\$0.02	2	\$0.54
Acrylic Knife	\$7.99	\$0.68	1	\$8.67
Acrylics Sheet	\$14.99	\$1.40	1	\$16.39
Light Bulb	\$4.99	\$0.40	1	\$5.39
2.1 x 5.5 Wood	\$1.50	\$0.11	1	\$1.61
Dowel	\$3.99	\$0.30	1	\$4.29
Allthread rod	\$2.89	\$0.20	1	\$3.09
Aluminum sheet metal	\$8.99	\$0.80	1	\$9.79
Latching Tote	\$11.99	\$1.00	1	\$12.99
1 W LED nightlight	\$5.99	\$0.50	1	\$6.49
Socket Phen	\$5.49	\$0.50	1	\$5.99
Bulk Fasteners	\$0.50	\$0.05	4	\$2.20
Bulk Fasteners	\$0.08	\$0.05	10	\$1.30
				\$81.16

5.4.3 Maintenance Costs

Maintenance on The Lighthouse is expected to be at a minimum. The bulb is expected to last at least 3-5 years, after which a replacement can be plugged into the housing. A pack of ten can be bought for \$5.90. Corrosion is not anticipated to be an issue, particularly with the amount of usage that the probes will get per year. If any corrosion does take place on the probes over time, a new 16 penny galvanized nail can be inserted for the cost of about \$0.10 each. If the probes and the bulb were replaced at most every 3 years, the yearly cost of maintenance would be \$0.33. No other general maintenance costs are expected to be needed for The Lighthouse.

5.5 Instructions for Implementation and Use of Model

Before using The Lighthouse, check to make sure that the probe block and housing is intact and that the electrodes are not in contact with one another. Also make sure to check for any loose or disconnected wires in the body. Also make sure that the probe block is raised to its top position by looking at the lever level on the right side of the body. If the lever is not at the top of the notch, unscrew the wingnut ½ a turn and slide the lever up. Tighten the wingnut when the lever is at the top position. After ensuring that the probe is in good shape, plug The Lighthouse into a wall outlet. To use the probe, simply insert a beaker of solution onto the base on the indicated mark. With the right hand, unscrew the wingnut ½ a turn and slide the lever down until the

electrodes are submersed in the solution. If the solution is conductive, the bulb at the top of the tower will light up, with a brightness correlating to the level of conductivity. When done, raise the lever back to the top position, and remove the beaker from the structure. After probe use, the electrodes need to be cleaned off before placing The Lighthouse back in storage. Unplug the power cord and wipe off the electrodes with a paper towel. Ensure that the probe block is at the top position and that the wingnut is tightened. The power cord can then be wrapped up and inserted into the front of the tower for easy storage.

5.6 Results

Tests of the final design indicate consistent success of completing the circuit when the probes are submerged into solutions of varying levels of conductivity. Repetition tests indicate a slider that can withstand raising and lowering the Probe Block a number of times equivalent to 5 years of field usage. Lightbulb tests indicate Team Current Wave's choice of lightbulb can withstand the equivalent of 5 years of field usage. Probe tests indicate that Team Current Wave's choice of probe material can withstand the equivalent of 1 year of field use before needing to be replaced. Concern over warping of wood due to moisture in the body of the lighthouse drove Team Current Wave into the decision of adding a coating of paint as a means of moderate waterproofing.