

# ASSEMBLY MANUAL OF THE MOBILE FABLAB 1 FOR UKRAINE

Step by step instructions

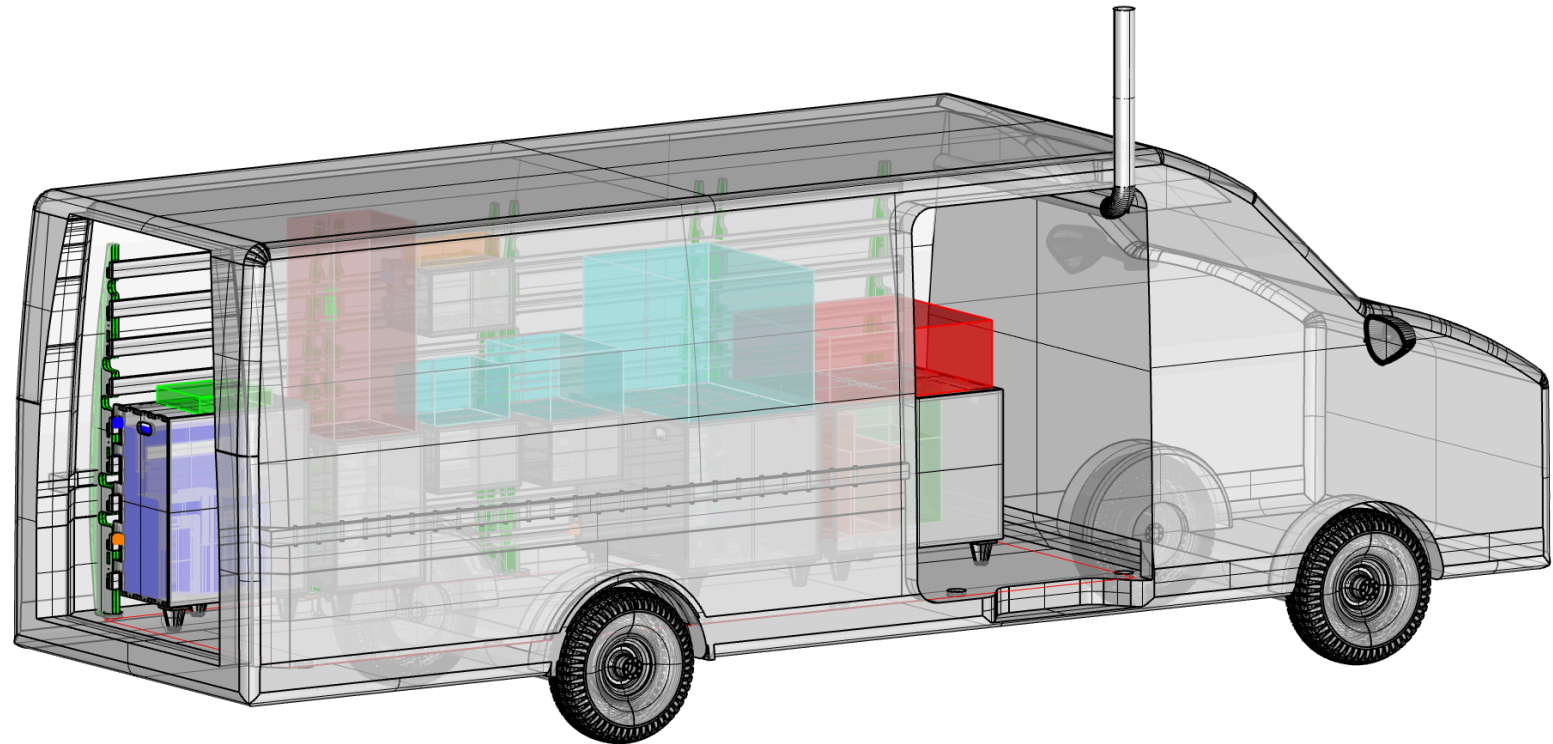

**ASSEMBLY MANUAL BY**  
Marcello Tania

**TEMPLATE MANUAL BY**  
Marc Kohlen  
Liane Sayuri Honda

**HARDWARE BY**  
Marcello Tania, Daniel Asprilla,  
Fabio Lopez Mora, Willheim  
Schütze, Alberto Porri, Gagia Di  
Martino/  
InMachines Ingrassia GmbH



This work is licensed under the Creative Commons Attribution-ShareAlike 4.0 International License.  
To view a copy of this license, visit <http://creativecommons.org/licenses/by-sa/4.0/>

# INDEX

How to use this manual	3
Safety instructions	4
List of tools needed	5
How-to section	6
Step 1.1 Preparing the left pillars 1	9
1.2 Assembling the left pillars 1	10
1.3 Assembling the left pillars 2	11
1.4 Preparing to assembly the left pillars	12
1.5 Assembling the left pillars	13
Step 2.1 Attaching the left bars 1	14
2.2 Attaching the left bars 2	15
Step 3.1 Assembling a box	16
3.2 Assembling a leg	17
3.3 Asttaching the legs	18
3.4 Assembling more boxes	19
Step 4.1 Preparing the right pillars	20
4.2 Preparing to assembly the right pillars	21
4.3 Assembling the right pillars	22
Step 5.1 Attaching the right bars 1	23
5.2 Attaching the right bars 2	24
Step 6.1 Assembling right box	25
6.2 Attaching legs for the right box	26
6.3 Right box installation	27
Step 7.1 Wiring electronics	28
Step 8.1. Celebrate	29
Troubleshooting	30
List of parts	31
Contacts	32

# HOW TO USE THIS MANUAL

This manual provides you a step-by-step guide on how to assemble the Mobile Fab Lab 1. It was developed to be visually instructive, with only necessary text support.

When the step is complex, it is divided into substeps.

Colors are often used to aid and facilitate the identification of parts. If it is necessary to print this manual, make sure to print it in color. However, we highly recommend you to use it digitally to save paper and ink.

Please read the safety instructions before starting the assembly.

Start each step or substep by separating the necessary parts and tools. Then, read the remarks and how-to's related to the step, since they contain important information regarding the assembly. After that you can start assembling by following the visual instructions of the main image and detail bubbles.

Step and substep number and title

Remarks - important text instructions. Read them before starting the step assembly.

How-to - Refers to the How-to section of this manual. It contains assistance and tips.

Assembly progress

Estimated time to complete the step/substep

List of parts necessary for this step/substep

List of tools necessary for this step/substep

The screenshot shows a manual page for 'STEP 1.5 ASSEMBLING THE PILLARS'. At the top, it indicates 'Step 3/33' and '30 min'. The main title is 'STEP 1.5 ASSEMBLING THE PILLARS'. Below the title, there are two substeps: '3x Pillars (Number 2,3 and 4)' and '2x Pillars (Number 1 and 5)'. To the right of these substeps are icons for '40x M7 Lock Nuts' and '40x M7x80 Screw'. Below the substeps, there are icons for '1x Drill', '1x Screw Driver Bit', '3x One Hand Clamp', '1x Small plier or 1x Wrench 5.5'. On the right side, there are two callouts: 'R1. Clamp the pillars.' and 'H1. How to use Lock Nuts? p.'. The main illustration shows a vertical assembly of pillars with a hand drill being used to tighten a screw. A detail bubble shows a close-up of a pillar and a screw. Annotations with lines point to various parts of the manual page.

Detail bubbles contain detailed explanation of a part, or a illustration of a remark.

# SAFETY INSTRUCTIONS

 Read these safety instructions carefully before starting the assembly of the machine.

During the building of Mobile Fab Lab 1, it is mostly required to assemble mechanical parts. However, in some steps, it is required to deal with potentially dangerous situations, due to the involvement of electricity and heavy parts. It is, therefore, really important to follow the safety rules, and to have an adult supervision.

For steps involving **wiring and electricity**, it is highly recommended to read carefully the following instructions before connecting the machine to the electricity power socket (220V) :

- Verify if the cables are not damaged from the packaging, or being damaged during/after the assembly.
- Make sure the cables are firmly connected (check it by pulling it lightly after connecting).
- Make sure cables are correctly connected by double-checking the connections with the wiring diagrams and instructions.
- Make sure there are no short-circuits in the wiring. It is recommended to use a multimeter with the “beep” diode function. It is mostly important, to check if there is not a short-circuit between: Line and Neutral.

For the steps involving the assembly of the **furniture** path, the following safety rules must be observed before starting it:

- Make sure to wear safety shoes due to heavy objects.
- Make sure to have gloves because of wood splinter and if a splinter has penetrated through a body, use medical technique to remove the splinter safely.
- Make sure to wear safety goggles when drilling to protect your eyes.

# LIST OF TOOLS NEEDED

Before starting, check if you have all the necessary tools to avoid unexpected interruptions during the assembly.



**1x** Drill

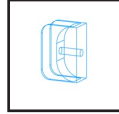

**1x** Template 1



**1x** D7mm Wood Drill Bit

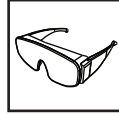

**1x** Plastic Safety Goggles

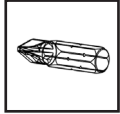

**1x** Screw Driver Bit



**1x** Soft-faced Hammer



**3x** One Hand Clamp

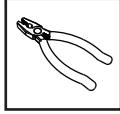

**1x** Small plier

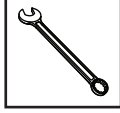

**1x** Wrench

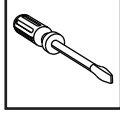

**1x** Screwdriver slotted small

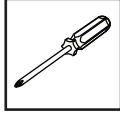

**1x** Screwdriver Philipps 6

# HOW-TO SECTION

Instructions and tips to assist the assembly

## H1. HOW TO USE LOCK NUTS?

Lock Nuts have a nylon cylinder inserted in them which prevents them from getting loose. The nylon cylinder is always coloured so it's easy to recognise which side it is in.

The Lock Nut can be attached onto screws in only one direction i.e. the nylon needs to point away from the screw head.

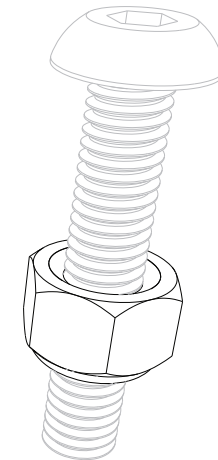
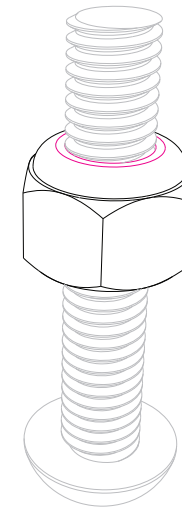
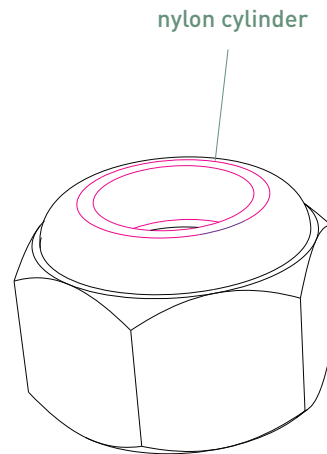

## H2. HOW TO USE SOFT HAMMER?

Soft faced hammer is intended to not damage surface of the work.

First align the objects that you want to connect them together.

Large surface might be needed in case you large object to be assembled, so use a scrap wood and hammer the surface of the scarp wood to get a larger surface area.

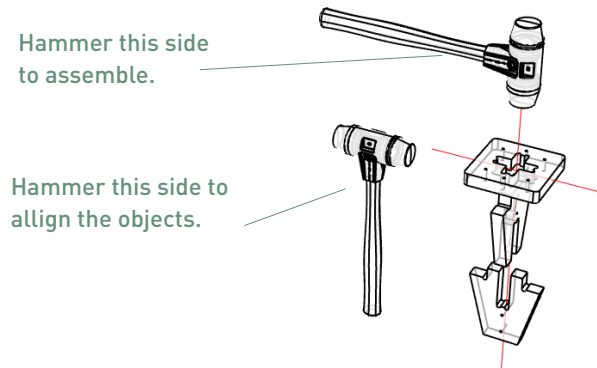

# H3. HOW TO USE HAND CLAMP?

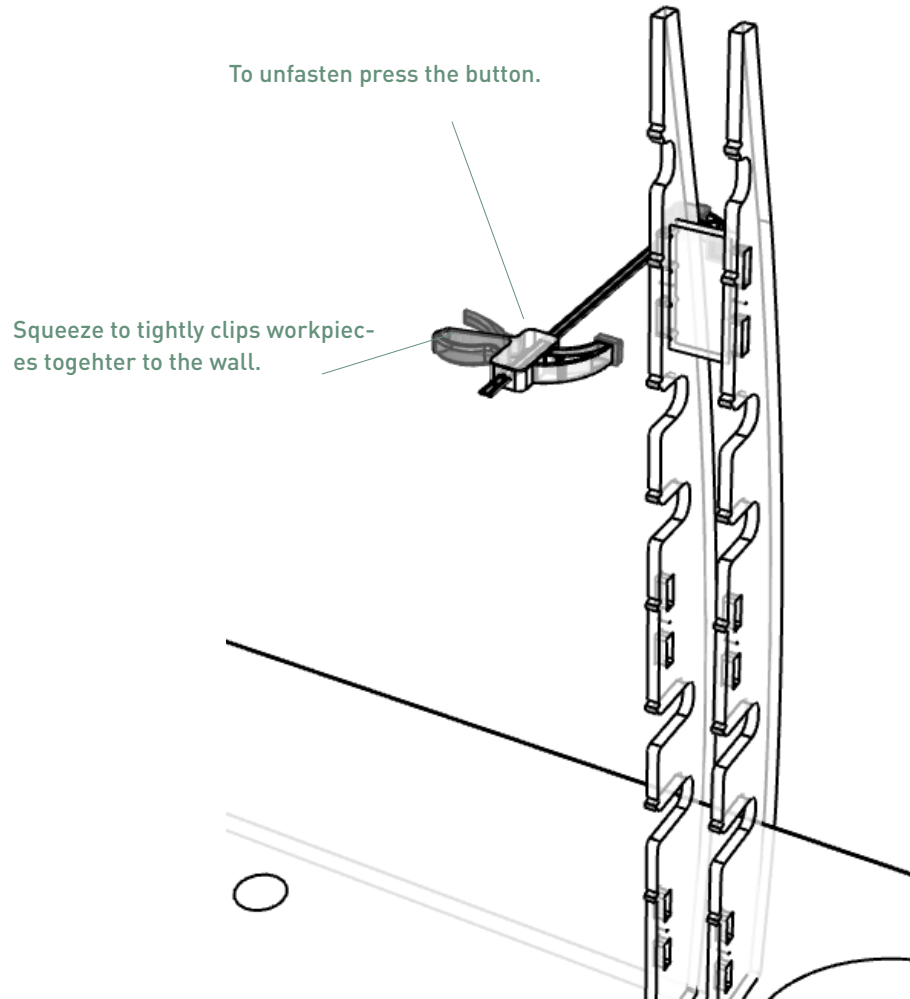

One handed bar clamp is used for holding the piece tightly. Allighn the work piece before clamping and use more than one clamp to hold the work piece properly. Then, adjust the bars to the width to hold the pieces together.

# ARE YOU READY?

Let's start!

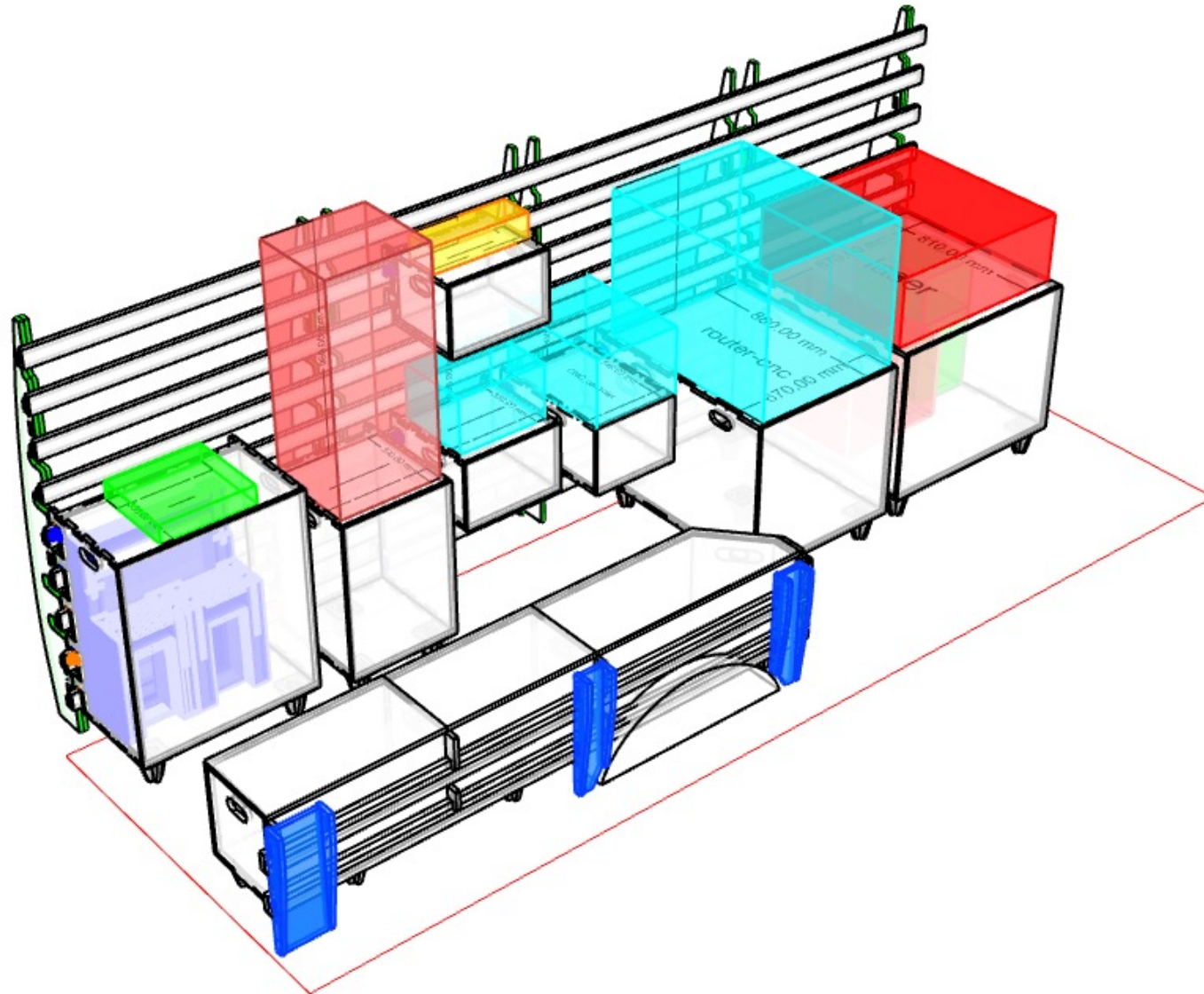

# STEP 1.1 PREPARING THE LEFT PILLARS 1

Step 1/19

🕒 110 min

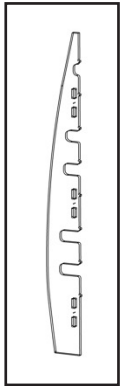

**8x** Long Pillars  
**2x** Short Pillars



- R1.** Use Template 1 to locate the drill point and make sure the template 1 is perpendicular to the pillars.
- R2.** Wear safety goggles to protect your eyes while drilling.
- R3.** Repeat the preparation for pillars number 1,2,3,4 and 5, look page 10.

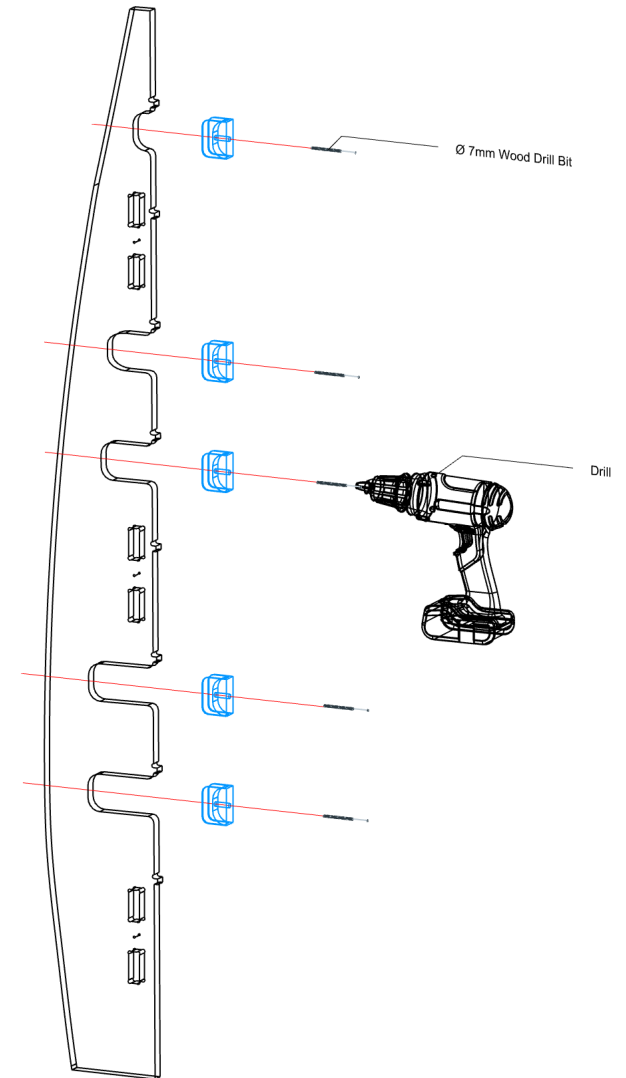

**1x** Drill

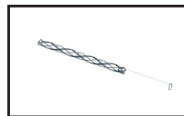

**1x** D7mm Wood Drill Bit

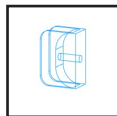

**1x** Template 1

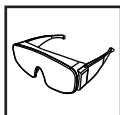

**1x** Plastic Safety Goggles

# STEP 1.2 ASSEMBLING THE LEFT PILLARS 1

Step 2/19

🕒 90 min

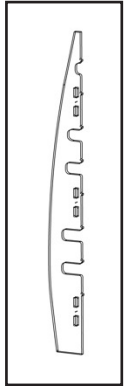

**4x** Long Pillars  
**2x** Short Pillars

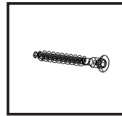

**12x** M7x20 Wood Screw



**R4.** Pay attention to assemble them in the correct position between long and short pillars.

**R5.** Build pillars number 2,3 and 4.

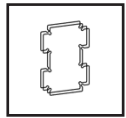

**9x** Pillar Attachments

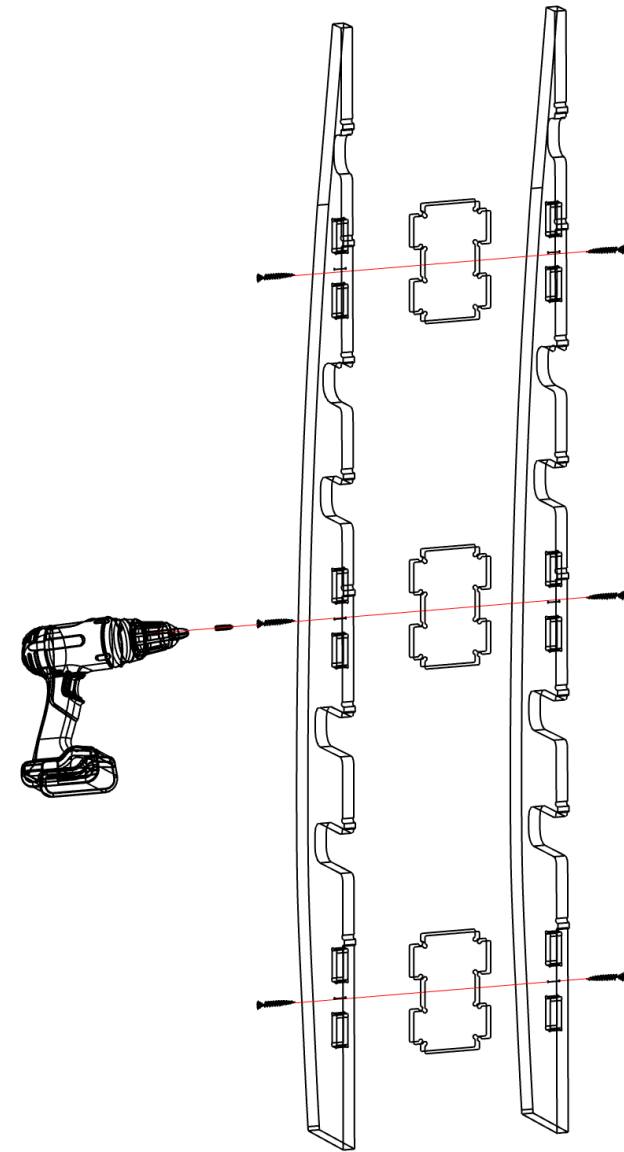
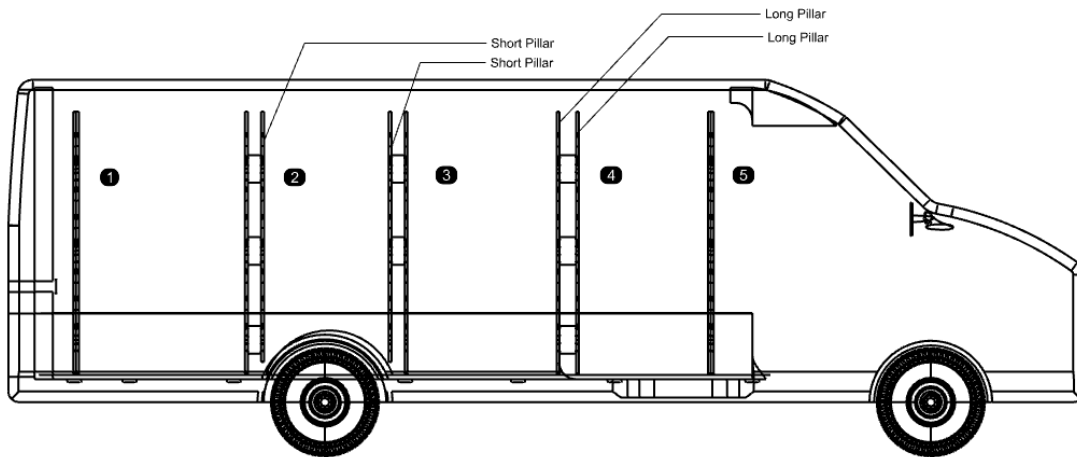

**1x** Drill

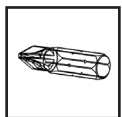

**1x** Screw Driver Bit



**1x** Soft-faced Hammer

# STEP 1.3 ASSEMBLING THE PILLARS 2

Step 3/19

🕒 30 min

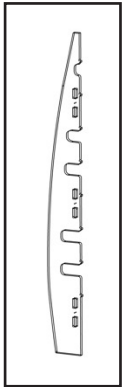

**4x** Long Pillars



**R6.** Build pillars number 1 and 5.



**H2.** How to use the soft hammer?

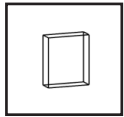

**12x** Wood Blocks

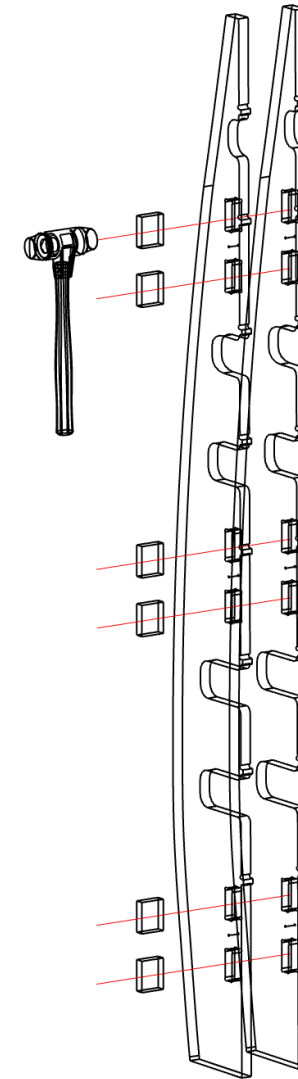
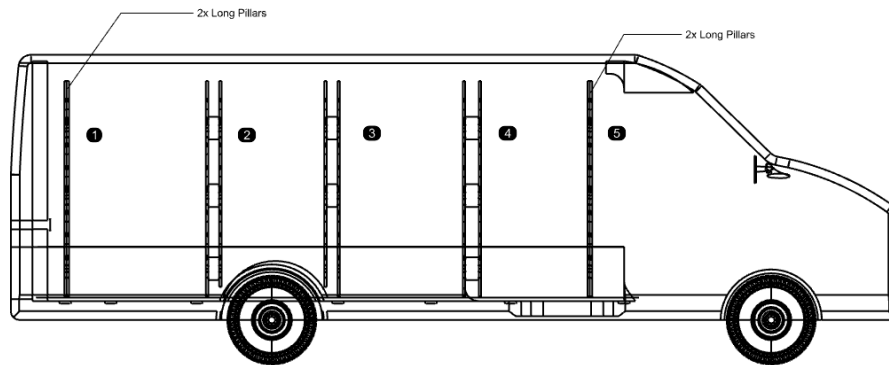

**1x** Soft-faced Hammer

# STEP 1.4 PREPARING TO ASSEMBLY

Step 4/19

🕒 130 min

## THE LEFT PILLARS

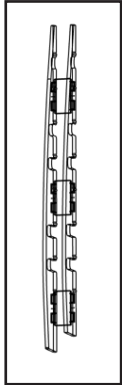

**3x** Pillars (Number 2,3 and 4)



**R7.** Clamp the pillars.

**R8.** Prepare all the pillars number 1,2,3,4 and 5.



**H1.** How to use one hand clamp?

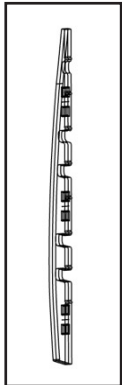

**2x** Pillars (Number 1 and 5)

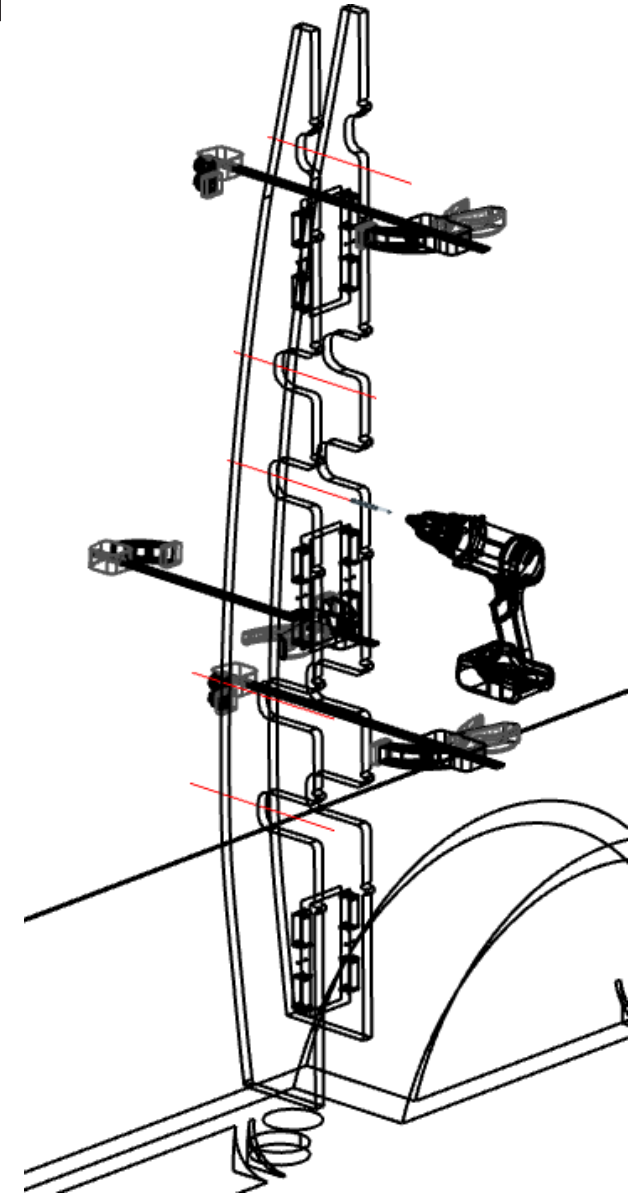

**1x** Drill

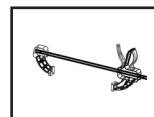

**3x** One Hand Clamp

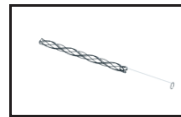

**1x** D7mm Wood Drill Bit

# STEP 1.5 ASSEMBLING THE LEFT PILLARS

Step 5/19

🕒 130 min

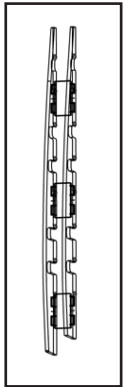

**3x** Pillars (Number 2,3 and 4)

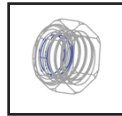

**40x** M7 Lock Nuts



**R9.** Clamp the pillars.  
**R10.** Assembly all the pillars number 1,2,3,4 and 5.

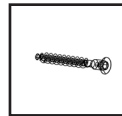

**40x** M7x80 Screw



**H1.** How to use Lock Nuts?

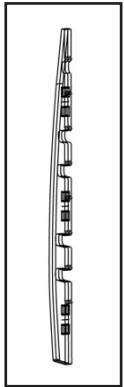

**2x** Pillars (Number 1 and 5)

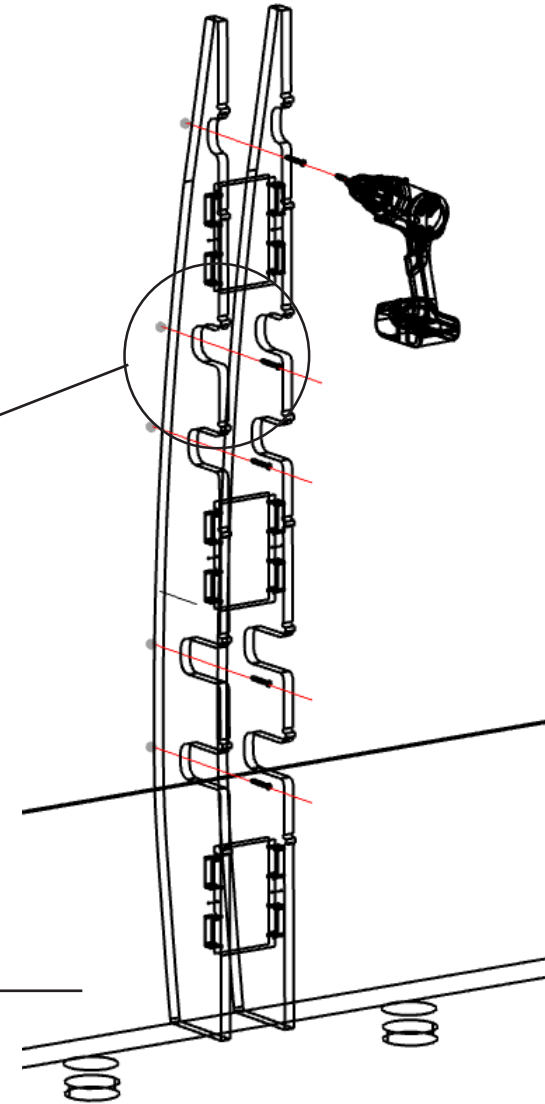
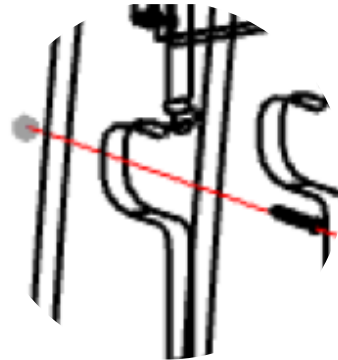

**1x** Drill

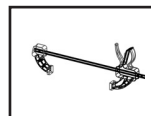

**3x** One Hand Clamp

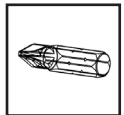

**1x** Screw Driver Bit

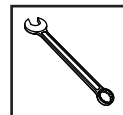
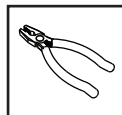

**1x** Small plier **or**  
**1x** Wrench

# STEP 2.1 ATTACHING THE LEFT BARS 1

Step 6/19 ⌚ 90 min

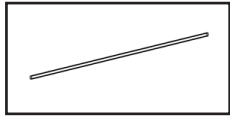

**9x** 24x44x4235 Bars



**R11.** Clamp the bars.  
**R12.** Use the little block for alignment.

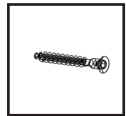

**40x** M7x20 Wood  
Screw

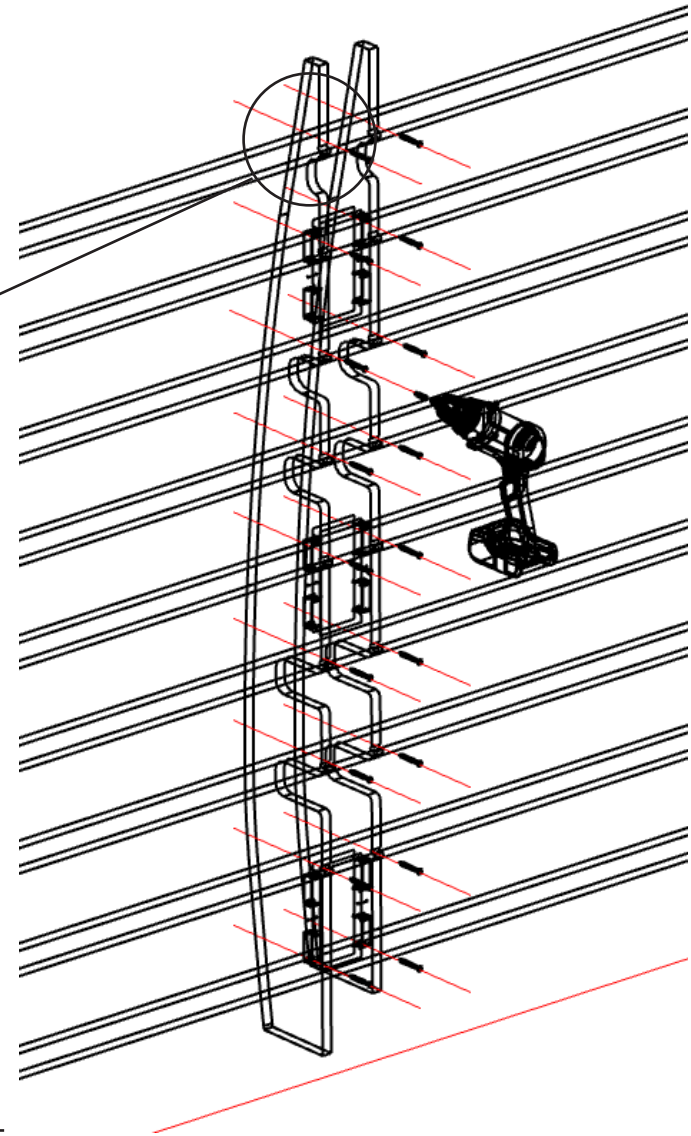
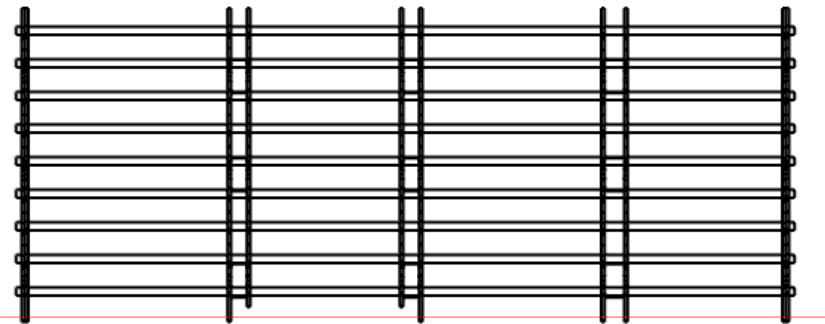
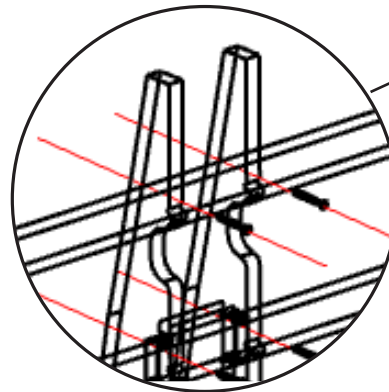

**1x** Drill

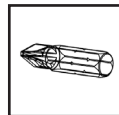

**1x** Screw Driver Bit

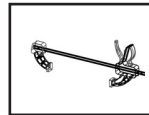

**5x** One Hand Clamp

# STEP 2.2 ATTACHING THE LEFT BARS 2

Step 7/19

🕒 90 min

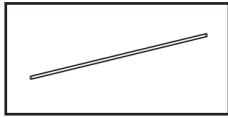

**9x** 24x74x4235 Bars



**R13.** Clamp the bars.

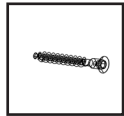

**72x** M7x20 Wood  
Screw

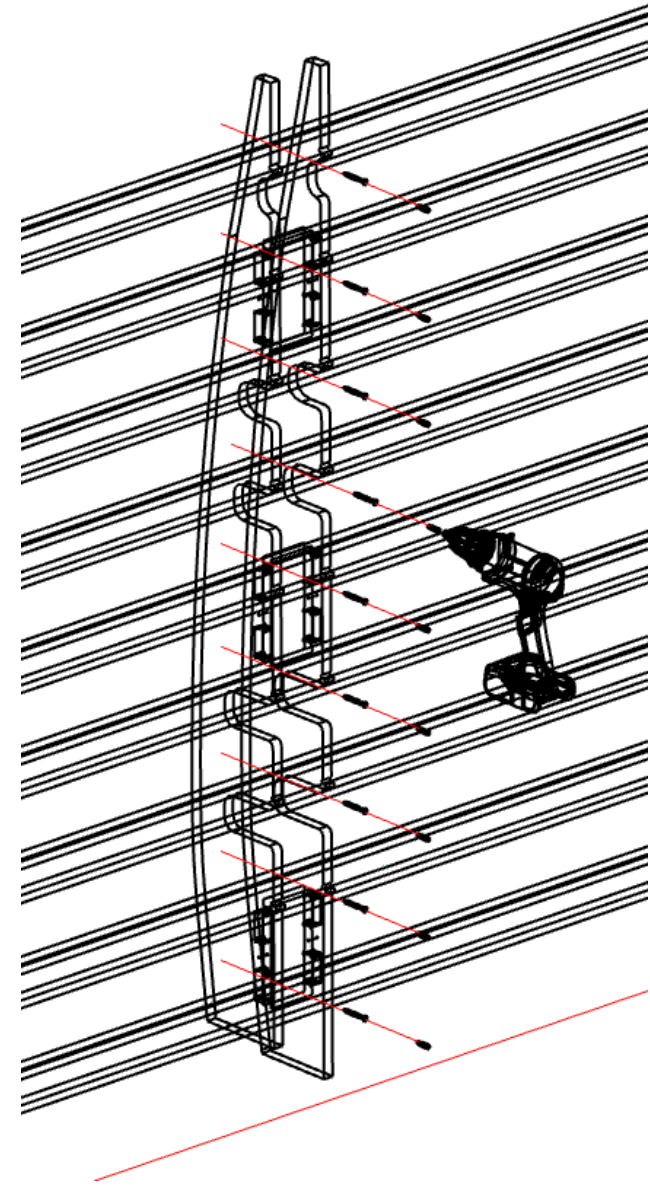
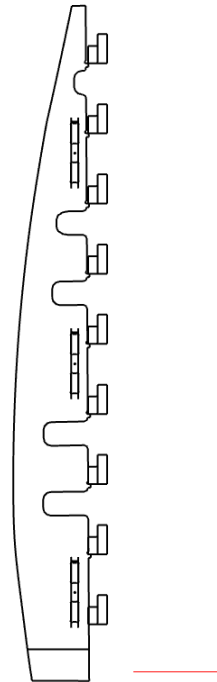

**1x** Drill

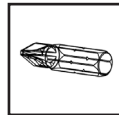

**1x** Screw Driver Bit

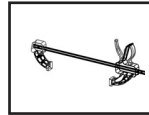

**5x** One Hand Clamp

# STEP 3.1 ASSEMBLING A BOX

Step 8/19  30 min



**2x** Top and Bottom Plates



**2x** Side Plates



**12x** M7x20 Wood Screw



**R14.** Use the soft-faced hammer.

**R15.** This is the instruction to make one box.

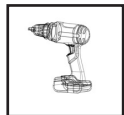
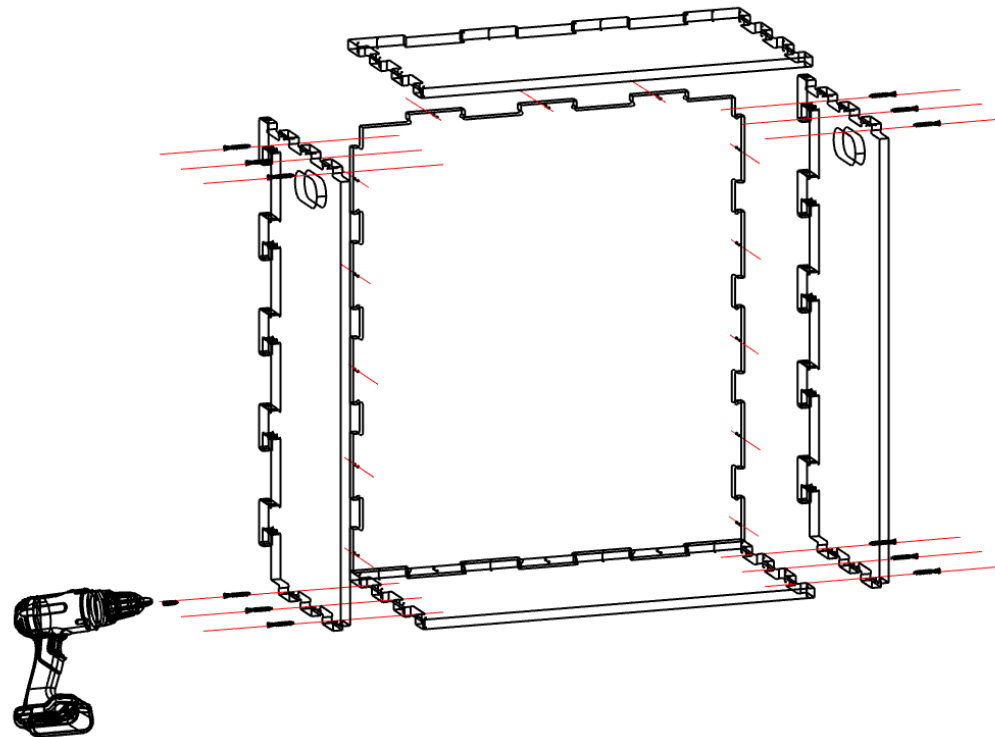

**1x** Drill

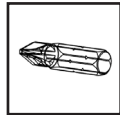

**1x** Screw Driver Bit



**1x** Soft-faced Hammer

# STEP 3.2 ASSEMBLING A LEG

Step 9/19 ⌚ 15 min

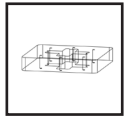

1x Leg A



1x Leg B

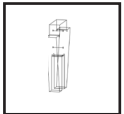

1x Leg C



2x M7x20 Wood Screw



**R16.** Use the soft-faced hammer.

**R17.** This is the instruction to make one leg.

**R18.** Each box need three legs.



**H2.** How to use the soft hammer?

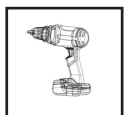
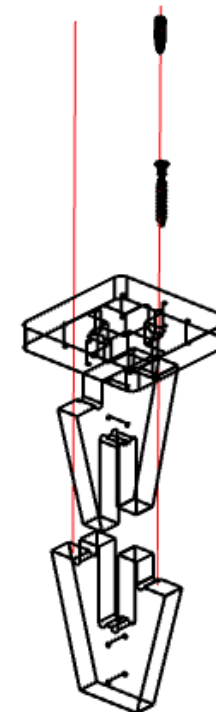
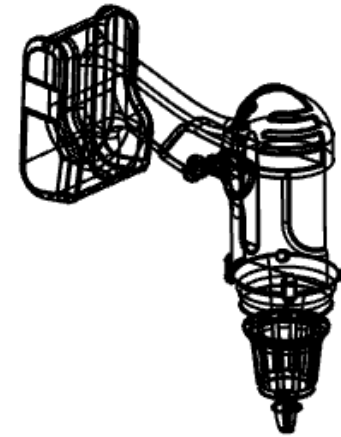

1x Drill

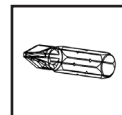

1x Screw Driver Bit

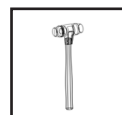

1x Soft-faced Hammer

# STEP 3.3 ATTACHING THE LEGS

Step 10/19 ⌚ 15 min

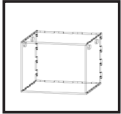

**1x** Box

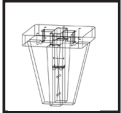

**3x** Legs

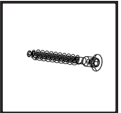

**12x** M7x20 Wood  
Screw

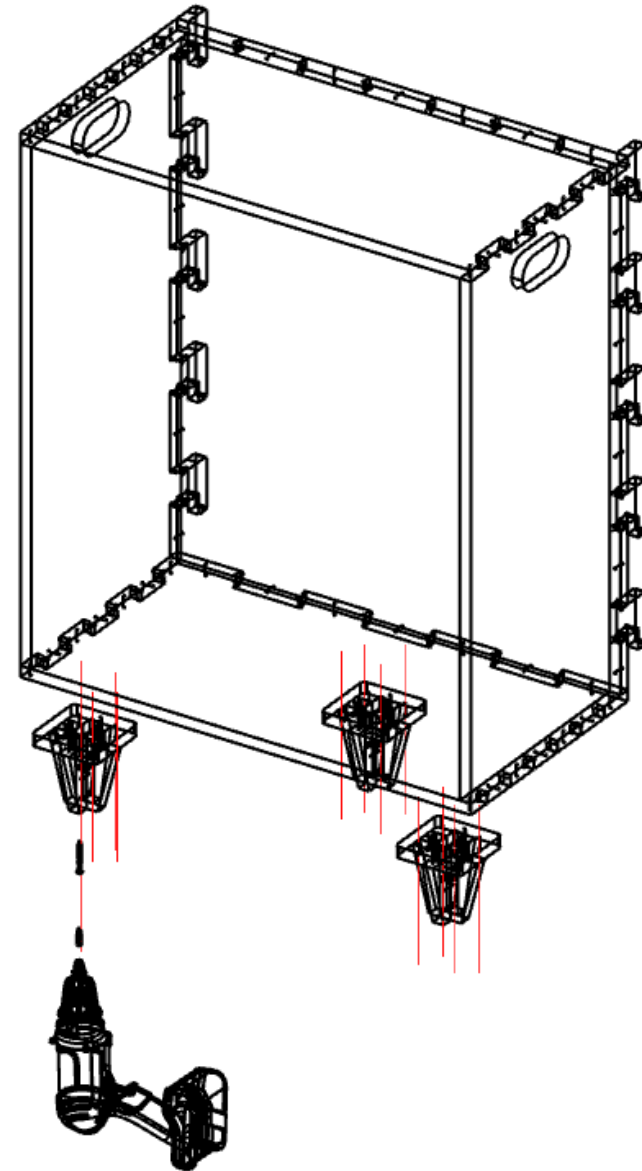

**1x** Drill

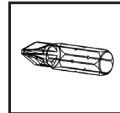

**1x** Screw Driver Bit

# STEP 3.4 ASSEMBLING MORE BOXES

Step 11/19

🕒 130 min

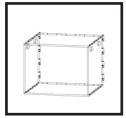

**3x** Boxes



**4x** Boxes with legs



**R19.** Box number 1,2,6,7 need legs.

**R20.** See steps 3.1 and 3.2 to build more legs and boxes

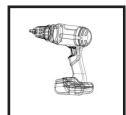
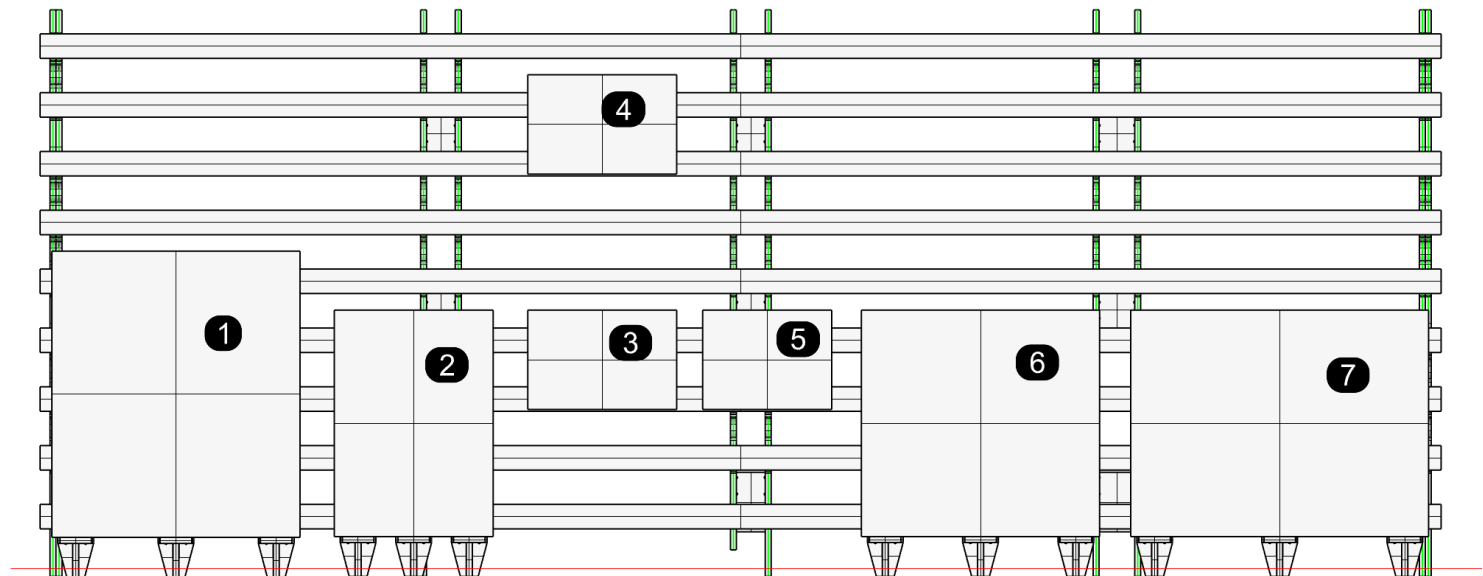

**1x** Drill

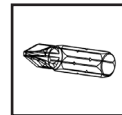

**1x** Screw Driver Bit



**1x** Soft-faced Hammer

# STEP 4.1 PREPARING THE RIGHT PILLARS

Step 6/19 ⌚ 30 min

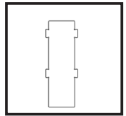

2x Right Pillar

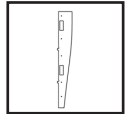

4x Middle Pillar

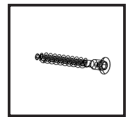

12x M7x20 Wood Screw



**R21.** Use soft-faced hammer to assemble the pillars.



**H2.** How to use the soft hammer?

**R22.** Pay attention to assemble them in the correct position between long and short pillars.

**R23.** Assembly all the 3 right pillars (Number 6,7 and 8).

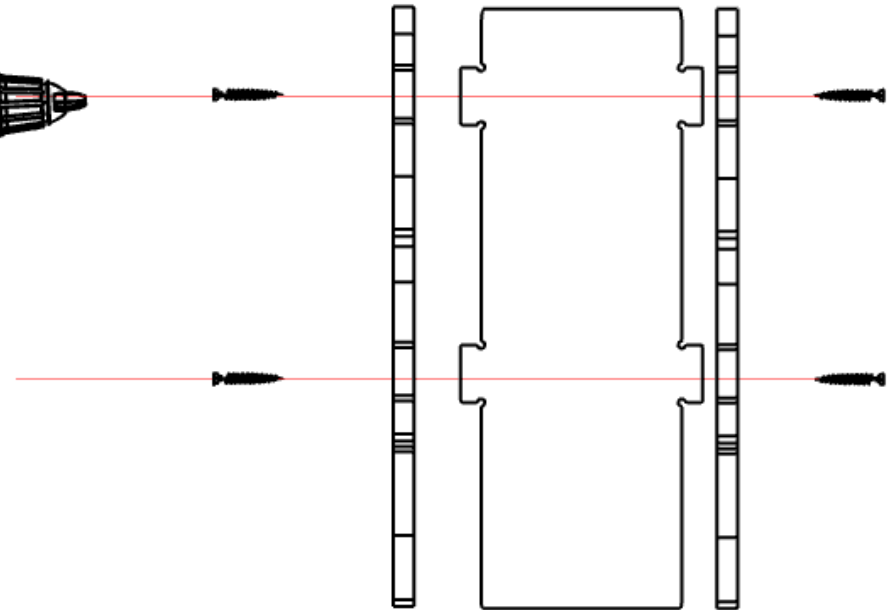
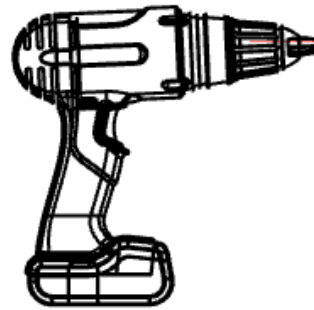
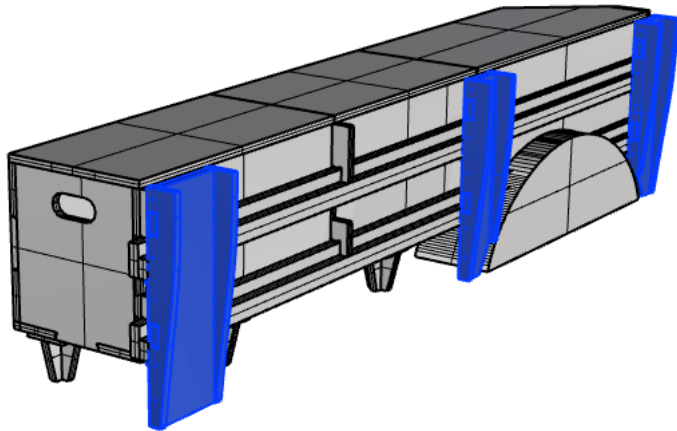

1x Drill

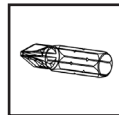

1x Screw Driver Bit

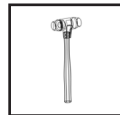

1x Soft-faced Hammer

# STEP 4.2 PREPARING TO ASSEMBLY

## THE RIGHT PILLARS

Step 12/19

🕒 50 min



**3x** Pillars (Number 6,7 and 8)



**R24.** Clamp the pillars.

**R25.** Assembly all the 3 right pillars (Number 6,7 and 8).



**H1.** How to use one hand clamp?

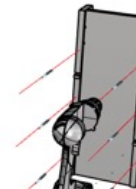
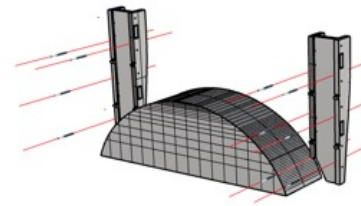
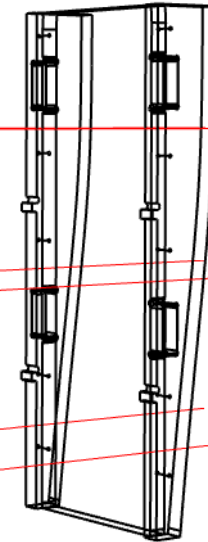
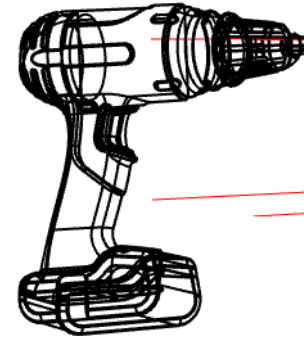
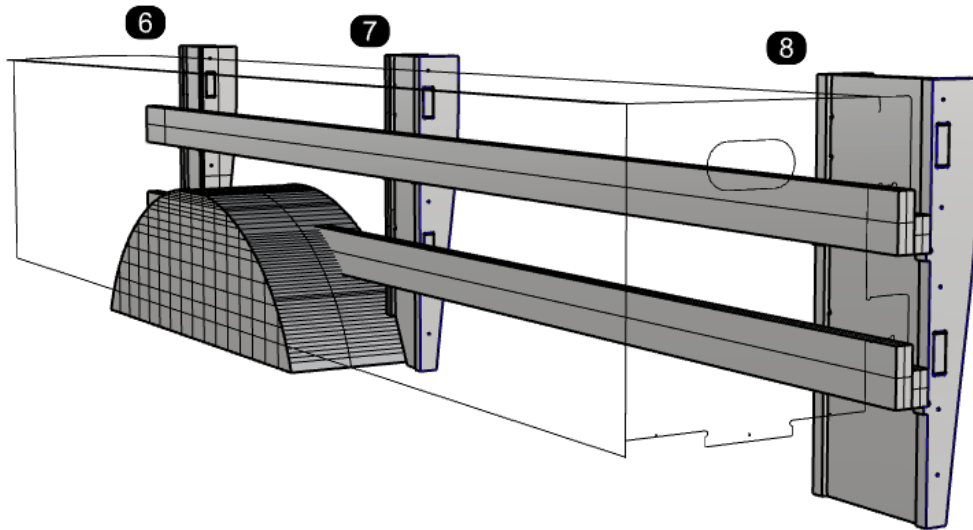

**1x** Drill



**1x** D7mm Wood Drill Bit

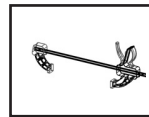

**3x** One Hand Clamp

# STEP 4.3 ASSEMBLING THE RIGHT PILLARS

Step 13/19

🕒 50 min



**3x** Pillars (Number 6,7 and 8)

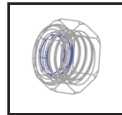

**40x** M7 Lock Nuts

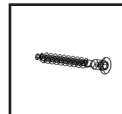

**40x** M7x80 Screw



**R26.** Clamp the pillars.  
**R27.** Assembly all the 3 right pillars (Number 6,7 and 8).



**H2.** How to use Lock Nuts? p.

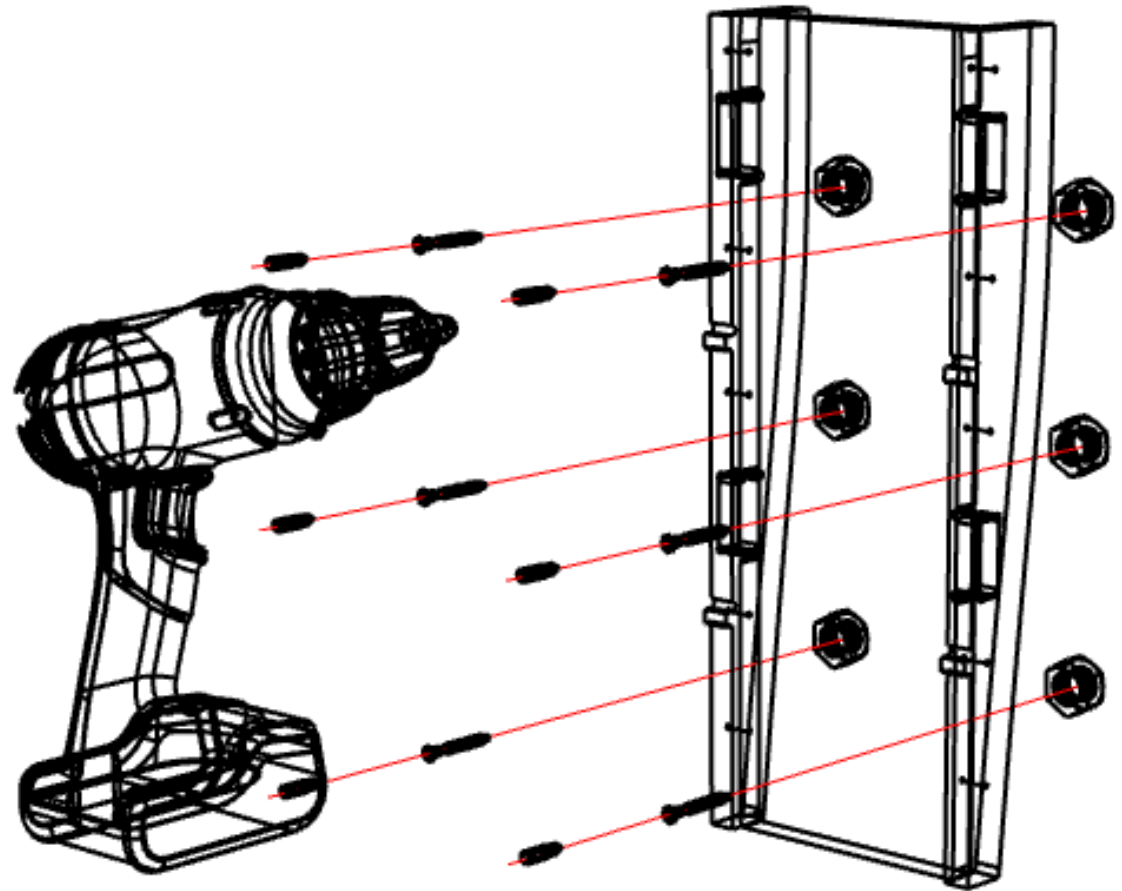

**1x** Drill

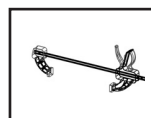

**3x** One Hand Clamp

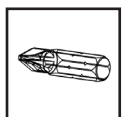

**1x** Screw Driver Bit

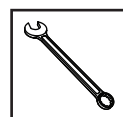
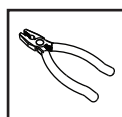

**1x** Small plier **or**  
**1x** Wrench 5.5

# STEP 5.1 ATTACHING THE RIGHT BARS 1

Step 14/19

🕒 90 min

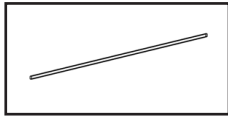

**9x** 24x74x2335 Bars



**R29.** Clamp the bars.

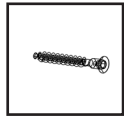

**72x** M7x20 Wood  
Screw

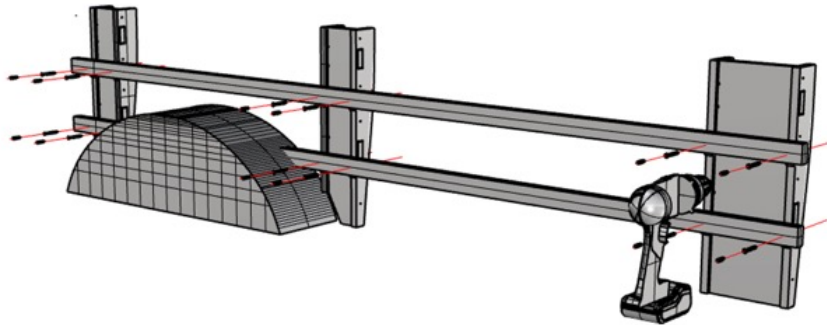
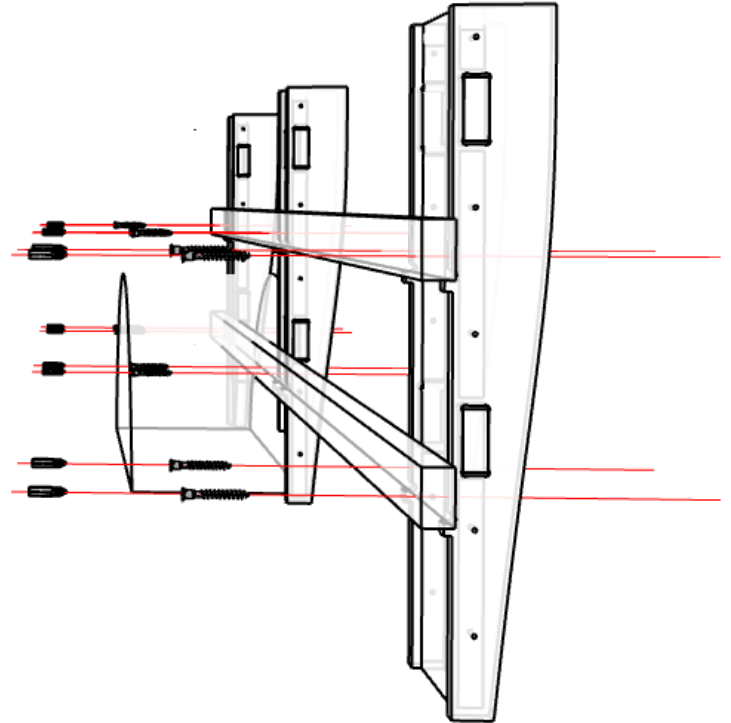

**1x** Drill

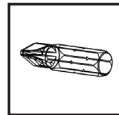

**1x** Screw Driver Bit

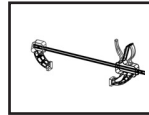

**5x** One Hand Clamp

# STEP 5.2 ATTACHING THE RIGHT BARS 2

Step 15/19

🕒 90 min

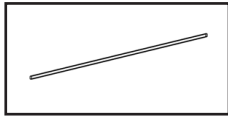

**9x** 24x74x4235 Bars



**R30.** Clamp the bars.

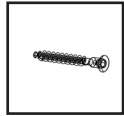

**72x** M7x20 Wood  
Screw

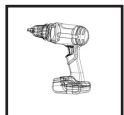
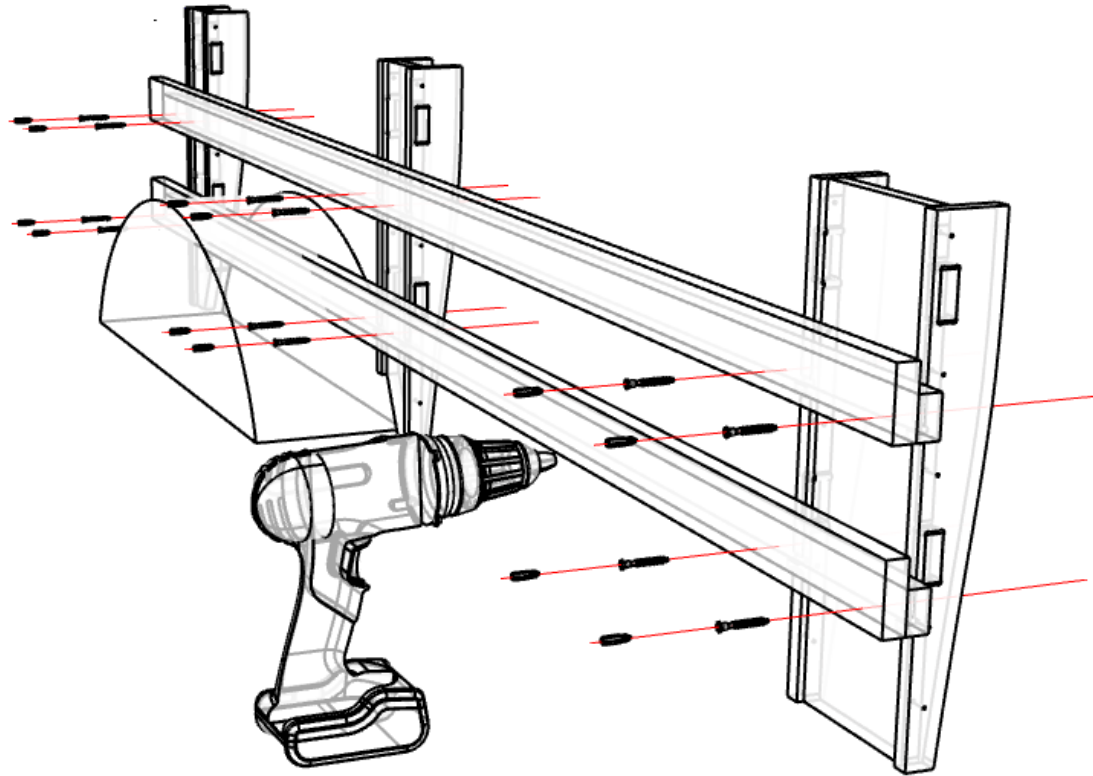

**1x** Drill

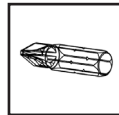

**1x** Screw Driver Bit

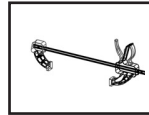

**5x** One Hand Clamp

# STEP 6.1 ASSEMBLING RIGHT ROW

Step 16/19

🕒 30 min

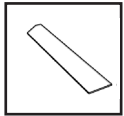

**2x** Top and Bottom Right Plates

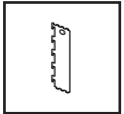

**3x** Side Plates Right

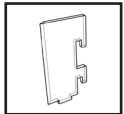

**1x** Side Plates A

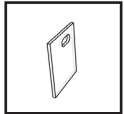

**1x** Side Plates B

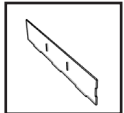

**2x** Back Plates A

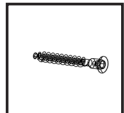

**12x** M7x20 Wood Screw



**R31.** Use the soft-faced hammer.  
**R32.** This is the instruction to make one box.

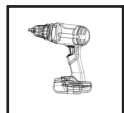
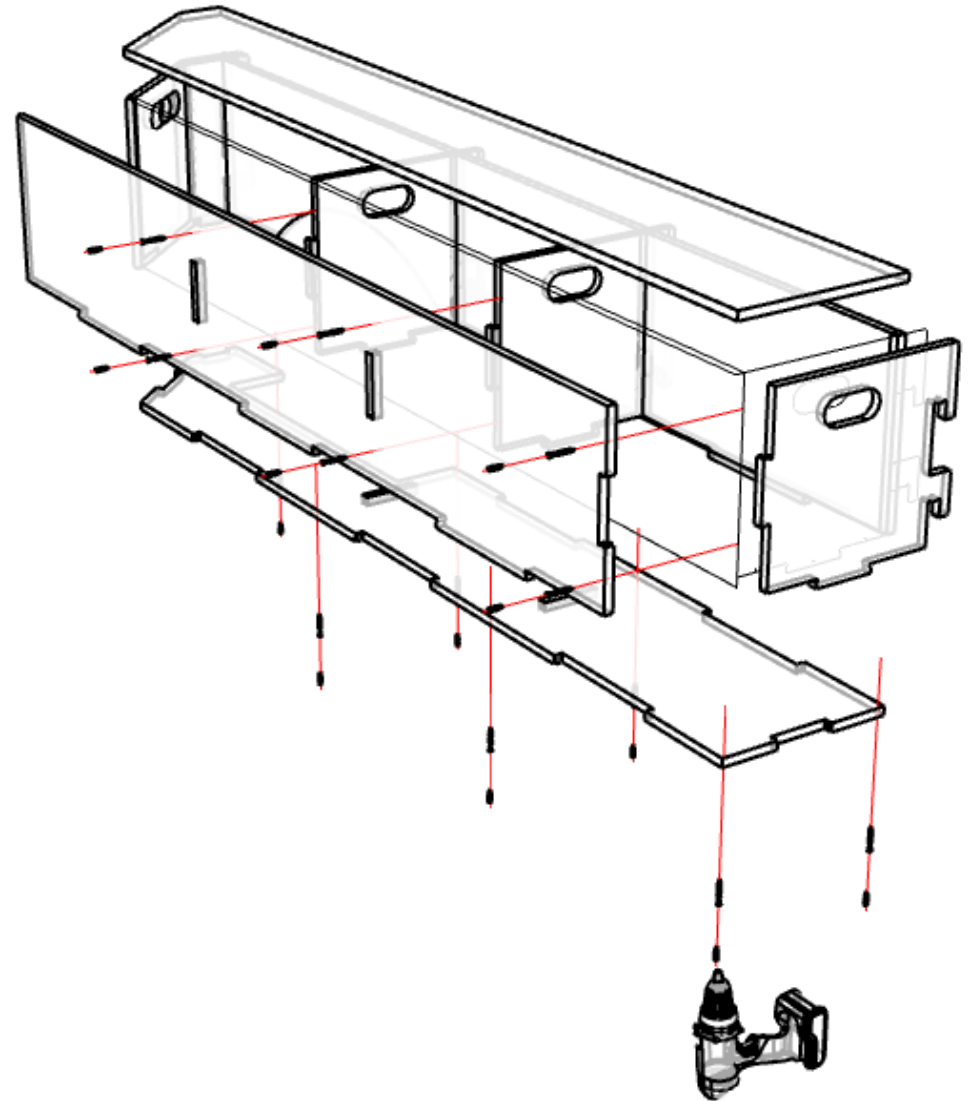

**1x** Drill

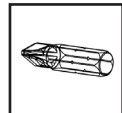

**1x** Screw Driver Bit



**1x** Soft-faced Hammer

# STEP 6.2 ATTACHING LEGS FOR THE RIGHT BOX

Step 17/19

🕒 25 min

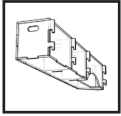

**1x** Long box



**R33.** Build Legs.

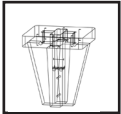

**3x** Legs



**12x** M7x20 Wood  
Screw

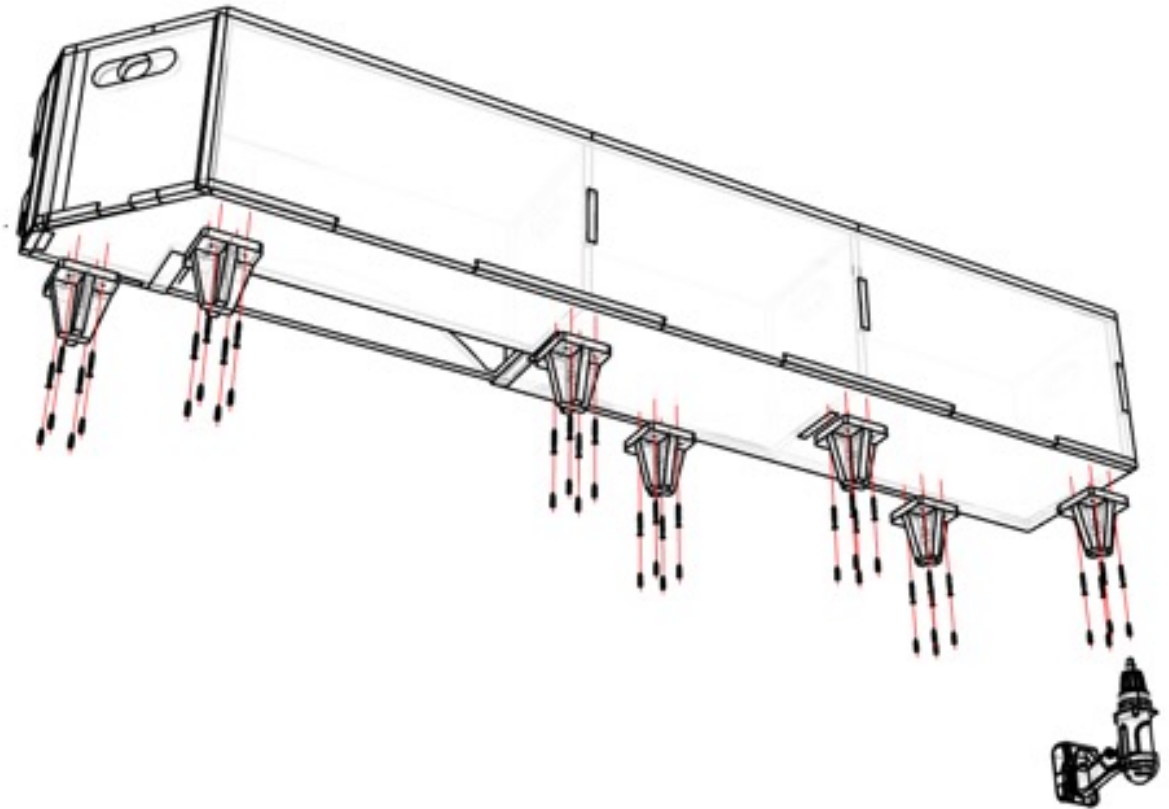

**1x** Drill

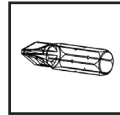

**1x** Screw Driver Bit

# STEP 6.3 RIGHT BOX INSTALLATION

Step 18/19

🕒 5 min

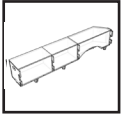

**1x** Long box with legs



**R34.** Box number 1,2,6,7 need legs.



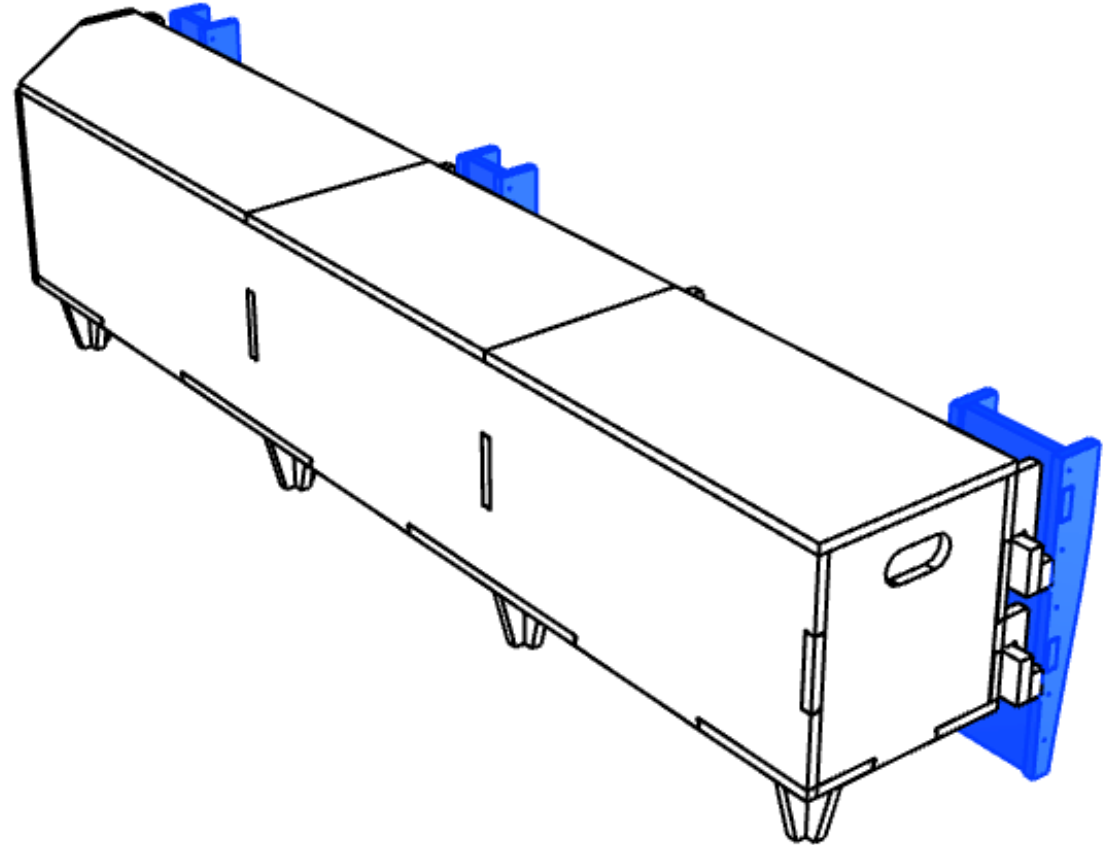

**R35.** See steps 3.1 and 3.2 to build the legs and boxes





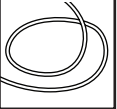
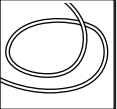
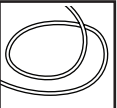
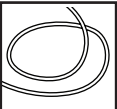

# STEP 7.1 WIRING ELECTRONIC

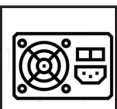
Step 19/19

⌚ 420 min

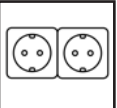
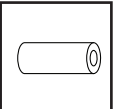
-  **4x** 2 Wire Cable
-  **6x** 3 Wire Cable
-  **6x** 2 Wire Jumper Cable
-  **6x** 1 Wire Jumper Cable
-  **2x** Solar Pannel Array
-  **2x** 3-Way Selector
-  **1x** Power Regulator (Bluetti D050S)
-  **1x** Power Module (Bluetti AC200 + B230)

-  **2x** Residual-Current Device (RCD) 25 A
-  **2x** Circuit Breaker 25 A
-  **8x** 2-Power Plug
-  **16x** Cable Tube

 **R36.** High voltage, please have an experienced supervisor.

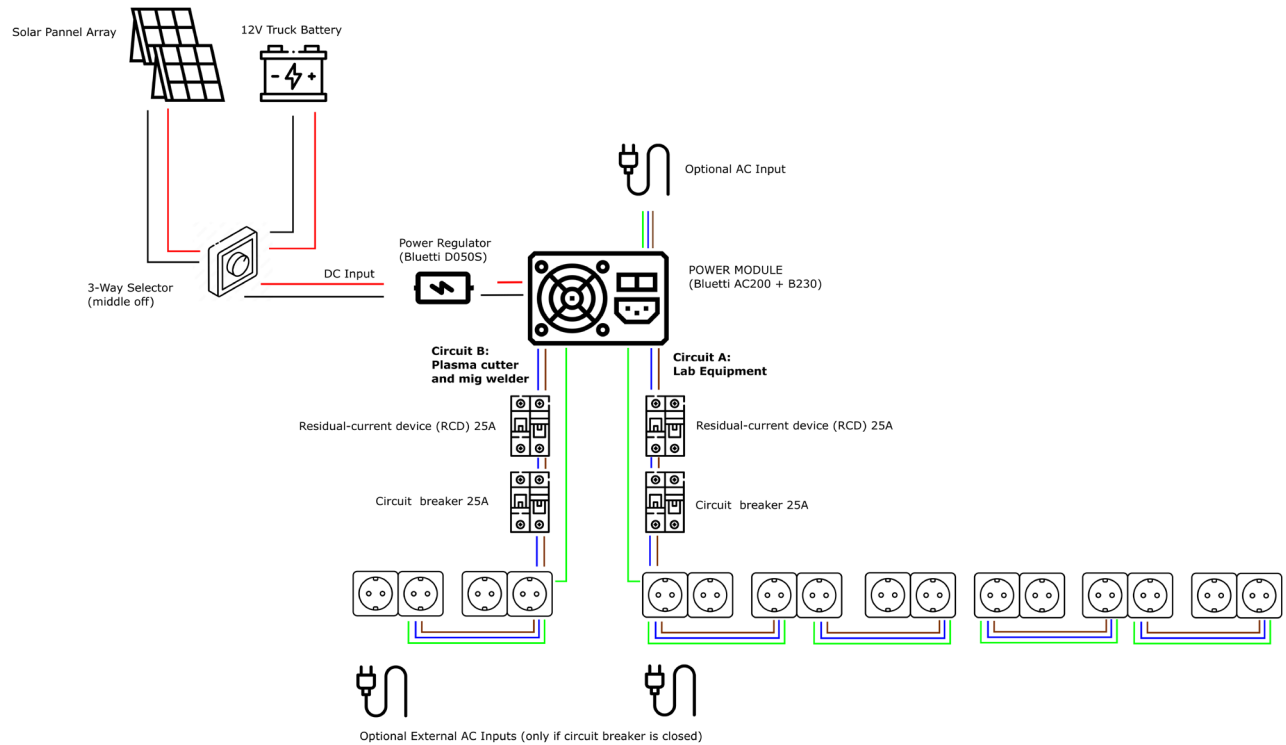

 **1x** Screwdriver slotted small

 **1x** Screwdriver Philipps 6

# STEP 8.1 CELEBRATE!

Congratulations! You just finished assembling a complete Mobile Fab Lab 1!

Now your Mobile Fab Lab 1 is ready to assist you on your projects.

Have fun!

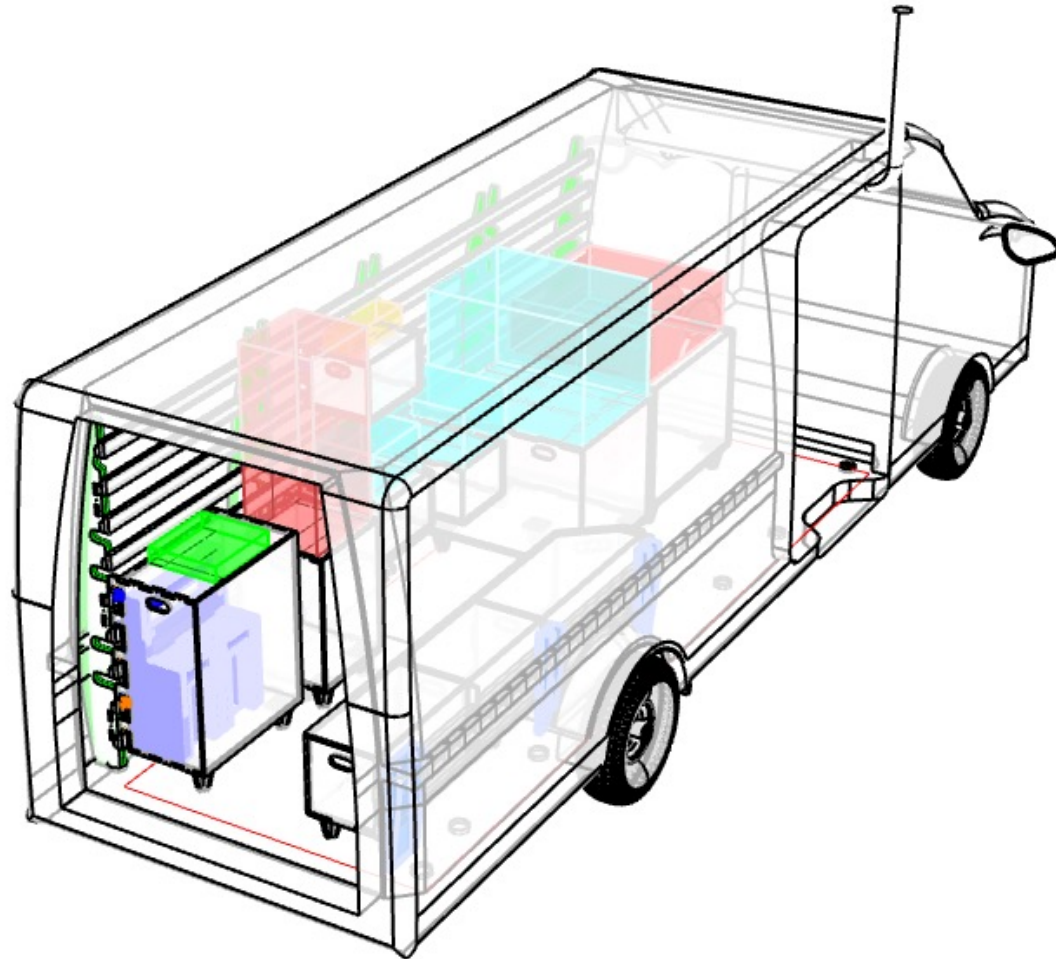

# TROUBLESHOOTING

## PROBLEM

## CHECKS AND SOLUTIONS

The machine axis are not moving

- The machine is not switched on.
- The power plug is disconnected.
- The fuse, located inside the main power plug, is open or has been removed.
- The Stepper Power Supply does not receive electricity; check the relevant connections.
- The Stepper Power Supply is damaged; check if there are 24V with a multimeter.
- The Stepper Shield does not receive the 24V; check the relevant connections.
- If only one axis does not move, maybe that one Stepper Driver is damaged; change it and try again.
- The couplers, belts or pulley are loose; check them.
- The Endstop Switches are triggered; check if the axis are away from them and/or anything is blocking them.

It is not possible to connect to the machine

- Within the UGS software, check if you are using the correct COM port (serial port); change it in this case.
- Check if the baud rate is 9600, change it in this case.
- Check if the USB to Serial connections are correct.
- The Arduino could be damaged; check if the green light (located into the Arduino board) is on.

The machine stops in the middle of a job

- Check if the stepper motor cables are not close to the USB to Serial Cable.
- Check if your PC is not blocked and/or too slow.
- Check if the USB to Serial has not been accidentally removed.
- Check if the endstop have not been triggered during the job.
- Check if the chiller has not been powered off accidentally.

## PROBLEM

## CHECKS AND SOLUTIONS

The laser is not firing

- The machine is not switched on.
- The power plug is disconnected.
- The fuse, located inside the main power plug, is open or has been removed.
- The laser power supply does not receive electricity; check the relevant connections.
- The laser tube does not receive power; check Laser+ and Laser- connections.
- The chiller is switched off (the water flow sensor is not active); switch the water chiller on.
- The laser window is open; close it.
- The laser path lost its calibration; check it with masking tape, see "how to calibrate" the laser. (Step 21)
- The window switches and relative cables are damaged; check them and change them in this case.
- The GCode is wrong and does not contain any "M3" and "SXX" values.
- The "Laser Comm" cable is damaged; check it.
- The Laser Power Supply wiring is not correct; check it.

# LIST OF PARTS

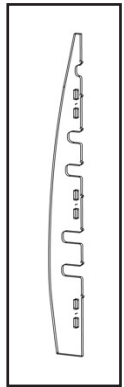

**12x** Long Pillars  
**2x** Short Pillars

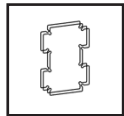

**9x** Pillar Attachments

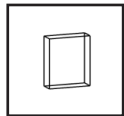

**12x** Wood Blocks

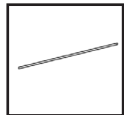

**9x** 24x44x4235 Bars

**9x** 24x74x4235 Bars

**9x** 24x74x2335 Bars

**9x** 24x74x4235 Bars

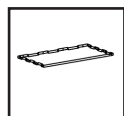

**2x** Top and Bottom Plates

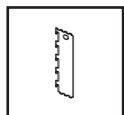

**2x** Side Plates

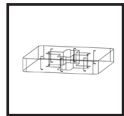

**1x** Leg A



**1x** Leg B

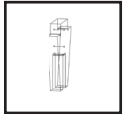

**1x** Leg C

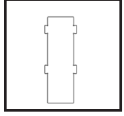

**2x** Right Pillar

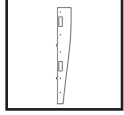

**4x** Middle Pillar

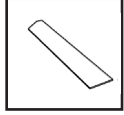

**2x** Top and Bottom Right Plates

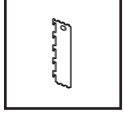

**3x** Side Plates Right

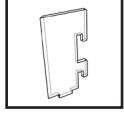

**1x** Side Plates A

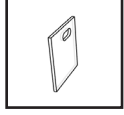

**1x** Side Plates B

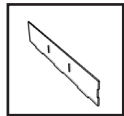

**2x** Back Plates A

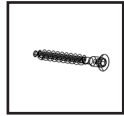

**136x** M7x20 Wood Screw

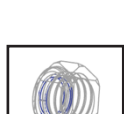

**40x** M7x80 Screw

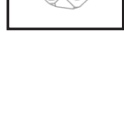

**40x** M7 Lock Nuts

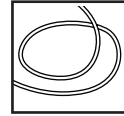

**4x** 2 Wire Cable

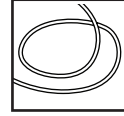

**6x** 3 Wire Cable

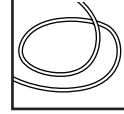

**6x** 2 Wire Jumper Cable

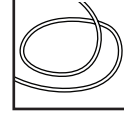

**6x** 1 Wire Jumper Cable

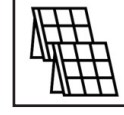

**2x** Solar Panel Array

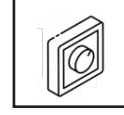

**2x** 3-Way Selector



**1x** Power Regulator (Bluetti D050S)

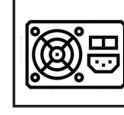

**1x** Power Module (Bluetti AC200 + B230)

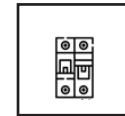

**2x** Residual-Current Device (RCD) 25 A

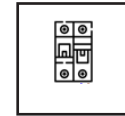

**2x** Circuit Breaker 25 A

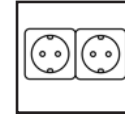

**8x** 2-Power Plug

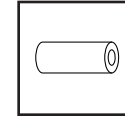

**16x** Cable Tube

## **INMACHINES.NET**

Daniele Ingrassia  
Birtener Ring 8B  
46509, Xanten

0049-177-4978312  
daniele@inmachines.net

## **AUTHORS & LICENSORS**

**ASSEMBLY MANUAL (CC BY-SA 4.0)**  
Marcello Tania

**ASSEMBLY MANUAL TEMPLATE (CC BY-SA 4.0)**  
Marc Kohlen  
Liane Sayuri Honda

**MACHINE HARDWARE (CERN-OHL-W)**  
Daniele Ingrassia / InMachines Ingrassia GmbH

## **CONTACTS**

marcello\_tania@yahoo.com

marckohlen@3dinx.com  
licasayurih@gmail.com

daniele@inmachines.net



This work is licensed under the Creative Commons Attribution-ShareAlike 4.0 International License.  
To view a copy of this license, visit <http://creativecommons.org/licenses/by-sa/4.0/>