

# The A Team

## The Abundant Free Food Kiosk



Designed by The A Team:

Jennifer Barranco

Jessica Horton

Megan Moore

Ernesto Silva

**Humboldt State University**

**ENGR 215: Introduction to Engineering Design**

**Fall 2016**

**Client: The Sanctuary Arcata CA**

# Table of Contents

1	Problem Formulation .....	1
1.1	Introduction.....	1
1.2	Objective.....	1
1.3	Black Box Model .....	1
2	Problem Analysis and Literature Review .....	2
2.1	Problem Analysis .....	2
2.1.1	Introduction to Problem Analysis .....	2
2.1.2	Specifications .....	2
2.1.3	Considerations.....	2
2.1.4	Criteria .....	2
2.1.5	Usage.....	3
2.1.6	Production Volume .....	3
2.2	Literature Review.....	3
2.2.1	Introduction.....	3
2.2.2	Client Interview .....	3
2.2.3	Criteria .....	3
2.2.4	Examples and Methods.....	4
2.2.4.1	Little Free Pantry .....	4
2.2.4.2	Little Free Library .....	5
2.2.4.3	Paleta Cart.....	5
2.2.4.4	Nanma Maram .....	7
2.2.5	Heating and cooling methods.....	8
2.2.5.1	What is passive solar design .....	8
2.2.5.2	Types of heating/cooling .....	8
2.2.6	The reuse of materials .....	9
2.2.6.1	What is upcycling? .....	9
2.2.6.2	Recycling.....	9
2.2.6.3	Examples of upcycled and recycled materials.....	9
2.2.7	California food laws.....	10

2.2.7.1	Storage of food .....	10
2.2.7.2	Distribution of food .....	10
2.2.8	Heat capacity.....	10
2.2.9	Thermal conduction .....	10
2.2.10	Insulation.....	11
2.2.11	Heat`s effect on food.....	11
2.2.12	Solar radiation (Arcata).....	11
2.2.13	Refrigeration .....	11
2.2.13.1	Introduction .....	11
2.2.14	Accessibility.....	14
2.2.14.1	Introduction .....	14
2.2.15	Building materials for outdoors .....	15
2.2.15.1	Hot dipped galvanized metal .....	15
2.2.15.2	Wood .....	16
2.2.15.3	Aluminum.....	16
2.2.15.4	Plexiglass.....	16
2.2.16	Awning.....	17
3	Alternative Solutions .....	18
3.1	Introduction.....	18
3.2	Brainstorming .....	18
3.3	The Cold Mailbox .....	19
3.4	The Zeer Box .....	19
3.5	The House Cabinet.....	20
3.6	The Chill Slider.....	21
3.7	The Zeer Slider .....	22
3.8	The Pyramid.....	23
3.9	The Kool Cabinet.....	24
3.10	The Terra Cottage .....	25
3.11	The Hot Shelf.....	26
3.12	The Chill Hatch.....	27
3.13	Pot o` Gold.....	28
3.14	The No Chill Hatch.....	29

4	Decision Process .....	30
4.1	Introduction.....	30
4.2	Criteria .....	30
4.3	Solutions .....	31
4.4	Decision Process .....	31
4.5	Final decision .....	33
5	Specification of solution .....	33
5.1	Introduction.....	33
5.2	Solution description .....	34
5.2.1	The Frame .....	34
5.2.2	The Upper Cabinet.....	34
5.2.3	The Roof .....	35
5.2.4	The Doors.....	35
5.2.5	The Waterproof Coating .....	36
5.3	Cost Analysis .....	36
5.3.1	Introduction.....	36
5.3.1.1	Design Cost.....	36
5.3.1.2	Materials Cost.....	36
5.3.1.3	Maintenance Cost .....	37
5.3.2	Instructions for implementation and use of model .....	37
5.3.3	Results and discussion .....	38
Appendix A	Brainstorming sessions.....	I
Appendix B	Prototyping Photos .....	IV
Appendix C	References .....	VIII

## List of Tables

Table 2-1	A list of the criteria and constraints for the abundant free food kiosk .....	2
Table 4-1	Delphi Matrix of Alternative Solutions .....	32
Table 4-2	List of criteria and their weight .....	33
Table 5-1	The list of materials and their respective costs needed to build the abundant free food kiosk.....	37

Table 5-2 Materials needed to maintain the project, time it will take to use that material to maintain the project and the annual cost of the maintenance .....	37
---	----

**List of Figures**

Figure 1-1 The Black Box Model for the abundant free food kiosk.....	1
Figure 2-1 The original Little Free Pantry (LFP) ( <a href="https://www.facebook.com/littlefreepantry/">https://www.facebook.com/littlefreepantry/</a> ....	4
Figure 2-2 Paleta cart frame with cardboard wheels, a prototype .....	5
Figure 2-3 Paleta cart frame with real wheels .....	6
Figure 2-4 Paleta cart with insulation and outer walls.....	6
Figure 2-5 Final Paleta cart with designs.....	7
Figure 2-6 The refrigerator that Pauline placed outside of her restaurant .....	7
Figure 2-7 A trombe wall using indirect gain to heat an enclosed space .....	9
Figure 2-8 Zeer pot design with cross-section (R 2016).....	12
Figure 2-9 Schematic of a vapor compression refrigeration system (Klein and Reindl 2005).....	13
Figure 2-10 Schematic of a solar driven mechanical power cycle (Klein and Reindl 2005) .....	13
Figure 2-11 Schematic of an ammonia-water absorption refrigeration system (Klein and Reindl 2005) .....	14
Figure 2-12 A stack of galvanized steel sheets .....	15
Figure 2-13 A Plexiglas food display box .....	17
Figure 2-14 an example of an awning used in front of a bakery .....	17
Figure 3-1 Base Model includes the set dimensions, stand, and back cabinet doors that will be used for all alternative solutions .....	18
Figure 3-2 The Cold Mailbox is a two-compartment box that uses the chill box refrigeration method, has mailbox doors in the front, and has a slanted roof for cover. A vent is located on the side of the chill box compartment for ventilation.....	19
Figure 3-3 The Zeer Box is a two-compartment box that uses the zeer pot refrigeration method, has mailbox doors in the front, and has a slanted roof for cover. A vent is located on top of the compartment without refrigeration for ventilation. ....	20
Figure 3-4 The House Cabinet is a single unit box that has a mailbox door in the front, a triangle roof for cover and no method of refrigeration. A vent is located on the top and side of the unit for ventilation. ....	21
Figure 3-5 The Chill Slider is a two-compartment box that uses the chill box refrigeration method, has sliding doors in the front, and has a slanted roof for cover. A vent is located on the side of the chill box compartment for ventilation. ....	22
Figure 3-6 The Zeer Slider is a two-compartment box that uses the zeer pot refrigeration method, has sliding doors in the front, and has a slanted roof for cover. A vent is located on top of the zeer pot compartment for ventilation.....	23
Figure 3-7 The Pyramid is a single unit box that has a sliding door in the front, a triangle roof for cover and no method of refrigeration. A vent is located on both sides of the unit for ventilation. ....	24

Figure 3-8 The Kool Kabinet is a two-compartment box that uses the chill box refrigeration method, has cabinet doors in the front, and has a slanted roof for cover. A vent is located on the side of the chill box compartment for ventilation. ....	25
Figure 3-9 The Terra Cottage is a two-compartment box that uses the zeer pot refrigeration method, has cabinet doors in the front, and has a triangle roof for cover. A vent is located on top of the zeer pot compartment for ventilation. ....	26
Figure 3-10 The Hot Shelf is a two-compartment box that has cabinet doors in the front, a triangle roof for cover and no method of refrigeration. A vent is located on the both sides of the unit for ventilation. ....	27
Figure 3-11 The Chill Hatch is a two-compartment box that uses the chill box refrigeration method, has hatch doors in the front, and has a slanted roof for cover. A vent is located on the side of the chill box compartment for ventilation. ....	28
Figure 3-12 Pot o' Gold is a two-compartment box that uses the zeer pot refrigeration method, has hatch doors in the front, and has a triangle roof for cover. A vent is located on top of both compartments for ventilation. ....	29
Figure 3-13 The No Chill Hatch is a single unit box that has a hatch door in the front, a triangle roof for cover and no method of refrigeration. A vent is located on the top and side of the unit for ventilation. ....	30
Figure 5-1 A view of the frame of kiosk. ....	34
Figure 5-2 A side view of the upper cabinet that includes thickness, length and height dimensions .....	35
Figure 5-3 A pie chart representing The A Teams total time spent on the abundant free food kiosk. ....	36

# 1 Problem Formulation

## 1.1 Introduction

The purpose of this section is to introduce the project and its purpose for the ENGR 215 course in the Fall 2016 semester. The A team will be working with the nonprofit organization *The Sanctuary*, based in Arcata, California. *The Sanctuary* provides a means of strengthening the community through activities that promote sharing of creative ideas and resources. Some of these activities are open pottery courses, open sewing sessions, and tap dancing lessons. All these activities are free and open to anybody who would like to participate. The Sanctuary frequently receives an abundance of free food that, if not distributed to the community, ends up getting spoiled. All this food is meant to be given away to anyone who would like some, but the lack of awareness that the food is available leads to food going bad and being wasted.

## 1.2 Objective

The purpose of The A-Team`s project is to design and implement a permanent free food kiosk for The Sanctuary that will provide a more efficient means of distributing the food to the community. The plan is to utilize the client`s resources and reusable materials to design a low-cost structure. The goal is to design a kiosk so that the food is accessible from the sidewalk, and for community members, who are not aware of the free food, can now have an opportunity to be a recipient of this food.

## 1.3 Black Box Model

Figure 1-1 illustrates The Black Box Model`s purpose to show how the world will be before and after the implementation of the A-Team`s project.

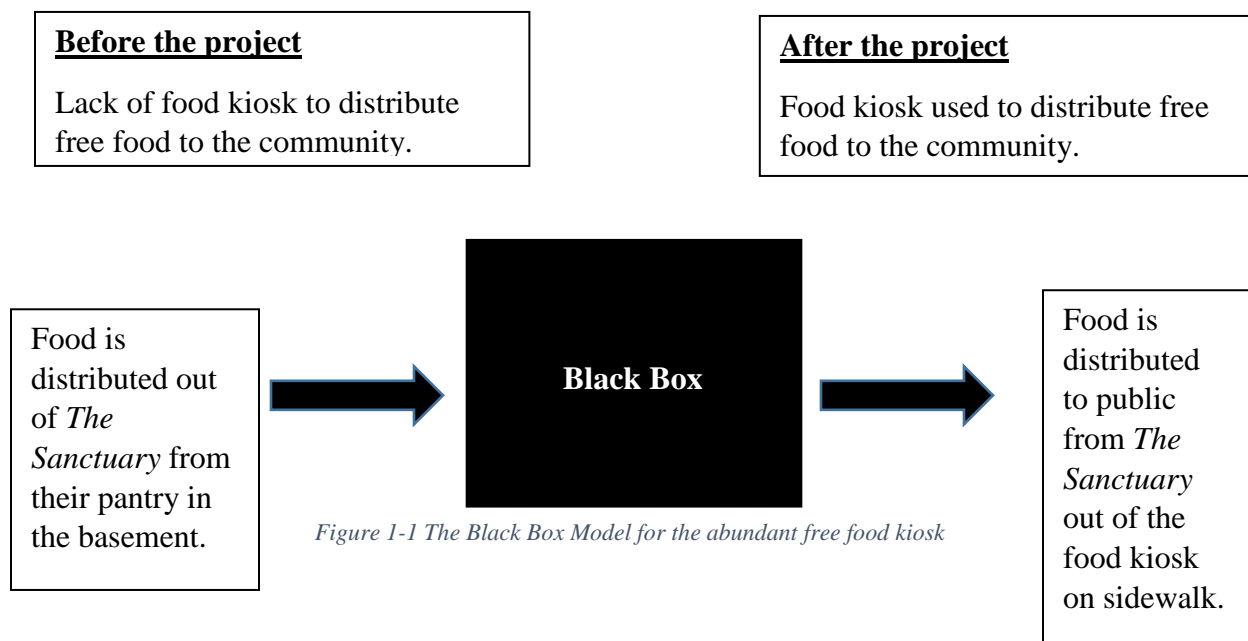

Figure 1-1 The Black Box Model for the abundant free food kiosk

## 2 Problem Analysis and Literature Review

### 2.1 Problem Analysis

#### 2.1.1 Introduction to Problem Analysis

Section two describes the problem analysis of the abundant free food kiosk designed for The Sanctuary. Section two will go over specifications addressed by the client required for the design of the kiosk and considerations that need to be kept in mind when designing and building the kiosk. Also, included in this section is criteria and constraints, usage and production volume.

#### 2.1.2 Specifications

The following requirements need to be implemented in the design of the abundant free food kiosk:

- The portion of the kiosk that will store the food needs to be six feet long, two feet deep and two feet tall
- The entire kiosk has two points of access
  - One, the public can access the food from the front
  - One, the client can access the food from the back

#### 2.1.3 Considerations

Some aspects to keep in mind when building the abundant free food kiosk are:

- The overall height of the entire kiosk depends on the height of the tallest part of the sidewalk (which is slanted from the street)
- Accommodations for the direct sun that hits the kiosk location
- The kiosk needs to be built to withstand the rainy season

#### 2.1.4 Criteria

Criteria are guidelines that can be judged how successful the project is. The constraints are the range in which the criterion can be weighed. The criteria and constraints for the abundant free food kiosk can be seen in table 2-1.

**Table 2-1: Criterion and Constraints**

<b>Criteria</b>	<b>Constraints</b>
Aesthetics	Must look pleasing and professional to the eye
Cost	Can't exceed four hundred dollars (one hundred dollars from The Sanctuary, seventy-five dollars from each group member.
Replicability	Simple enough to be rebuilt by amateurs.
Safety	No chemicals or other harmful contaminants will be able to taint the food inside the kiosk. There can't be splinters.
Accessibility	Accessible for all people, including children.
Durability	Needs to last at least ten years.

*Table 2-1 A list of the criteria and constraints for the abundant free food kiosk*

### 2.1.5 Usage

The abundant free food kiosk will be implemented to provide free food to the community of Arcata. On the days that The Sanctuary is open, it will be accessible from dusk to dawn for individuals to come by and access free food. The kiosk will be stocked with produce and nonperishables that are donated to The Sanctuary. The usage is dependent on the amount of food donated and put into the kiosk. When the kiosk is stocked with food, community members walk up to the kiosk, open the doors and take some of the food available inside.

### 2.1.6 Production Volume

A single abundant free food kiosk will be built for The Sanctuary and placed in front of the building with public access from the sidewalk.

## 2.2 Literature Review

### 2.2.1 Introduction

The purpose of the Literature Review section is to provide background information on public free food kiosks. The research conducted by The A-Team will be used in order to effectively design an abundant free food kiosk for the client *The Sanctuary*.

### 2.2.2 Client Interview

After a visitation to the Sanctuary in Arcata on September 23rd, 2016, the project for the abundant free food kiosk was clarified and able to undergo the design process. Mark Dubrow, a volunteer of The Sanctuary who is overseeing the project, provided information on what his ideas of the kiosk are and how The A Team should go about designing the project. The objective for the design is so people who walk by the kiosk can easily access the free food put inside of it.

### 2.2.3 Criteria

A 6x2x2 foot cabinet-like figure will be built on a stand where it will be raised to the sidewalk level. It is ideal for there to be a way for people to see inside through either a small window or clear doors. The location on the kiosk was decided to be on the east side of the building parallel to J Street, in an area where there is a brick surface about 4 feet below the surface of the sidewalk, allowing it to be propped up with a stand. Because the location was set to be on the side with sun hitting it for several hours a day, methods of cooling and insulation need to be implemented to keep certain food put inside from going bad quickly. This will include some sort of awning or roof to shade the kiosk, as well as to protect it from the rain, and a non-mechanical cooling section. The food placed inside will go in two compartments: one with a cooling capability and one without. There will also be two sets of doors for accessibility: one for the people at The Sanctuary to place the food in and one for the people on the sidewalk to reach in and grab the food. The food that will be put inside will remain there until it begins to go bad, where it will then be moved to the on-site compost bin or until community members take it. Since food will be inside for days at a time, the design needs to include a way to protect the food from flies and all sorts of critters. (Jessica Horton, personal 2016).

## 2.2.4 Examples and Methods

### 2.2.4.1 Little Free Pantry

In May 2016, an outdoor food storage cabinet was built and stocked with nonperishable goods in Fayetteville, Arkansas. This food cupboard is called the “Little Free Pantry” or LFP for short. In this community, the LFP was built so that people in desperate need of food have a place to get food. The LFP allows other community members to stock the cabinet themselves if they have extra nonperishables. Some of the items put inside of the LFP can be seen in Figure 2-1 below. Since the construction of the first LFP, many other community members have been building their own LFP around the nation. Some of those examples can be viewed at <https://www.facebook.com/littlefreepantry/>.



Figure 2-1 The original Little Free Pantry (LFP) (<https://www.facebook.com/littlefreepantry/>)

Items other than food are sometimes stored in the LFP. For example, on the last day of school, the project leader, Jessica McClard, puts fun little toys like jump ropes and sidewalk chalk that the kids of the community can play with. When school is starting up in August, community members and Jessica McClard put school supplies in the LFP such as pencils, erasers and paper.

The LFP was built in a safe neighborhood with little traffic and low crime rates. The builders of the LFP modeled their structure after the Little Free Library book kiosks that can sometimes be found in communities giving away free books. The LFP is a simple 4’x4’ cabinet with various shelves and compartments. It has a slanted shingle roof and a clear door where the contents of the pantry can be accessed by the public. To secure the structure, the LFP is bolted to a 4’x4’

piece of wood which is then cemented to the ground. The LFP does not store perishable food such as fruits and vegetables.

#### 2.2.4.2 Little Free Library

Another example of a free community kiosk is the Little Free Libraries (LFL) that can be found in some communities. These structures are containers that store books. Community members can come by and take or borrow the books inside of the LFL. Donations of new or gently used books are accepted to be put inside the libraries.

These structures are equipped with a slanted roof and are waterproof to protect the books from rain or snow. The door is absent of cracks around the edges to prevent water from entering the library through the door. Prepackaged LFLs are available to purchase or one can choose to create their own LFL. A video giving directions of how to set up a purchased Little Free Library can be viewed at <https://littlefreelibrary.org/build/> (Little Free Libraries, 2016).

#### 2.2.4.3 Paleta Cart

Jay Gordon in San Marcos, Texas built a paleta cart for the company Absolut. A paleta is a Mexican popsicle that is made from real fruit and fruit juice. Jay first created a metal frame and used cardboard circles to picture where the wheels would go. These cardboard wheels were replaced with actual bike wheels later in the design process. The paleta cart frame was then covered with an insulating material to keep the paletas cold on hot days and compartments were added. It was then decorated and the finishing touches were added as seen in Figures 2-2 through 2-5 below.



Figure 2-2 Paleta cart frame with cardboard wheels, a prototype



Figure 2-3 Paleta cart frame with real wheels



Figure 2-4 Paleta cart with insulation and outer walls

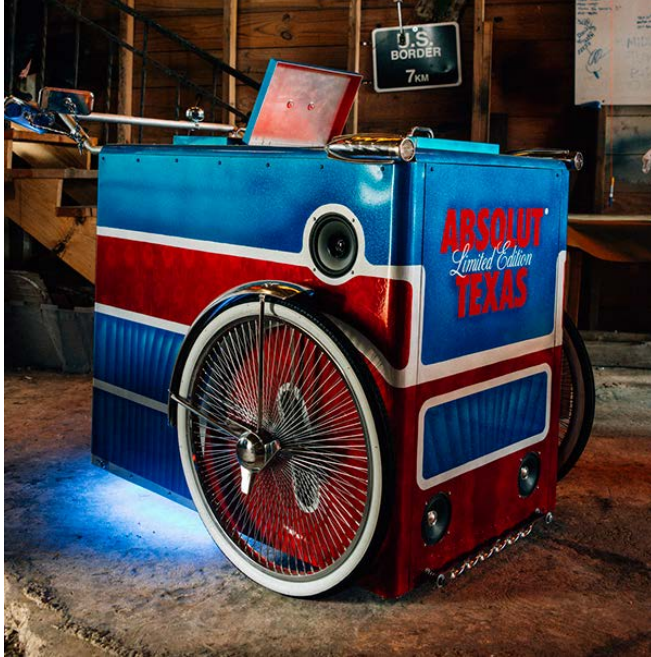

Figure 2-5 Final Paleta cart with designs

#### 2.2.4.4 Nanma Maram

A woman named Pauline, who owns a restaurant in India, had been noticing that at the end of the day, homeless people coming by and rifling through the restaurant's garbage cans in hopes of finding leftover food to eat. In early 2016, she opened a second location of her restaurant and this time, she placed a small refrigerator outside where she put the leftovers from the restaurant as seen below in Figure 2-6. This allows the homeless population to get clean food out of the refrigerator when they are hungry. Other patrons are encouraged to place extra food, marked with the date, in the refrigerator as well. Pauline encourages people not to buy extra food to put in the refrigerator but to simply put their leftovers into it. Pauline pushes this because, according to the UN Environmental Programme, 33 percent of food produced with the intention of human consumption is wasted while in India, 40 percent of food goes bad before it can be consumed (BBC, 2014). Pauline wants to combat this issue in India. This was her inspiration to put out this refrigerator for leftover food (Eric March, 2016).



Figure 2-6 The refrigerator that Pauline placed outside of her restaurant

## 2.2.5 Heating and cooling methods

### 2.2.5.1 *What is passive solar design*

Passive solar design is the process of utilizing the sun's UV rays to collect and store heat in a container. Outdoor bearing walls and windows can also utilize passive solar design by keeping heat out, as well as collecting it and keeping it in (Sustainable Sources). Utilizing passive solar design for heating or cooling a structure is much more energy efficient than using some other heating and cooling methods. Structures utilizing passive solar heat store the heat in the form of thermal mass (which is discussed later in the analysis) (U.S. Department of Energy).

#### 2.2.5.1.1 *Criteria*

When choosing a site for a structure to be built using passive solar design, a couple factors need to be considered. If the goal is to cool the structure, a site in direct sunlight will make it harder to cool the structure. If the goal is to heat the structure, a site in the shade will make it harder to be heated. The climate that the structure resides in plays a big role in how efficient passive solar design can heat or cool the structure (Judy Fosdick, Tierra Concrete Homes, 2012). If, for example, a home is built in a climate where it is very snowy and cloudy, it won't be very efficient in warming the house because of the lack of UV rays. If a home is built in a desert with no shade, it won't be very efficient in cooling the house because direct sunlight will be hitting the structure for most of the day. Another aspect to keep in mind to ensure efficiency is that the windows are placed properly. It is best if windows face 30 degrees south with little to no shade when it is desired that the structure be heated. The heating "season" of each day is said to be between nine o'clock am and three o'clock pm. When it is desired that the structure is cooled, shade by the windows will aid in cooling and prevent overheating in the hottest months of the year (U.S. Department of Energy).

#### 2.2.5.1.2 *How it works*

Passive solar heating works in a couple of different ways. Passive solar heating can heat something through conduction, which is heat passing between two objects that are touching each other. It can heat through convection, which is heat passing through air or water. Passive solar heating can also heat through radiation, which is when different types of materials put off different amounts of heat that they have absorbed (Sustainable Sources). Conduction, convection and radiation are explained in more detail later in the analysis.

#### 2.2.5.2 *Types of heating/cooling*

When designing a structure using passive solar design, insulation, ventilation, air flow, window placement and different types of heating and cooling are all factors that need to be taken into consideration. These factors play a role in which type of heating or cooling is achieved. In direct gain solar heating, sun that directly enters through a window is absorbed by other materials inside the structure. Those materials radiate the heat back into the structure when it is cooling down or no longer receiving direct sunlight. Some examples of materials that can store this solar heat are materials made of stone, wood containers filled with water or other materials. Indirect gain allows heat to be captured in a medium, such as a trombe wall for example, and radiated into the structure more slowly. Figure 2-7 below shows how a trombe wall works.

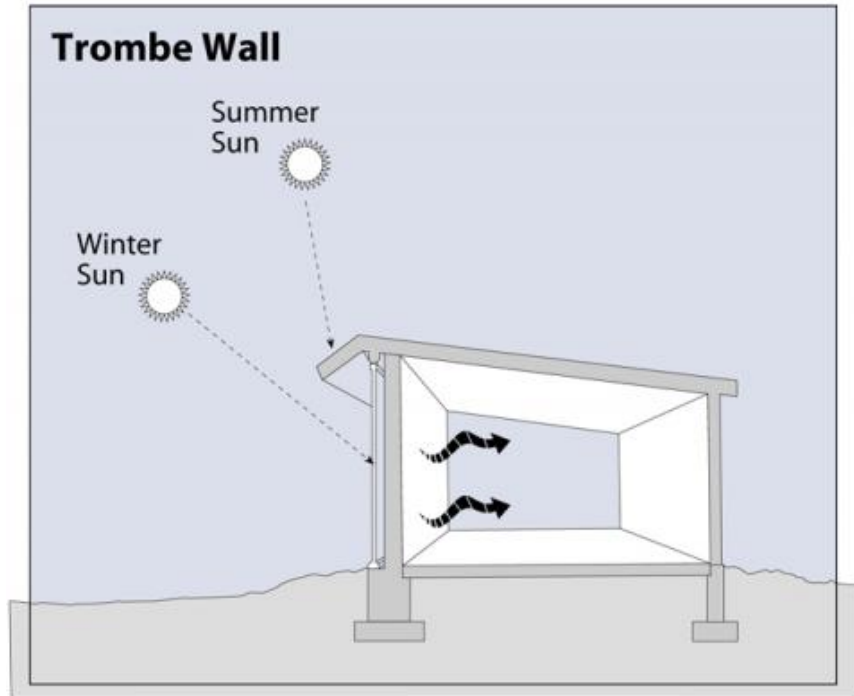

Figure 2-7 A trombe wall using indirect gain to heat an enclosed space

Isolated gain is also a type of passive solar heating. In isolated gain, a separate, closed off space, is built onto the structure. This separated, closed off space has many windows that the sun's UV rays can enter and warm the room. An example of this kind of heating is a sunroom, solar room or a solarium (U.S. Department of Energy).

## 2.2.6 The reuse of materials

### 2.2.6.1 What is upcycling?

Upcycling is the process of taking old, used or recycled materials and using them to make new objects of equal or greater value. Upcycled materials are often used in making art. The process of using upcycled materials originated in Germany in 1996 when Gunter Pauli wrote a book titled Upcycling (Transition Town Payson, 2013). Upcycling is becoming a more popular means of creating new things from recycled materials. The sale of upcycled products has been increasing since 2010 (OMICS, 2014).

### 2.2.6.2 Recycling

Recycling is the process of making something new from materials that have been used before and that can be broken down and cleaned (Webster's New Dictionary, 1984). Downcycling is the opposite of upcycling. Together, upcycling and downcycling make up the complete process of recycling. In downcycling, materials are reused but to make new things of equal or lesser value than the recycled parts used to build them (OMICS International, 2014).

### 2.2.6.3 Examples of upcycled and recycled materials

Since the process of upcycling has become more popular in recent years many objects and structures seen in anyone's day to day life may be an example of upcycling. Any material that

can be recycled can be upcycled as well. This includes (but is not limited to): cardboard, cooking oil, electronics, batteries, paper, glass, textiles and wood. On the other hand, many things that cannot be recycled, such as styrofoam, can be upcycled. Many artists use styrofoam in their art projects; art projects made of recycled materials is a type of upcycling. Some examples of projects built or created using upcycling are: consumer electronics, orthodox musical instruments, unique musical instruments, various art projects, some brewing processes, carbon nanotubes using plastic waste and animal feed using unsellable organic byproducts (OMICS International, 2014).

## 2.2.7 California food laws

### 2.2.7.1 Storage of food

Food storage areas should be clean at all times. If a food is not refrigerated, it must be kept dry and stored above ground on shelves or racks which can be easily cleaned. A room in which the food is stored in must be able to be ventilated and not be prone to any sort of contamination. Readily perishable foods must be stored at temperatures of 70 degrees Celsius (45 F) or below, and 60 degrees Celsius (140 F) or above, unless during times of preparation. For frozen foods, temperatures must be maintained at 18 degrees C (0 F) or below. For walk in refrigerators, food must be stored above ground on shelves or racks for easy cleaning. ([Barclays Official California Code of Regulations](#))

### 2.2.7.2 Distribution of food

Under section 114433 in the California Health and Safety Code, no food facility that donates to nonprofit organizations will be subject to criminal or civil liability for violation of any laws regarding the labeling or packaging of donated food after the time of donation. ([California Department of Public Health](#))

Under the Bill Emerson Food Donation Act, a non-profit organization is not responsible for the food received as a donation in good faith for needy individuals. The only exception of the act becomes an injury or death occurs from an act of omission, gross negligence, or intentional misconduct from the non-profit organization. This law encourages the donation of food to nonprofit organizations for its distribution purposes. ([Public Law 104-210, 104th Congress](#))

## 2.2.8 Heat capacity

Different materials contain different heat capacities and each material requires a specific amount of heat (energy) to alter its overall temperature. The equation,  $q=C_p*m*dT$  determines the heat required to increase a material's temperature according to its current conditions by using heat capacity specific to the material. ([The Engineering Toolbox](#))

## 2.2.9 Thermal conduction

Thermal conductivity can be described as the quantity of heat able to be transferred through a material of a certain thickness. Like a material's heat capacity, its conductivity per unit area can also be measured by an equation,  $q/A=k*dT/s$ , where the variable k serves as the thermal conductivity specific to the material. A material's thermal conductivity varies with its density, moisture content, and temperature. Different conditions affect these levels where the thickness of

the material(s) and the area of the material determine its ability to transfer heat. ([The Engineering Toolbox](#))

#### 2.2.10 Insulation

Insulation provides a resistance to heat flow, where the materials used to line another material prevent heat from seeping into or out of a specific area. Heat flows from the warmer temperatures to the cooler until no temperature differences exist, making the insulation delay the heat flow to keep a space cooler for a longer period of time. Different types of insulation include fiberglass, mineral wool, plastic fibers, foam boards, natural fibers and more. The effectiveness of insulation also depends on where and how it was installed, as well as the surrounding temperature and climate. ([Energy.gov](#))

#### 2.2.11 Heat's effect on food

Bacteria grows fastest in 40-140 degrees Fahrenheit, and can double their numbers within 20 minutes. Especially in temperatures over 90 F, food should not be left out more than one hour. Refrigerated foods will eventually spoil at temperatures of 40 F, where foods may grow mold and cause food-borne illnesses. ([USDA](#))

#### 2.2.12 Solar radiation (Arcata)

Yearly temperatures in Arcata averages at about 50 degrees Fahrenheit, with highs and lows remaining in the 50's and 40's. July, August, and September stand as the hottest months while January and February remain the coldest. ([NOAA \(National Oceanic and Atmospheric\)](#))

The solar radiation levels Arcata received from September of 2015 to September of 2016 measures out between 350(low) and 1200(high) Watts per meter squared ( $W/m^2$ ). These levels were measured from Humboldt State University, and demonstrate a peak in levels from 10:00 am to 3:00 pm daily. ([NREL](#))

#### 2.2.13 Refrigeration

##### 2.2.13.1 Introduction

In the construction of a food storage unit, it is important to have a form of refrigeration to ensure food preservation. This section will outline and describe various methods for food refrigeration, and provide appropriate background for each.

##### 2.2.13.1.1 Zeer Pots

The Zeer Pot technique is one that provides refrigeration through a natural, environment friendly design. This food preservative system was created with the main intention of helping farmers in harsh dry climates preserve their agricultural produce. It has since become an easy way for underdeveloped countries and rural regions to cater to their food preservation needs using indigenously available materials. Due to the Zeer Pot's reliance on natural evaporative cooling, the success of the refrigeration method is heavily dependent on the surrounding conditions. Thus, it is most efficient in regions that demonstrate a suitably low relative humidity and a sufficient level of air flow (R 2016).

The Zeer Pot design is illustrated in Figure 2-8. This design involves placing a clay pot into a larger clay pot, surrounding the gap in between the two pots with sand, and then pouring cold

water into the sand, where the voids present in the sand act as a medium to retain the water required for evaporative cooling. The food that is wished to be preserved is placed inside the smaller of the two pots. Experiments have also shown the use of charcoal and gunny cloth to be effective alternatives to using sand (R 2016).

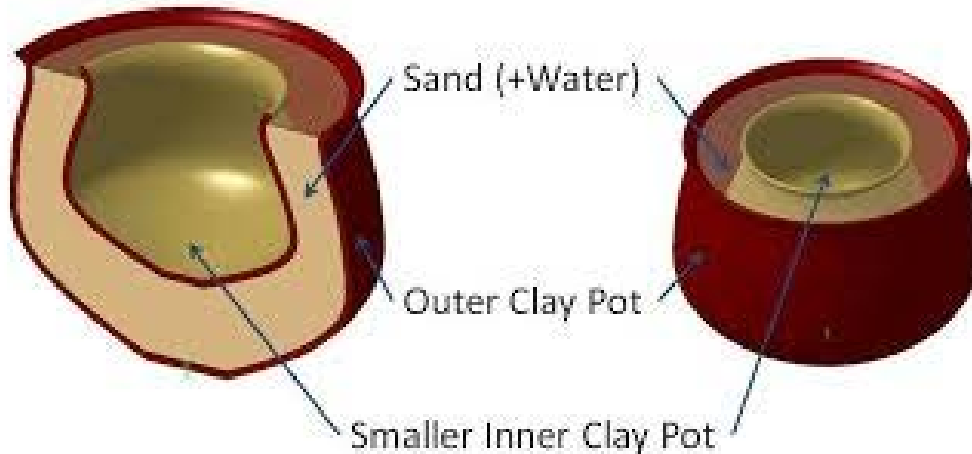

Figure 2-8 Zeer pot design with cross-section (R 2016)

Because it is porous (full of pores), the outer clay pot allows water to pass through it by hydraulic conductivity. After passing through the pot and arriving on the outer surface, the water will be exposed to the surrounding air. The hidden heat of evaporation energy required is observed from the inner pot; thus, the water, by evaporating, cools the inner pot area and brings about refrigeration for the stored food (R 2016).

#### 2.2.13.1.2 Solar powered refrigeration

Solar refrigeration technology is relatively modern, and introduces a category all on its own containing a myriad of technical approaches for refrigeration. This section will briefly cover three of these different solar approaches: 1) Vapor Compression Refrigeration, 2) Solar Mechanical Refrigeration, and 3) Absorption Refrigeration.

#### 2.2.13.1.3 Vapor compression refrigeration

A representation of the vapor compression cycle can be seen in Figure 2-9. In this type of refrigeration system, cooling is provided in the evaporator. A mixture of liquid and vapor at State 4 is vaporized by thermal input from the load; this in turn is used as the low temperature refrigerant that enters the evaporator. The vapor exiting the evaporator at State 1 then enters the compressor, a mechanism that raises the pressure and thus the overall temperature of the refrigerant. This high pressured, hot refrigerant then enters a condenser at State 2; the condenser uses existing air or water to cool the refrigerant back to its saturation temperature, the temperature that produces the most wetness. The refrigerant fully condenses into a liquid at State 3 and is then throttled to a lower pressure; this causes some of the refrigerant to vaporize as its temperature is reduced. The low temperature liquid that remains is available to produce useful refrigeration (Klein and Reindl 2005).

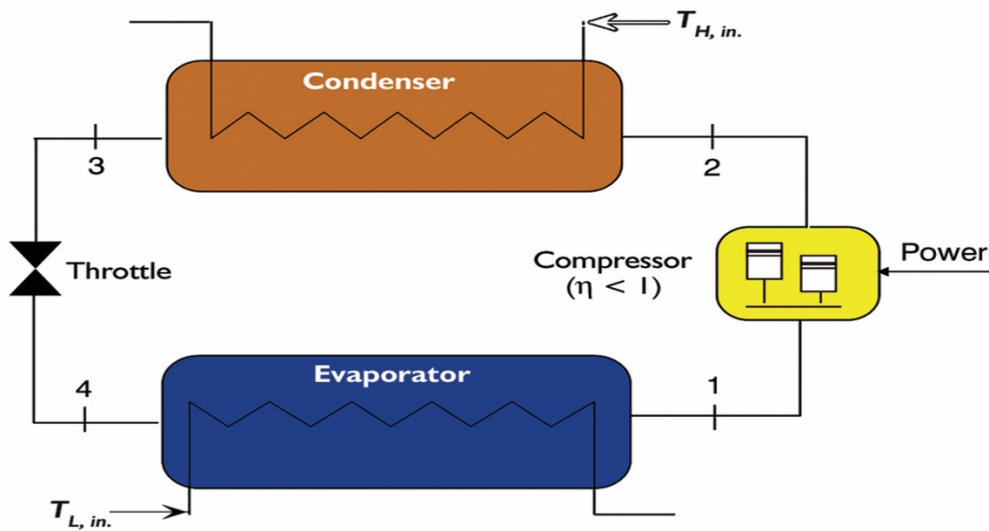

Figure 2-9 Schematic of a vapor compression refrigeration system (Klein and Reindl 2005)

#### 2.2.13.1.4 Solar mechanical refrigeration

A representation of the solar mechanical power cycle can be seen in Figure 2-10. This type of refrigeration system combines the use of a vapor compression system and a solar-driven heat power cycle, such as a Rankine cycle. In a Rankine cycle, a fluid is vaporized at an elevated pressure by exchanging heat with a fluid that has been heated by solar collectors. A storage tank, as illustrated in Figure 2-10, can be included to provide some high temperature thermal storage. The other elements illustrated in Figure 2-10 are those associated with the vapor compression part of the system (Klein and Reindl 2005).

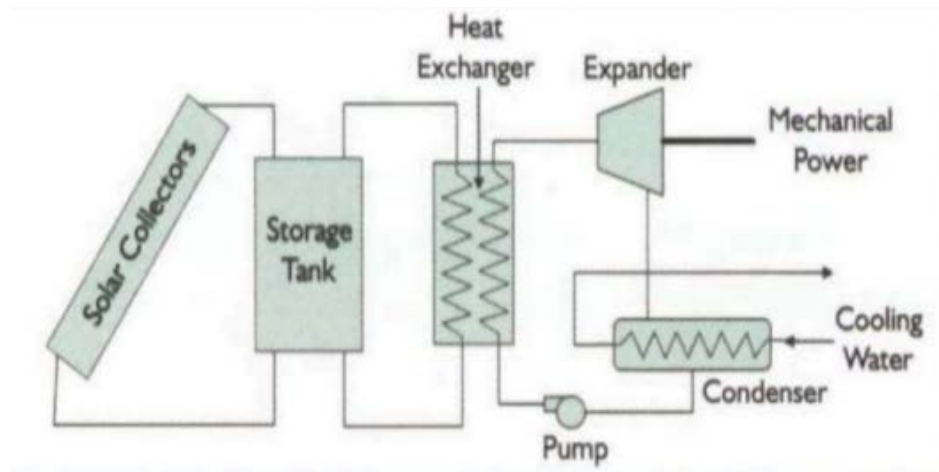

Figure 2-10 Schematic of a solar driven mechanical power cycle (Klein and Reindl 2005)

#### 2.2.13.1.5 Absorption refrigeration

The absorption refrigeration system—which is considered a heat-driven system—requires minimal mechanical power for the compression process. This system replaces the energy-

intensive compression in a vapor compression system with a heat-activated thermal compression system. Figure 2-11 provides a representation of a single-stage absorption system that uses ammonia as the refrigerant and ammonia-water as the absorbent (Klein and Reindl 2005).

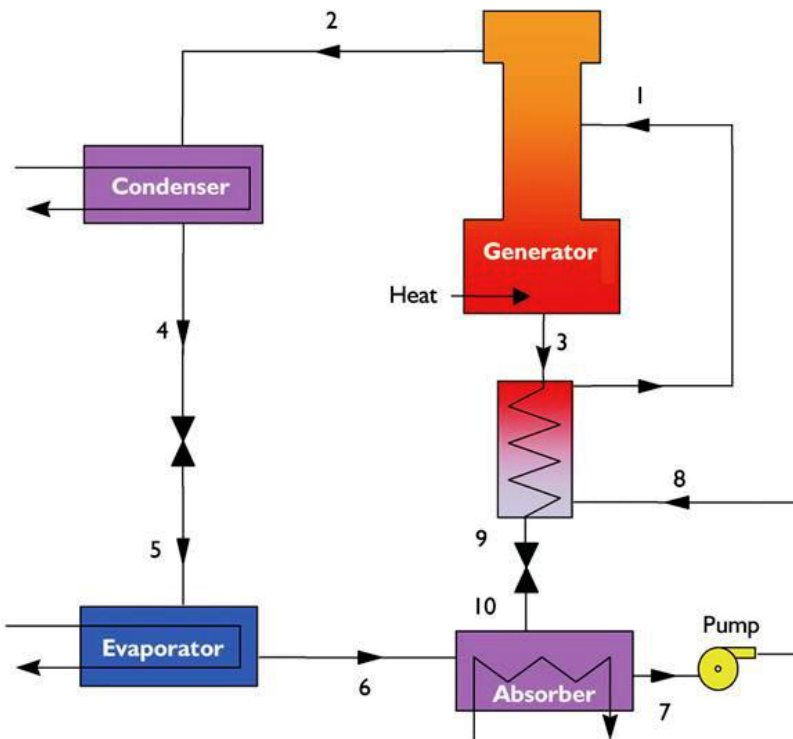

Figure 2-11 Schematic of an ammonia-water absorption refrigeration system (Klein and Reindl 2005)

## 2.2.14 Accessibility

### 2.2.14.1 Introduction

To maximize the impact of the free food distribution system, the unit will be placed outside near the sidewalk where it will be made easily accessible to those needing of it. Although it increases the level of accessibility for the target audience, the location of the unit also makes it a greater target for wildlife, such as rodents, raccoons and insects. The following sections will provide some background on how to address each of these potential threats in the construction of our free food distribution system.

#### 2.2.14.1.1 Rodent proof construction

In designing a rodent proof construction, it is important to consider the physical abilities of rodents. From this consideration one must consider the following as potential points of access (Baker):

- Holes and openings
- Vents and windows
- Foundations and floors

#### 2.2.14.1.2 Raccoon proof construction

“...raccoons show remarkable determination and ingenuity in their pursuit of a free lunch” (REI). For this reason, the following should be considered as potential prevention methods:

- Containers (material varies) with hinged, latched openings
- Hard-sided, secure-locking food containers

#### 2.2.14.1.3 Insect proof construction

To prevent insect infestation, the following are recommended (Emergency Outdoors):

- Keep all stored foods in tight, clean, metal, plastic, or glass containers with tight fitting lids and no open seams or crevices
- Store food off the floor and away from damp areas.

#### 2.2.15 Building materials for outdoors

##### 2.2.15.1 Hot dipped galvanized metal

Hot-dip galvanized metal is iron or steel sheets that have been dipped in molten zinc in order to create protection from corrosion of the metal base. The process of galvanizing metal has been around since 1837 and originated in France and England (GSA, 7/13/2016). Galvanized metals can prove useful when considering designing an outdoor structure that will be exposed to a wet environment. Rainfall in coastal areas can help reduce corrosion on galvanized metals by the washing affect it has on the metal (GAA, 2). In areas where the possibility of corrosion is high, using galvanized steel is recommended in order to preserve the steel. It is also important to ensure that the fasteners used on the connector plate is also galvanized steel because using different metals can sometimes be more likely to corrode (FEMA, 4).



Figure 2-12 A stack of galvanized steel sheets

#### 2.2.15.2 Wood

Wood, when building outside, can have advantages and disadvantages. One advantage is that you can cut wood yourself almost always into whatever size you want. One disadvantage to building with wood outside is that if not treated for properly your wood can deteriorate and rot. Wood has the advantage of drying out and becoming stronger when exposed to heat, in contrary to steel which expands when exposed to heat. Also, wood has a very high specific heat which means it takes a lot of energy to change the temperature of the wood which is good for maintaining temperatures (Ramazan ÖZEN). Although wood does deteriorate in different ways whether biologically or non-biologically, there are many ways to treat wood to prevent that from occurring. Some methods of preventing biological deterioration are coating, drying, and treatment with preservatives. In some cases, fire retardants can be added to wood to help reduce volatile flammable gasses (Ramazan ÖZEN).

#### 2.2.15.3 Aluminum

electrical conductivity, and is very soft. Aluminum is used for many different things, such as roofing, wall panels, and doors. Aluminum has high corrosion resistance with natural corrosion elements such as exposure to air, but it's corrosion resistance is low with chemical corrosion elements such as hydrochloric acid (GSA, 8/04/16). Aluminum forms a natural protective layer of oxide as soon as it is exposed to air. Many aluminum products however increase the oxide layer by up to 25 microns through a process called anodization (Rathi, Patil, 2.2). Some advantages to building with aluminum are that aluminum is easy to work with, it is non-combustible, and its durability offers performance for a long time. A disadvantage is that aluminum if being used for a roof may be difficult to waterproof (Rathi, Patil,3.1-3.2).

#### 2.2.15.4 Plexiglass

Plexiglass is an acrylic plastic sheet that is manufactured by *Altuglas International of Arkema Inc.* Plexiglas is a material that is high impact resistant, chemical resistant, with great weather ability (Plexiglas, 1). Plexiglas sheet has the greatest impact resistance of all types of glass. Most types of Plexiglas sheets have great resistance to chemicals such as ammonia and some hydrocarbons. Some types of Plexiglas, however, are not as resistant to inorganic compounds such as acetone and may dissolve (Plexiglas, 3). Plexiglas is commonly used as food storage or food display as well. It works well at displaying food because it is less shatter prone than glass, and has the same clear translucent color as glass.



*Figure 2-13 A Plexiglas food display box*

### 2.2.16 Awning

Awnings are outdoor covers used to protect a designated area from heat, rain, and other outdoor weather conditions. Window awnings can reduce heat increases during the summer by up to 77%. Awnings used to be made from metal or canvas but needed more consistent maintenance than today's awnings. Today awnings are made of synthetic materials like acrylic which are commonly water resistant (energy.gov).



*Figure 2-14 an example of an awning used in front of a bakery*

## 3 Alternative Solutions

### 3.1 Introduction

The A Team conducted three brainstorming sessions to develop twelve alternative solutions of The Abundant Free Food Kiosk. Figure 3-1 illustrates the base model that all the alternative solutions will follow. All the alternative solutions have the following aspects and options: 1) Alternative solutions are insulated, 2) Vents will be covered with mesh/filter/cloth, and 3) Doors have the option of being constructed from wood, Plexiglas, or metal. Alternative solutions were developed from research conducted in the literature review section, and follow the specifications and criteria found in the problem analysis section.

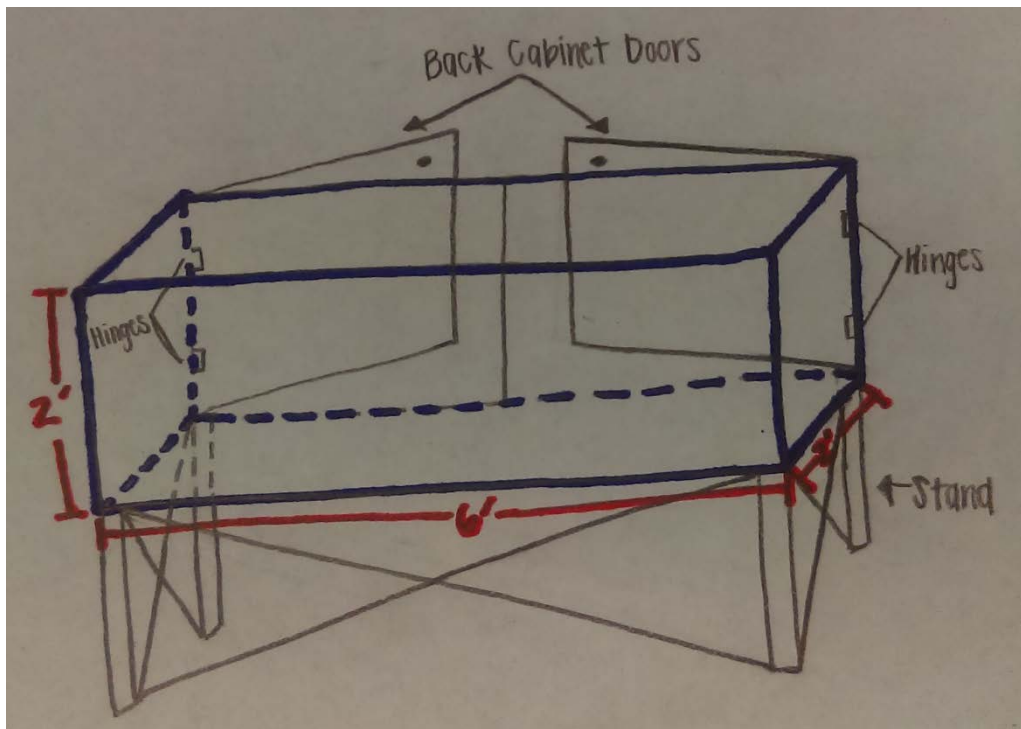

Figure 3-1 Base Model includes the set dimensions, stand, and back cabinet doors that will be used for all alternative solutions

### 3.2 Brainstorming

The A Team conducted three brainstorming sessions. The first brainstorming session was an unstructured brainstorming session in which all criticisms were avoided. During the first brainstorming session, we filled up half of a whiteboard with ideas for different aspects of the kiosk. The second brainstorming session was a structured brainstorming session where ideas were eliminated, combined, or altered. At the end of the second brainstorming session, we had compiled a list of all possible aspects of the kiosk. In the third brainstorming session, we created twelve alternatives using the compiled aspects list created in the second brainstorming session. Each of the twelve alternatives contained a different combination of aspects from the compiled aspects list. After the twelve alternatives were modified, they were divided amongst the four group members of the A Team.

### 3.3 The Cold Mailbox

Figure 3-2 illustrates The Cold Mailbox. The Cold Mailbox is a box that is split into two compartments, one with refrigeration and one without. The front of The Cold Mailbox (i.e., the side facing the street) has two mailbox doors; the back of The Cold Mailbox (i.e., the side facing the Sanctuary) has two cabinet doors. A slanted roof is placed above The Cold Mailbox as a cover.

The front mailbox doors pull downwards to access the food inside of the compartments; the mailbox doors are accessible to the community. The back-cabinet doors pull open to allow for the restocking of food; the cabinet doors are accessible only by the Sanctuary.

The compartment with refrigeration uses the chill box method of refrigeration. The chill box method of refrigeration relies on the cool air that flows through the chill box vent to decrease the temperature and humidity in the compartment. The chill box vent is located on the side of the compartment with refrigeration.

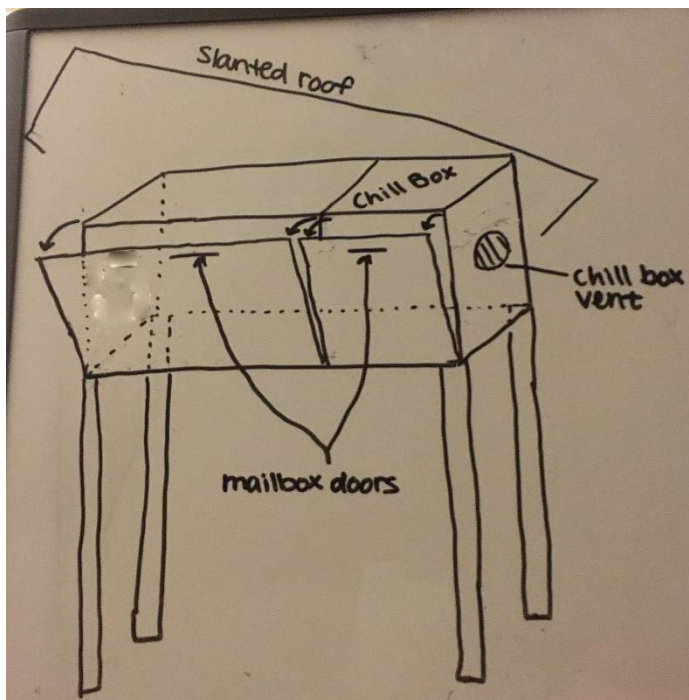

Figure 3-2 The Cold Mailbox is a two-compartment box that uses the chill box refrigeration method, has mailbox doors in the front, and has a slanted roof for cover. A vent is located on the side of the chill box compartment for ventilation.

### 3.4 The Zeer Box

Figure 3-3 illustrates The Zeer Box. The Zeer Box is a box that is split into two compartments, one with refrigeration and one without. The front of The Zeer Box (i.e., the side facing the street) has two mailbox doors; the back of The Zeer Box (i.e., the side facing the Sanctuary) has two cabinet doors. A slanted roof is placed above The Zeer Box as a cover.

The front mailbox doors pull downwards to access the food inside of the compartments; the mailbox doors are accessible to the community. The back-cabinet doors pull open to allow for the restocking of food; the cabinet doors are accessible only by the Sanctuary.

The compartment with refrigeration uses the zeer pot method of refrigeration. The zeer pot refrigeration method uses two zeer pots of different sizes, where the smaller of the two pots is placed inside the larger of the two pots and the gap between the two pots is surrounded with sand and filled with water. The compartment without refrigeration has a shelf that divides the height in half; the compartment shelf allows for better use of the storage space in the compartment. A vent is located on top of the compartment without refrigeration to reduce humidity and allow air flow; the placement of the compartment vent accounts for the rising of heat and ensures that the heat in the compartment that rises exits the compartment.

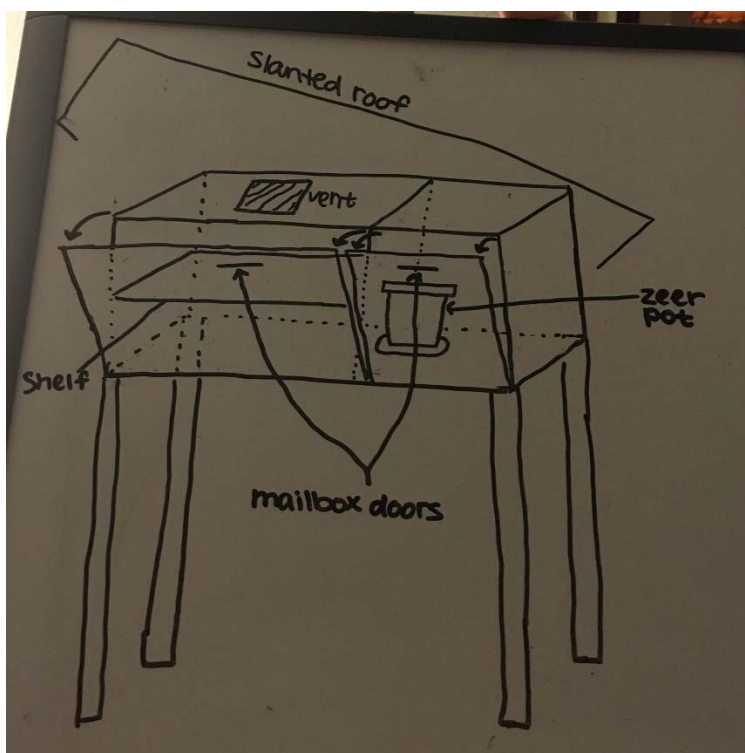

Figure 3-3 The Zeer Box is a two-compartment box that uses the zeer pot refrigeration method, has mailbox doors in the front, and has a slanted roof for cover. A vent is located on top of the compartment without refrigeration for ventilation.

### 3.5 The House Cabinet

Figure 3-4 illustrates The House Cabinet. The House Cabinet is a single unit box made without any method of refrigeration. The front of The House Cabinet (i.e., the side facing the street) has a single mailbox door; the back of The House Cabinet (i.e., the side facing the Sanctuary) has two cabinet doors. A triangle roof is placed above The House Cabinet as a cover.

The front mailbox door pulls downwards to access the food inside of the unit; the mailbox door is accessible to the community. The back-cabinet doors pull open to allow for the restocking of food; the cabinet doors are accessible only by the Sanctuary.

Vents are located on the top and side of the unit to reduce humidity and allow air flow. The side unit vent allows cool air to enter the unit, and the top unit vent accounts for the rising of heat and ensures that the heat that rises exits the unit. The unit has a shelf that divides the height in half; the unit shelf allows for better use of the storage space in the unit.

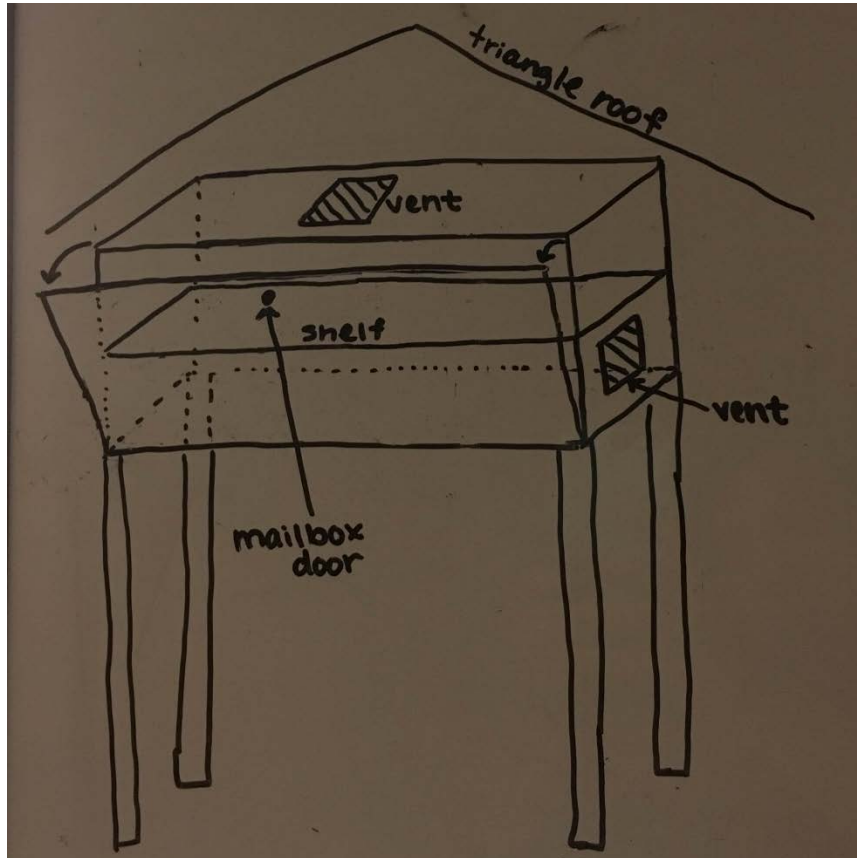

Figure 3-4 The House Cabinet is a single unit box that has a mailbox door in the front, a triangle roof for cover and no method of refrigeration. A vent is located on the top and side of the unit for ventilation.

### 3.6 The Chill Slider

Figure 3-5 illustrates The Chill Slider. The Chill Slider is a box that is split into two compartments, one with refrigeration and one without. The front of The Chill Slider (i.e., the side facing the street) has two sliding doors; the back of The Chill Slider (i.e., the side facing the Sanctuary) has two cabinet doors. A slanted roof is placed above The Chill Slider as a cover.

The front sliding doors slide to the side (i.e., the right door slides to the left and vice versa) to access the food inside of the compartments; the sliding doors are accessible to the community. The back-cabinet doors pull open to allow for the restocking of food; the cabinet doors are accessible only by the Sanctuary.

The compartment with refrigeration uses the chill box method of refrigeration. The chill box method of refrigeration relies on the cool air that flows through the chill box vent to decrease the temperature and humidity in the compartment. The chill box vent is located on the side of the compartment with refrigeration.

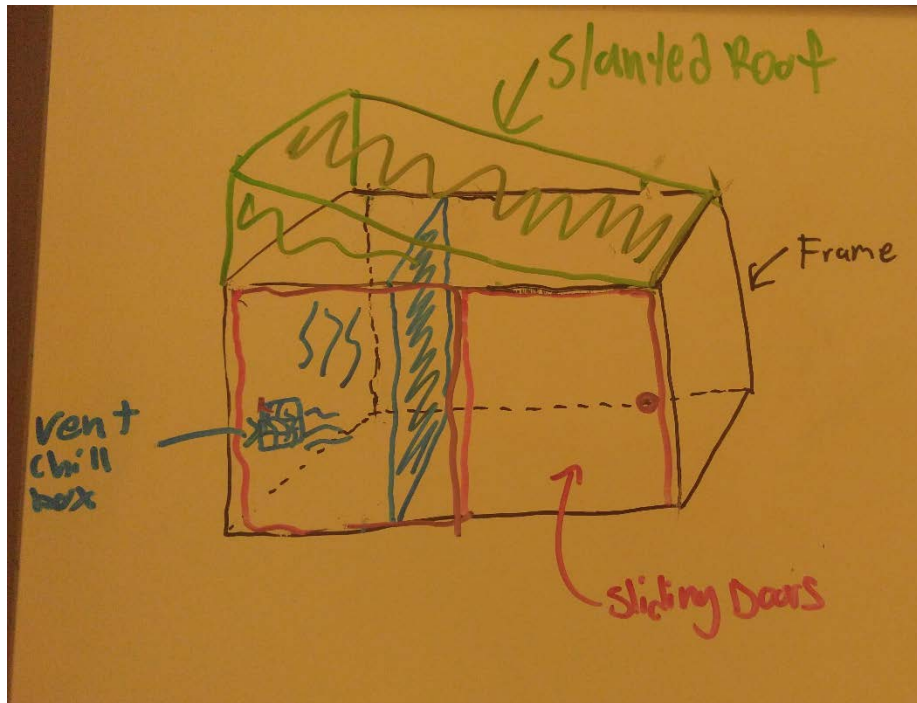

Figure 3-5 The Chill Slider is a two-compartment box that uses the chill box refrigeration method, has sliding doors in the front, and has a slanted roof for cover. A vent is located on the side of the chill box compartment for ventilation.

### 3.7 The Zeer Slider

Figure 3-6 illustrates The Zeer Slider. The Zeer Slider is a box that is split into two compartments, one with refrigeration and one without. The front of The Zeer Slider (i.e., the side facing the street) has two sliding doors; the back of The Zeer Slider (i.e., the side facing the Sanctuary) has two cabinet doors. A slanted roof is placed above The Zeer Slider as a cover.

The front sliding doors slide to the side (i.e., the right door slides to the left and vice versa) to access the food inside of the compartments; the sliding doors are accessible to the community. The back-cabinet doors pull open to allow for the restocking of food; the cabinet doors are accessible only by the Sanctuary.

The compartment with refrigeration uses the zeer pot method of refrigeration. The zeer pot refrigeration method uses two zeer pots of different sizes, where the smaller of the two pots is placed inside the larger of the two pots and the gap between the two pots is surrounded with sand and filled with water. The zeer pot method works through evaporative cooling and relies on low humidity and a sufficient level of air flow. A vent is located on top of the zeer pot compartment to reduce humidity and allow air flow; the placement of the compartment vent accounts for the rising of heat and ensures that the heat in the compartment that rises exits the compartment. The compartment without refrigeration has a shelf that divides the height in half; the compartment shelf allows for better use of the storage space in the compartment.

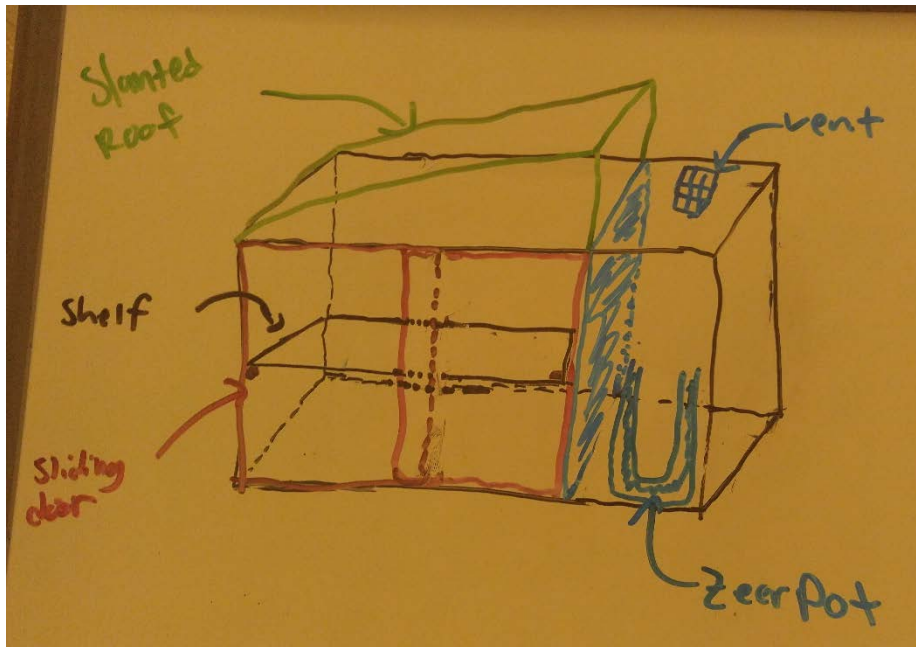

Figure 3-6 The Zeer Slider is a two-compartment box that uses the zeer pot refrigeration method, has sliding doors in the front, and has a slanted roof for cover. A vent is located on top of the zeer pot compartment for ventilation.

### 3.8 The Pyramid

Figure 3-7 illustrates The Pyramid. The Pyramid is a single unit box made without any method of refrigeration. The front of The Pyramid (i.e., the side facing the street) has two sliding doors; the back of The Pyramid (i.e., the side facing the Sanctuary) has two cabinet doors. A triangle roof is placed above The Pyramid as a cover.

The front sliding doors slide to the side (i.e., the right door slides to the left and vice versa) to access the food inside of the compartments; the sliding doors are accessible to the community. The back-cabinet doors pull open to allow for the restocking of food; the cabinet doors are accessible only by the Sanctuary.

Vents are located on both sides of the unit to reduce humidity and allow air flow. The lower side-vent allows cool air to enter the unit, and the upper side-vent accounts for the rising of heat and ensures that the heat that rises exits the unit. The unit does not have a shelf; the absence of a shelf allows food to be hung if necessary.

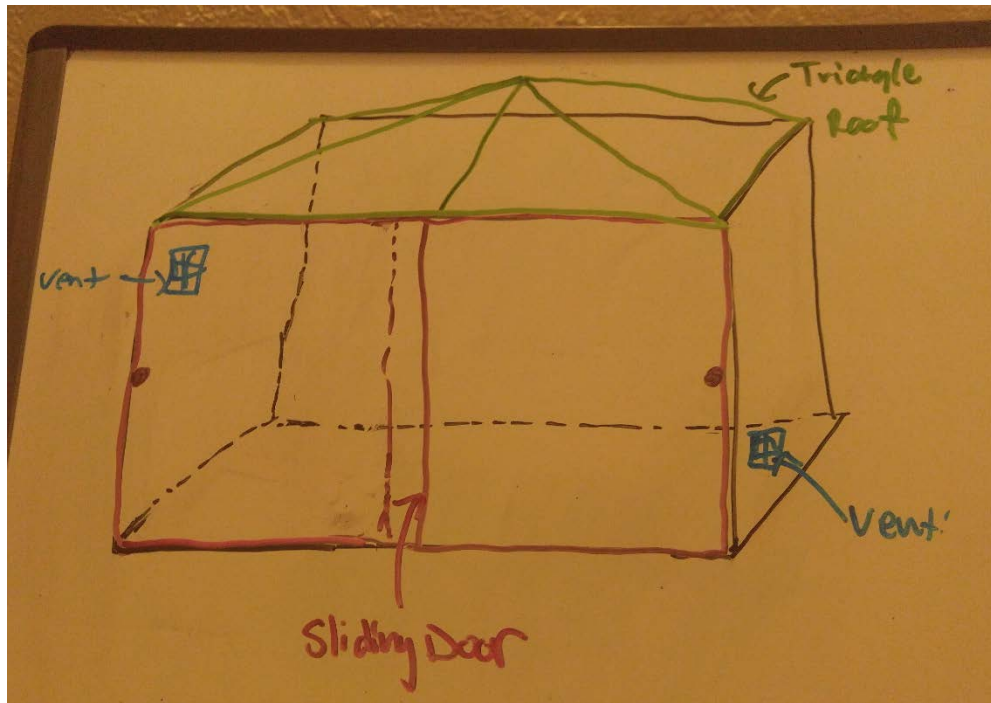

Figure 3-7 The Pyramid is a single unit box that has a sliding door in the front, a triangle roof for cover and no method of refrigeration. A vent is located on both sides of the unit for ventilation.

### 3.9 The Kool Cabinet

Figure 3-8 illustrates The Kool Kabinet. The Kool Kabinet is a box that is split into two compartments, one with refrigeration and one without. The front of The Kool Kabinet (i.e., the side facing the street) has two cabinet doors, as does the back of the Kool Kabinet (i.e., the side facing the Sanctuary). A slanted roof is placed above The Kool Kabinet as a cover.

The front cabinet doors pull open to access the food inside of the compartments; the front doors are accessible to the community. The back-cabinet doors also pull open and allow for the restocking of food; the back doors are accessible only by the Sanctuary.

The compartment with refrigeration uses the chill box method of refrigeration. The chill box method of refrigeration relies on the cool air that flows through the chill box vent to decrease the temperature and humidity in the compartment. The chill box vent is located on the side of the compartment with refrigeration.

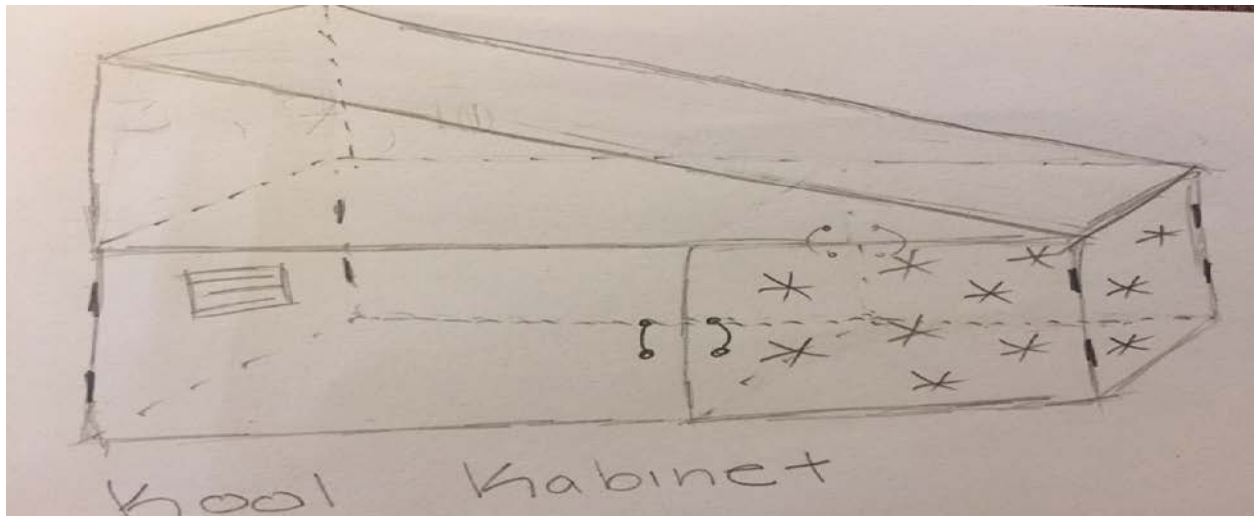

Figure 3-8 The Kool Kabinet is a two-compartment box that uses the chill box refrigeration method, has cabinet doors in the front, and has a slanted roof for cover. A vent is located on the side of the chill box compartment for ventilation.

### 3.10 The Terra Cottage

Figure 3-9 illustrates The Terra Cottage. The Terra Cottage is a box that is split into two compartments, one with refrigeration and one without. The front of The Terra Cottage (i.e., the side facing the street) has two cabinet doors, as does the back of The Terra Cottage (i.e., the side facing the Sanctuary). A triangle roof is placed above The Terra Cottage as a cover.

The front cabinet doors pull open to access the food inside of the compartments; the front doors are accessible to the community. The back-cabinet doors also pull open and allow for the restocking of food; the back doors are accessible only by the Sanctuary.

The compartment with refrigeration uses the zeer pot method of refrigeration. The zeer pot refrigeration method uses two zeer pots of different sizes, where the smaller of the two pots is placed inside the larger of the two pots and the gap between the two pots is surrounded with sand and filled with water. The compartment without refrigeration has a shelf that divides the height in half; the compartment shelf allows for better use of the storage space in the compartment. A vent is located on top of the compartment without refrigeration to reduce humidity and allow air flow; the placement of the compartment vent accounts for the rising of heat and ensures that the heat in the compartment that rises exits the compartment.

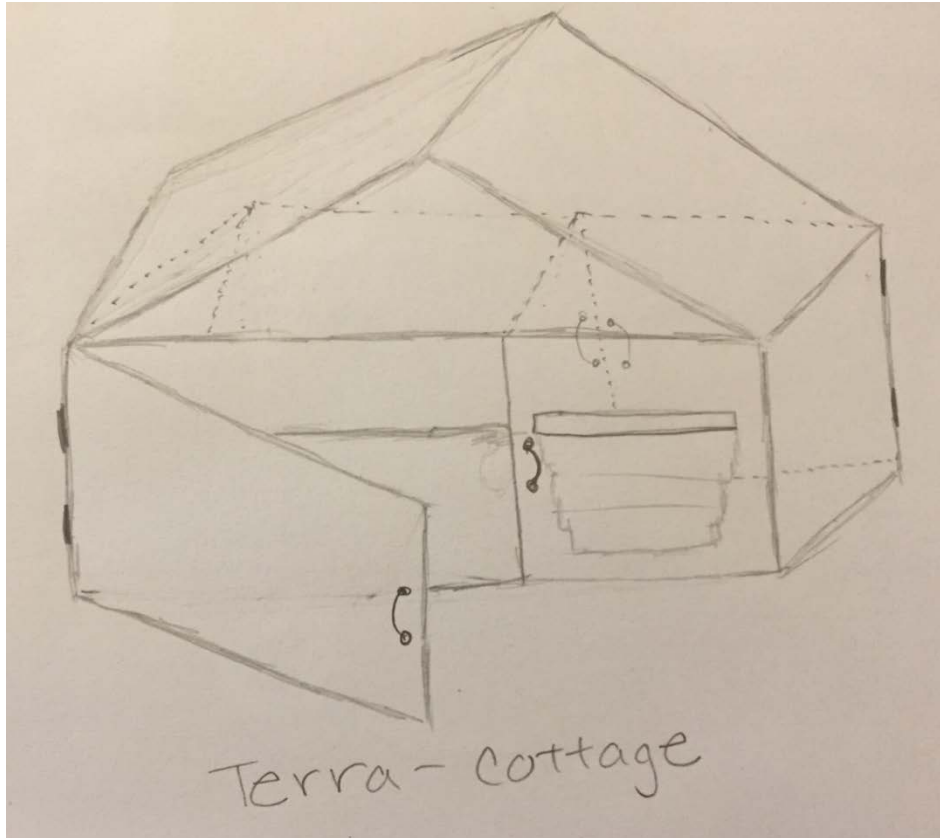

*Figure 3-9 The Terra Cottage is a two-compartment box that uses the zeer pot refrigeration method, has cabinet doors in the front, and has a triangle roof for cover. A vent is located on top of the zeer pot compartment for ventilation.*

### 3.11 The Hot Shelf

Figure 3-10 illustrates The Hot Shelf. The Hot Shelf is a box that is split into two compartments and is without any method of refrigeration. The front of The Hot Shelf (i.e., the side facing the street) has two cabinet doors, as does the back of The Hot Shelf (i.e., the side facing the Sanctuary). A triangle roof is placed above The Hot Shelf as a cover.

The front cabinet doors pull open to access the food inside of the compartments; the front doors are accessible to the community. The back-cabinet doors also pull open and allow for the restocking of food; the back doors are accessible only by the Sanctuary.

Vents are located on the sides of both compartments to reduce humidity and allow air flow. The lower side-vent allows cool air to enter the unit, and the upper side-vent accounts for the rising of heat and ensures that the heat that rises exits the unit. Each compartment includes two shelves that divide the height in three; the shelves allow for better use of the storage space in the compartments.

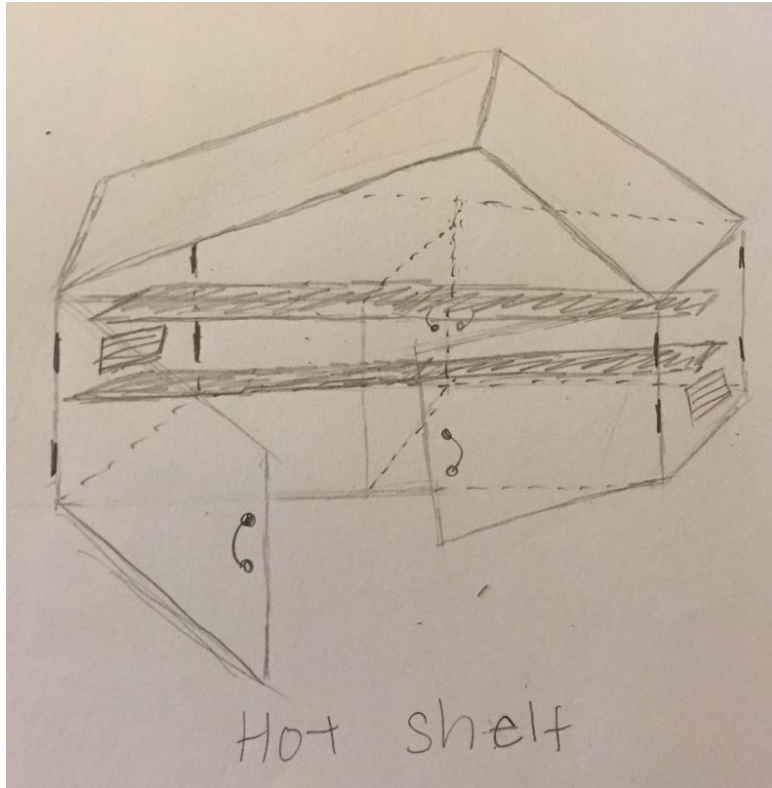

*Figure 3-10 The Hot Shelf is a two-compartment box that has cabinet doors in the front, a triangle roof for cover and no method of refrigeration. A vent is located on the both sides of the unit for ventilation*

### 3.12 The Chill Hatch

Figure 3-11 illustrates The Chill Hatch. The Chill Hatch is a box that is split into two compartments, one with refrigeration and one without. The front of The Chill Hatch (i.e., the side facing the street) has two hatch doors; the back of The Chill Hatch (i.e., the side facing the Sanctuary) has two cabinet doors. A slanted roof is placed above The Chill Hatch as a cover.

The front hatch doors pull upwards to access the food inside of the compartments; the hatch doors are accessible to the community. The back-cabinet doors pull open to allow for the restocking of food; the cabinet doors are accessible only by the Sanctuary.

The compartment with refrigeration uses the chill box method of refrigeration. The chill box method of refrigeration relies on the cool air that flows through the chill box vent to decrease the temperature and humidity in the compartment. The chill box vent is located on the side of the compartment with refrigeration.

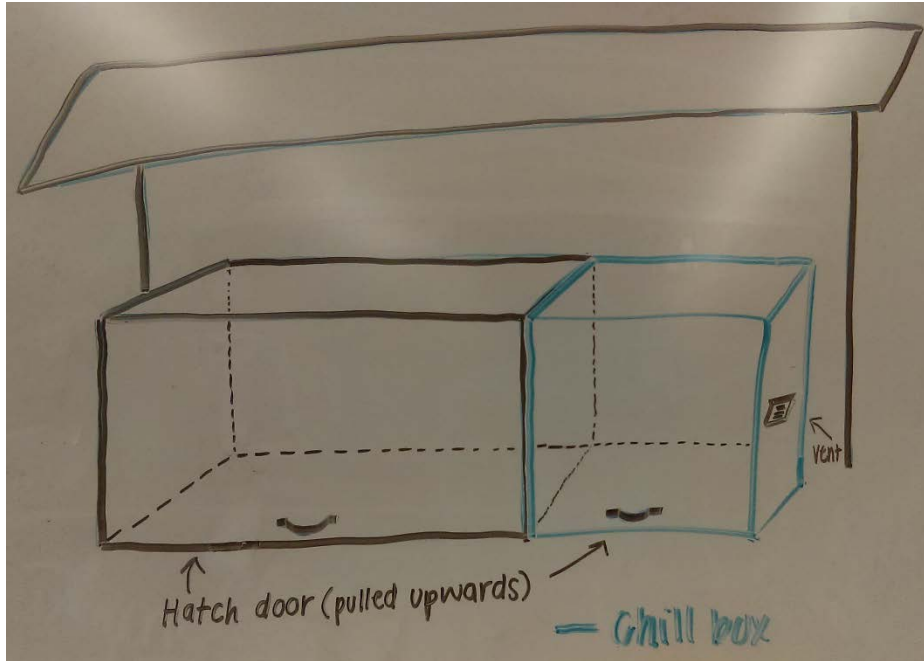

Figure 3-11 The Chill Hatch is a two-compartment box that uses the chill box refrigeration method, has hatch doors in the front, and has a slanted roof for cover. A vent is located on the side of the chill box compartment for ventilation.

### 3.13 Pot o' Gold

Figure 3-12 illustrates Pot o' Gold. Pot o' Gold is a box that is split into two compartments, one with refrigeration and one without. The front of Pot o' Gold (i.e., the side facing the street) has two hatch doors; the back of Pot o' Gold (i.e., the side facing the Sanctuary) has two cabinet doors. A triangle roof is placed above Pot o' Gold as a cover.

The front hatch doors pull upwards to access the food inside of the compartments; the hatch doors are accessible to the community. The back-cabinet doors pull open to allow for the restocking of food; the cabinet doors are accessible only by the Sanctuary.

The compartment with refrigeration uses the zeer pot method of refrigeration. The zeer pot refrigeration method uses two zeer pots of different sizes, where the smaller of the two pots is placed inside the larger of the two pots and the gap between the two pots is surrounded with sand and filled with water. The zeer pot method works through evaporative cooling and relies on low humidity and a sufficient level of air flow. Vents are located on top of both compartments to reduce humidity and allow for air flow; the placement of the compartment vents accounts for the rising of heat and ensures that the heat in the compartment that rises exits the compartment. The compartment without refrigeration has a shelf that divides the height in half; the compartment shelf allows for better use of the storage space in the compartment.

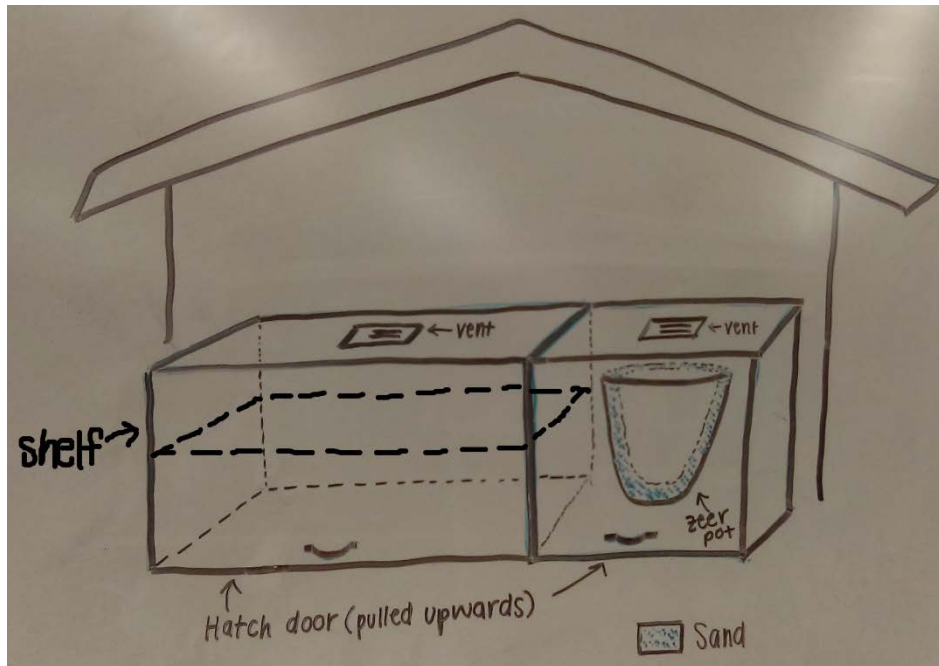

Figure 3-12 Pot o' Gold is a two-compartment box that uses the zeer pot refrigeration method, has hatch doors in the front, and has a triangle roof for cover. A vent is located on top of both compartments for ventilation.

### 3.14 The No Chill Hatch

Figure 3-13 illustrates The No Chill Hatch. The No Chill Hatch is a single unit box made without any method of refrigeration. The front of The No Chill Hatch (i.e., the side facing the street) has a single hatch door; the back of The No Chill Hatch (i.e., the side facing the Sanctuary) has two cabinet doors. A triangle roof is placed above The No Chill Hatch as a cover.

The front hatch door pulls upwards to access the food inside of the unit; the hatch door is accessible to the community. The back-cabinet doors pull open to allow for the restocking of food; the cabinet doors are accessible only by the Sanctuary.

Vents are located on the top and side of the unit to reduce humidity and allow air flow. The side unit vent allows cool air to enter the unit, and the top unit vent accounts for the rising of heat and ensures that the heat that rises exits the unit. The unit does not have a shelf; the absence of a shelf allows food to be hung if necessary.

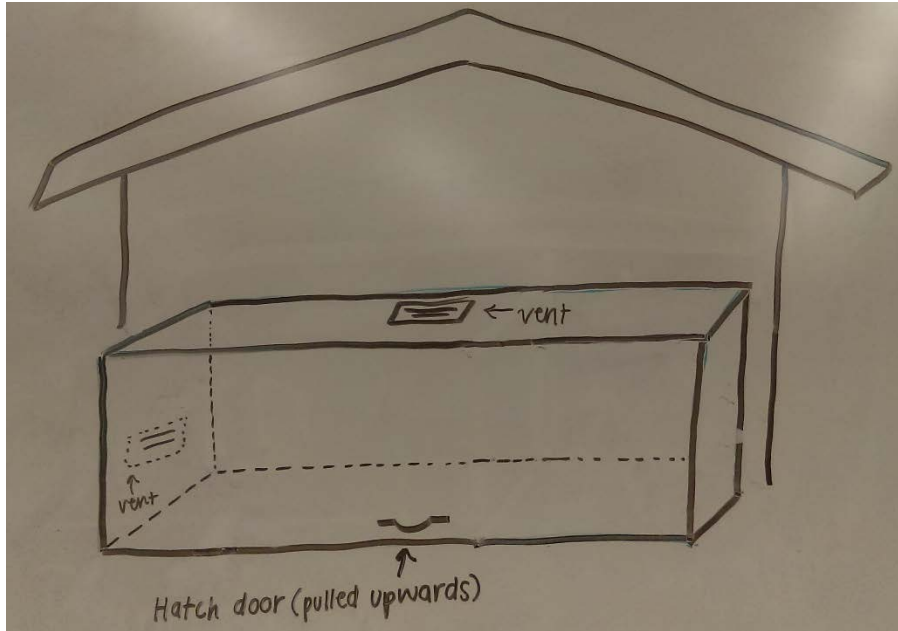

Figure 3-13 The No Chill Hatch is a single unit box that has a hatch door in the front, a triangle roof for cover and no method of refrigeration. A vent is located on the top and side of the unit for ventilation.

## 4 Decision Process

### 4.1 Introduction

Section four outlines how The A Team came to the final design of the abundant free food kiosk. A list of defined criteria for the project is described in this section and all twelve alternative solutions to the project are listed. The decision process was then explained with the main decision making method being the Delphi matrix. The final decision is included in the Decision Process subsection. Section four explains our final design decision and why it was chosen.

### 4.2 Criteria

The criteria listed below were outlined in Section two and are defined below in more detail.

- 1.) **Aesthetics:** The final design will be pleasing to the eye as well as fit in with the theme of The Sanctuary.
- 2.) **Cost:** The cost of the entire project will not exceed four hundred dollars with a maximum of seventy-five dollars contributed from each team member and one hundred dollars contributed from The Sanctuary.
- 3.) **Replicability:** The kiosk must be designed in such a way as to allow teenagers through adults to be able to rebuild the kiosk in under eighty-five hours.
- 4.) **Safety:** The kiosk must be safe enough to not be hazardous to the public with no to limited knowledge of how the kiosk works.

- 5.) **Accessibility (for public):** The kiosk must be easy for people of all ages to access without any instruction.
- 6.) **Critter proof:** The kiosk needs to be able to keep out insects, rodents and large mammals.
- 7.) **Durability:** The kiosk needs to be operable and self-supported for the next ten years.

### 4.3 Solutions

The A Team designed twelve different alternative solutions in section three for the abundant free food kiosk. The twelve solutions for the abundant free food kiosk are the following:

- The Cold Mailbox
- The Zeer Box
- The House Cabinet
- The Chill Slider
- The Zeer Slider
- The Pyramid
- The Kool Kabinet
- The Terra Cottage
- The Hot Shelf
- The Chill Hatch
- Pot O` Gold
- The No Chill Hatch

### 4.4 Decision Process

The A Team used the Delphi matrix table 4-1 method below to help guide a final design for the abundant free food kiosk. The criteria from section two are listed and each given a weight based on importance with ten being a very important aspect of the project and one being the least important aspect. The weighted criteria can be found in table 4-2 below. After the weights of each criterion were decided, the group graded each alternative solution according to the criteria. Each solution was graded with a number from zero to fifty per criteria. A score of fifty represented the best rank for each criterion and zero representing the worst rank for each criterion per each solution. The ranks were then multiplied by the weighted number assigned to each criterion. The sum of the products of weights of each criteria was then added together to get a total number. This number represented how compliant each alternative solution was with all of the criteria. The largest number represented the most optimal solution.

Table 4-1 Delphi Matrix of Alternative Solutions

Criteria	Solutions										
	weight	The Cold Mailbox		The Zeer Box		The House Cabinet		The Chill Slider		The Zeer Slider	
Aesthetics	6	25	150	25	150	35	210	25	150	25	150
Cost	3	40	120	35	105	45	135	40	120	35	105
Replicability	5	45	225	35	175	45	225	45	225	35	175
Safety	10	45	450	45	450	45	450	40	400	40	400
Accessibility (for public)	10	30	300	30	300	30	300	35	350	35	300
Critter proof	10	40	400	45	450	40	400	45	450	45	450
Durability	8	50	400	50	400	50	400	50	400	50	400
<b>Total</b>		2045		2030		2120		2095		1980	

Solutions										
The Pyramid	The Kool Kabinet	The Terra Cottage	The Hot Shelf	The Chill Hatch	Pot O` Gold	The No Chill Hatch				
35	25	35	35	25	35	35	35	35	35	35
210	150	210	210	150	210	210	210	210	210	210
45	40	35	45	40	35	45	35	45	45	135
135	120	105	135	120	105	135	105	135	135	135
45	45	35	45	45	35	45	35	45	45	225
225	225	175	225	225	175	225	175	225	225	225
40	50	50	50	25	25	25	25	25	25	250
400	500	500	500	250	250	250	250	250	250	250
35	50	50	50	25	25	25	25	25	25	250
350	500	500	500	250	250	250	250	250	250	250
40	45	45	40	40	40	40	40	40	40	400
400	450	450	400	400	400	400	400	400	400	400
50	50	50	50	50	50	50	50	50	50	400
400	400	400	400	400	400	400	400	400	400	400
2120	1845	2340	2370	1795	1790	1870				

Table 4-2 List of criteria and their weight

Criteria	
List	Weight
Aesthetics	6
Cost	3
Replicability	5
Safety	10
Accessibility (for public)	10
Critter proof	10
Durability	8

#### 4.5 Final decision

After the Delphi matrix was completed, the top three solutions were The Kool Kabinet, The Terra Cottage and The Chill Slider. The A Team has decided to go with a combination of the top two (The Kool Kabinet and The Terra Cottage) for the final design. The Terra Cottage will be combined with the chill box refrigeration aspect of The Kool Kabinet to make the final design. The new name of the final design is The Terra Cabinet.

## 5 Specification of solution

### 5.1 Introduction

Section five includes a detailed outline of building instructions, costs associated with the abundant free food kiosk and results of the project. A description of the final solution is outlined in this section along with instructions to build each aspect of the abundant free food kiosk. Some of the sub-sections include figures to help explain how each component is built. A cost analysis of the entire project is represented with tables and figures. The design cost is a quantitative representation of the total number of hours the A team has spent on the project. The cost of materials used in this project is outlined in a table and maintenance cost is outlined in another table. This section also includes instructions for implementation which explain how the owner and public use the abundant free food kiosk. The results and discussion section explains how the kiosk functions in the community and what problems came up while prototyping.

## 5.2 Solution description

The final design of the abundant free food kiosk was a combination of the alternative solutions The Terra Cottage and The Kool Kabinet. This model was renamed The Terra Cabinet. This design has been modified by the client after the design decision was made to have the roof slanted backwards.

### 5.2.1 The Frame

The frame of the food kiosk is made from several 2 by 4 inch pieces of wood (2x4's). There are four 2x4's attached to each corner of the upper cabinet. Two 2x4's will be attached to the short sides of the frame. These crossbars will be screwed onto the legs in a way that it would not block any of the cabinet doors if a bottom cabinet were to be added. This frame will provide stability for the kiosk.

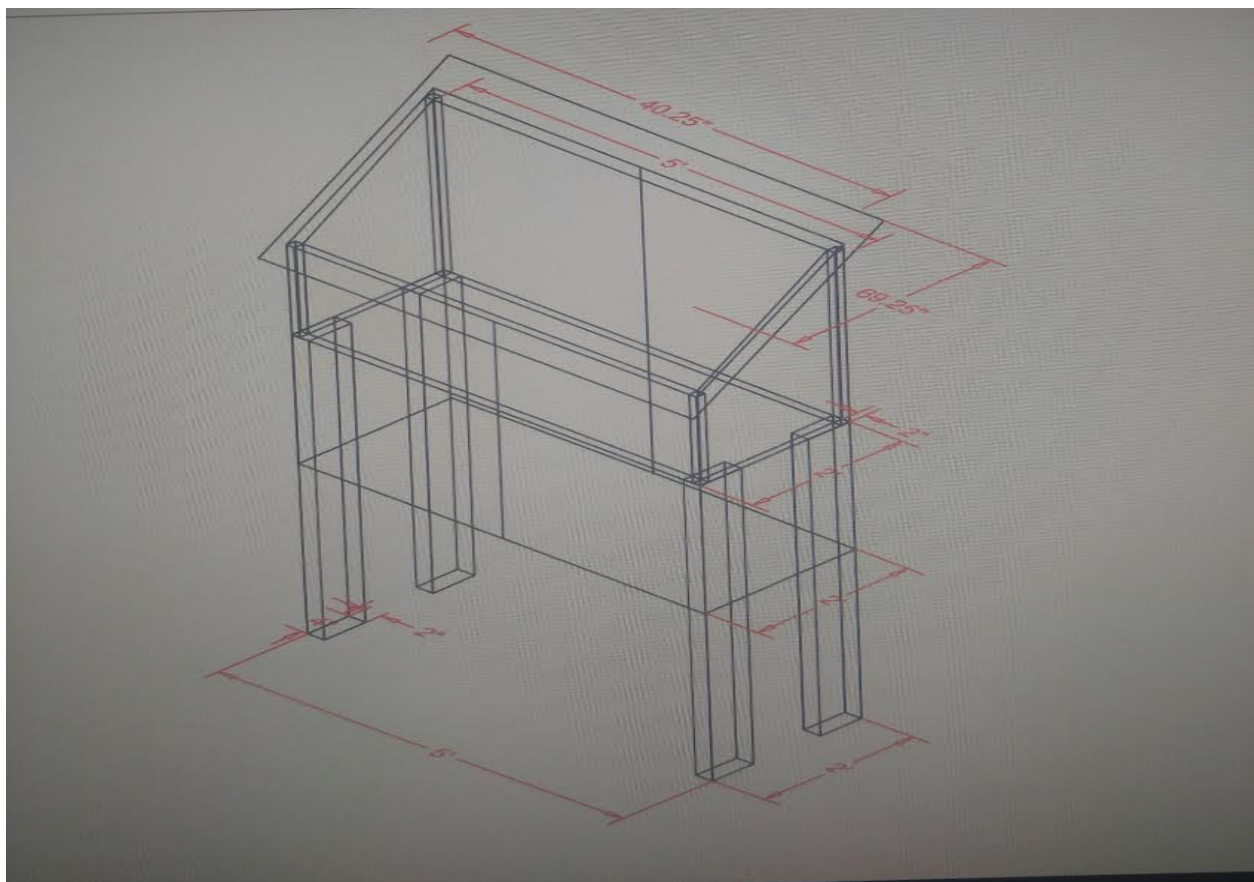

Figure 5-1 A view of the frame of kiosk

### 5.2.2 The Upper Cabinet

The upper cabinet will have food placed inside of it and is accessed by the public. This portion of the kiosk is completely insulated on every wall, except the doors. The bottom of the cabinet is 61 inches by 31.5 inches and 37 inches high on the front and 28.5 inches high on the back to account for the slanted roof. A trapezoidal shape piece of plywood was cut and a 2x2 31.5 inches long attached to the trapezoidal piece of plywood at the base. One side of the trapezoid has a 2x2 32 inches long attached to the front and one that is 28 inches long attached to the other side of

the trapezoid. The 2x2's are glued and screwed around the edges of the outer piece of plywood. Insulation will be placed in the gaps created and another piece of plywood with the same dimensions will be glued and screwed onto the 2x2's. The sides and bottom are screwed to each other as well as to the frame, and both have a layer of insulation between the pieces of plywood.

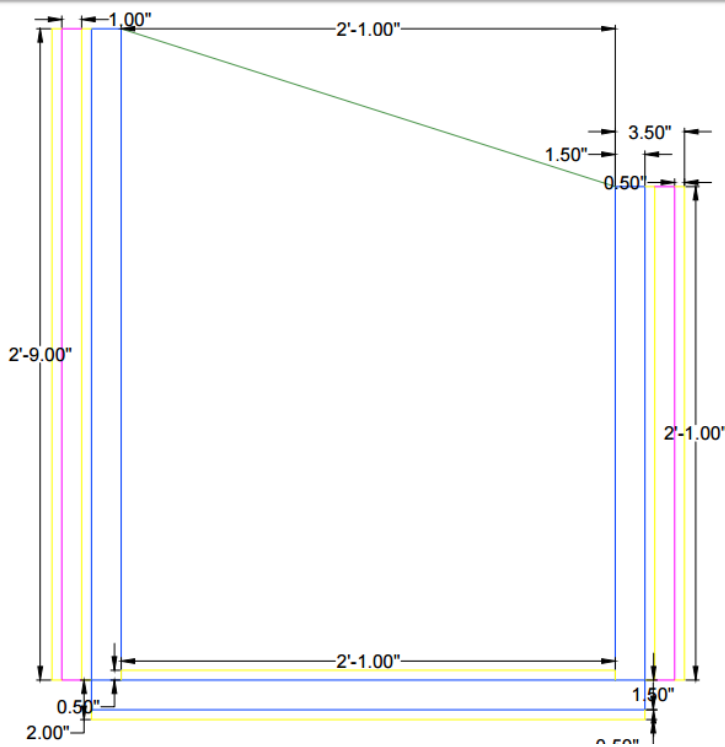

Figure 5-2 A side view of the upper cabinet that includes thickness, length and height dimensions

### 5.2.3 The Roof

The roof was placed on the top of the upper cabinet. A piece of plywood 68 inches by 40.5 inches was cut and two 2 by 2 inch pieces of wood (2x2's) 40.5 inches long was glued and screwed into the short ends of the plywood as well as 5 more spaced evenly inside. A layer of insulation was placed in the gap created by this frame and an additional piece of plywood was glued and screwed onto the 7 2x2's in the roof. The top piece of plywood is the same dimensions as the bottom piece of plywood with the corners cut out to allow space for the frame to fit. The roof is attached to the sides and back of the upper cabinet to seal the top.

### 5.2.4 The Doors

Doors are placed in the front and back of the upper cabinet and on the back of the lower cabinet. The doors on the back of the cabinet have window locks on the top and bottom, and the front doors have two handles and a small lock. There are magnets placed in the framing of the cabinet and washers on the inside of the doors to make sure the doors close properly in the front. The front doors are also painted with chalkboard paint on the top where the box contents can be shown. The door will not be insulated like the rest of the cabinet.

### 5.2.5 The Waterproof Coating

There is a waterproof coating for the kiosk of a white primer paint and a gloss coat. This coating protects the wood from rotting in the rain. It is also applied to all wood facing the outside of the kiosk and therefore may be exposed to rain.

## 5.3 Cost Analysis

### 5.3.1 Introduction

The costs of design, materials and maintenance related to the abundant free food kiosk are explained here in detail with charts, tables and explanations.

#### 5.3.1.1 Design Cost

Figure 5-2 below gives a visual representation of the number of hours that The A Team has put into the project. The hours spent working on the abundant free food kiosk include time spent in team meeting, meetings with the client, building time, researching the project, communication with the client and writing design documents. The total team time for this project is 290 hours and 10 minutes.



Figure 5-3 A pie chart representing The A Teams total time spent on the abundant free food kiosk

#### 5.3.1.2 Materials Cost

The materials cost was very low for the kiosk due to The Sanctuary being able to provide us with free wood, screws, wood glue, tools to use and a space to work and build. These costs are summarized in Table 5-1 below. Reproduction costs are not included in Table 5-1. Most materials and tools used were donated by the client with no cost to The A Team. The total price of the project came out to be \$22.00.

<b>Material</b>	<b>Cost (\$)</b>
2x4's	Donated
2x2's	Donated
Plywood	Donated
Wood glue	Donated
Screw driver	Donated
Screws	Donated
Waterproofing spray	Donated
Paint (colors)	Donated
Paint (chalkboard)	\$15.00
Cabinet handles	Donated
Insulation	Donated
Small paint brushes	\$7.00

Table 5-1 The list of materials and their respective costs needed to build the abundant free food kiosk

### 5.3.1.3 Maintenance Cost

The maintenance cost for the abundant free food kiosk is inexpensive. The kiosk will need to be cleaned twice a month with Lysol wipes. It will have an inexpensive replacement cost of parts each year. These costs are outlined in Table 5-2.

<b>Material</b>	<b>Time</b>	<b>Annual Cost</b>
Disinfectant wipes	5 minutes (monthly)	\$5.00
General parts for replacement	2 hours (annual)	\$10.00

Table 5-2 Materials needed to maintain the project, time it will take to use that material to maintain the project and the annual cost of the maintenance

### 5.3.2 Instructions for implementation and use of model

Before construction of the abundant free food kiosk, all materials should be gathered. An abundant free food kiosk best built on-site because is it hard to move due to its size and weight. An area 6.5 feet x 2 feet x 7 feet must be available and cleared for the kiosk. Once the kiosk is built, food can be put in the upper cabinet for public access, extra food can be stored in the lower cabinet and details about the food can be written on the front doors of the upper cabinet on the chalkboard paint. The public can then open the doors to access the food in the upper cabinet and the owners can access the cabinets via the back doors.

### 5.3.3 Results and discussion

The results of the free food kiosk showed that it is an effective way of handing out free food to the public without much hassle. Those who want to give it out to the public can do so by placing the food in the upper cabinet and writing the available food on the chalkboard. This will save a great amount of time instead of someone personally handing food out and one's possible confusion of where to get free food. The abundant free food kiosk is a convenient way for people in a community to attain free food.

While prototyping, The A Team came across a few issues.

- Community members said that they did not like how low you had to bend down to reach the food. It was unable to be fixed because if the kiosk was raised any higher, The Sanctuary would not be able to reach the back doors of the upper cabinet to put food into it.
- Community members suggested that it would be nice if the kiosk functioned like an ice cream freezer. They thought it would be nice if the kiosk had clear doors on the top and instead of reaching into a cabinet, they could reach down into it. If we did build a model like this, we would have had to redo our entire design. The A Team concluded that this would not be a plausible option because clear doors are not an efficient way for keeping the temperature low inside of the kiosk. If the community members did reach down into the kiosk to grab the food, a roof (which is a necessity in this climate) could not be built.
- The community members did, however, appreciate how the kiosk would be water and bug proof.

## Appendix A Brainstorming sessions

Below are photos of The A Team's brainstorming session on alternative solutions. This brainstorm was conducted in Sci D17 in the evening.

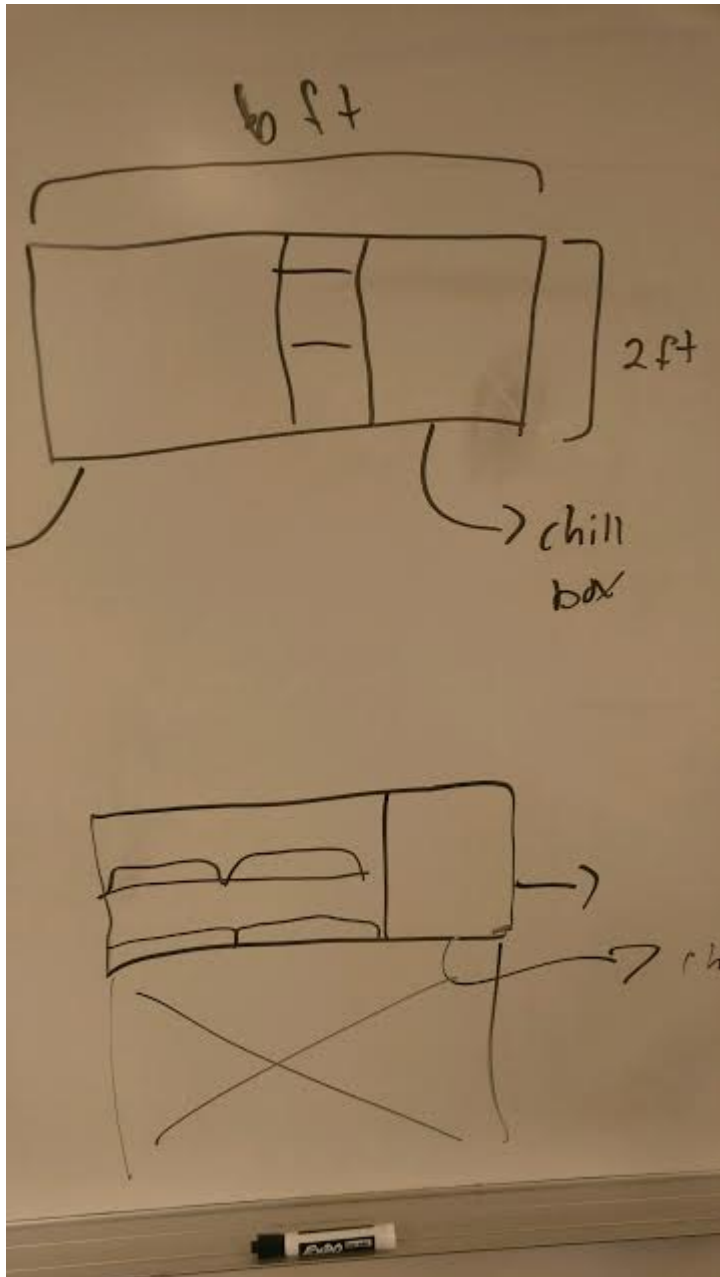

from life

the Math

↳ Sun

↳ Air

↳ Geometric Mean

lined

Base

4 legs w/ cross bars  
sitting on a box  
cemented to the ground

- on a track  
for  
maintenance
- aqua globe
- absorption

Refrigeration

zeer pot  
vapor compression  
solar mechanical  
Dry ice  
door-sealed & insulated

Shelving

square compartments  
different levels  
flying banana (hooks on ceiling)

Doors

Sliding  
mailbox (down)  
hatch (up)  
Spring  
window/clear  
chalkboard  
locks  
• combo  
• key  
back doors too

Roof

slanted  
metal  
flat  
triangular

lining

upcycled  
• plastic  
• tarps

## Alternative Solutions Brainstorm

2 mini fridges  
Sliding doors  
mailbox doors  
opening door (hatch)  
Spring door  
Slanted roof  
metal roof  
Actual cooler  
Zeer pot (cement)  
Square compartments  
Shelves / levels  
Flying bananas

4 legs w/ cross bars  
sitting on a box  
Cemented into the ground  
Window doors  
Clear doors  
Chalk board doors  
different placement of vents  
flat roof  
triangle roof  
Umbrella roof (cement)  
locker locks  
• combo  
• key

### fridge door

- sealed
  - insulated
  - big
- different kinds of base doors
- same as front doors
  - insulated

### lining

- upcycled
- plastic

### refrigeration thing on a door

- for maintenance
- on a track like a dresser drawer

aque glade

## Appendix B Prototyping Photos

Below are photos of the abundant free food kiosk's prototyping where The A Team had community members walk by the "kiosk" and grab some produce out of it.









## Appendix CReferences

- "Thermal Energy Storage." *Wikipedia*. Wikimedia Foundation, 6 Sept. 2016. Web. 24 Sept. 2016. <[https://en.wikipedia.org/wiki/Thermal\\_energy\\_storage#Solar\\_energy\\_storage](https://en.wikipedia.org/wiki/Thermal_energy_storage#Solar_energy_storage)>.
- By Design Has an Online Calculator for Sun Angles and from That You Can Figure the Overhang Calculations., Sustainable Sources. "Passive Solar Design." *Passive Solar Design*. Sustainable Sources, n.d. Web. 25 Sept. 2016. <<http://passivesolar.sustainablesources.com/>>.
- By Providing a Delightful Place to Live and Work, Passive Solar Buildings Can Contribute to Increased Satisfaction and User Productivity. In Addition, Passive Solar Design Does Not Generate Greenhouse Gases and Slows Fossil Fuel Depletion. "Passive Solar Heating." *WBDG*. National Institute of Building Sciences, 24 Aug. 2012. Web. 27 Sept. 2016. <<http://www.wbdg.org/resources/psheating.php>>.
- "Little Free Pantry." *Rare.com*. Rare, n.d. Web. 24 Sept. 2016. <<http://rare.us/story/free-food-and-supplies-are-always-at-this-outdoor-pantry-to-help-the-local-community/>>.
- "Read Me." *RSS*. The Little Free Pantry, 2016. Web. 24 Sept. 2016. <<http://www.littlefreepantry.org/news/>>.
- "Plans and Tips For Library Builders." *Little Free Library*. Little Free Library, 13 May 2016. Web. 26 Sept. 2016. <<https://littlefreelibrary.org/build/>>.
- Sisson, By Patrick. "The Little Free Pantry | Facebook." *The Little Free Pantry | Facebook*. Facebook, 9 Sept. 2016. Web. 27 Sept. 2016. <<https://www.facebook.com/littlefreepantry/>>.
- Gordon, Jay. "Ice Cream Cart." *Behance*. Adobe Systems Inc., 2 Jan. 2015. Web. 27 Sept. 2016. <<https://www.behance.net/gallery/22418061/ice-cream-cart>>.
- March, Eric. "A Woman Saw Hungry People Digging in Her Restaurant's Trash, so She Put a Fridge Outside." *Upworthy*. Cloud Tiger Media, 28 Mar. 2016. Web. 27 Sept. 2016. <<http://www.upworthy.com/a-woman-saw->

hungry-people-digging-in-her-restaurants-trash-so-she-put-a-fridge-outside>.

- News, BBC. "India Tackles Food Waste Problem - BBC News." *BBC News*. BBC News Service, 3 July 2014. Web. 27 Sept. 2016. <<http://www.bbc.com/news/business-28139586>>.
- OMICS. "Upcycling." OMICS International (2014): n. pag. 2014. Web. 25 Sept. 2016. (<http://research.omicsgroup.org/index.php/Upcycling>)
- Webster`s New Dictionary. (1984). In *Webster`s New Dictionary and Roget`s Thesaurus* (3rd ed). Nashville, TN. (p. 592)
- <http://www.gsa.gov/portal/content/111758>
- "What the Heck Is Upcycling." *Transition Town Payson*. N.p., 16 Feb. 2013. Web. 04 Dec. 2016. <<https://transitiontownpayson.net/2013/02/16/what-the-heck-is-upcycling/>>.
- "Galvanized Iron And Steel: Characteristics, Uses And Problems."Galvanized Iron And Steel: Characteristics, Uses And Problems. US General Service Administration, 13 July 2016. Web. 28 Sept. 2016.
- [http://www.galvanizeit.org/uploads/publications/Performance\\_of\\_Galvanized\\_Steel\\_Products.pdf](http://www.galvanizeit.org/uploads/publications/Performance_of_Galvanized_Steel_Products.pdf)
- "Specification for Zinc (Hot-Dip Galvanized) Coatings on Iron and Steel Products." (n.d.): n. pag. Galvanizeit.org. American Galvanizers Association. Web. 26 Sept. 2016.
- <http://www.gaa.com.au/uploads/Atmospheric%20Corrosion%20Resistance%20of%20HDG%20Coatings.pdf>
- "Galvanized Iron And Steel: Characteristics, Uses And Problems."Galvanized Iron And Steel: Characteristics, Uses And Problems. US General Service Administration, 13 July 2016. Web. 28 Sept. 2016.
- <http://www.kulturturizm.gov.tr/EN,98769/wood-as-a-building-material-its-benefits-and-disadvanta-.html>
- Ozen, Ramazan, Dr. "Wood as a Building Material; It's Benefits and Disadvantages." *Www.kulturturizm.gov.tr*. Ministry of Culture and Tourism, n.d. Web. 27 Sept. 2016.

- <http://www.gsa.gov/portal/content/111754>
- ["Aluminum: Characteristics, Uses And Problems." Aluminum: Characteristics, Uses And Problems. US General Service Administration, 04 Aug. 2016. Web. 28 Sept. 2016.](#)
- [https://www.fema.gov/media-library-data/20130726-1536-20490-4305/fema499\\_1\\_7.pdf](https://www.fema.gov/media-library-data/20130726-1536-20490-4305/fema499_1_7.pdf)
- ["Coastal Building Materials." Www.fema.gov. National Association of Home Builders Research Center, n.d. Web. 27 Sept. 2016.](#)
- <http://www.engineeringcivil.com/use-of-aluminium-in-building-construction.html>
- [By Prof. Madhuri K. Rathi, Mr.Ajinkya K. Patil. "Use of Aluminium In Building Construction." Use of Aluminium In Building Construction. Civil Engineering Portal, n.d. Web. 28 Sept. 2016.](#)
- <http://www.plexiglas.com/export/sites/plexiglas/.content/medias/downloads/sheet-docs/plexiglas-general-information-and-physical-properties.pdf>
- [Balzarini, D. "Cerenkov And Scintillation Properties Of Plexiglas Uvt And Uva." \(1960\): n. pag. Www.plexiglas.com. Altuglas International Arkema Group. Web. 27 Sept. 2016.](#)
- <http://energy.gov/energysaver/energy-efficient-window-treatments>
- ["Energy Efficient Window Treatments." Department of Energy. N.p., n.d. Web. 28 Sept. 2016.](#)
- [Dietetic Services. "State Regulations Pertaining to Preparation and Storage of Food." \(2011\): 3-4. Web. <http://www.hpm.umn.edu/nhregsplus/NH%20Regs%20by%20Topic/NH%20Regs%20Topic%20Pdfs/Dietary%20-%20Preparation\\_and%20Food%20Storage/category\\_dietary\\_services\\_preparation\\_and\\_food\\_storage\\_FINAL.pdf>.](#)
- ["Human Resource Management in Nonprofit Organizations." \(2011\): n. pag. California Department of Public Health, 30 Sept. 2014. Web. <https://www.cdph.ca.gov/pubsforms/Documents/fdbRIgde32.pdf>.](#)

- Holmes, Tamara E. "1-855-257-6195." Could Your Donated Food Get You Sued? Net Quote, n.d. Web. 29 Sept. 2016.  
<<http://www.netquote.com/home-insurance/food-donation>>.
- "Solids-Specific Heats." The Engineering Toolbox. N.p., n.d. Web.  
<[http://www.engineeringtoolbox.com/specific-heat-solids-d\\_154.html](http://www.engineeringtoolbox.com/specific-heat-solids-d_154.html)>.
- "Thermal Conductivity." The Engineering Toolbox. N.p., n.d. Web.  
<[http://www.engineeringtoolbox.com/thermal-conductivity-d\\_429.html](http://www.engineeringtoolbox.com/thermal-conductivity-d_429.html)>.
- "Insulation." Department of Energy. Office of Energy Efficiency & Renewable Energy, n.d. Web. 29 Sept. 2016.  
<<http://www.energy.gov/energysaver/insulation>>.
- USDA. "How Temperatures Affect Food." FSIS. N.p., n.d. Web.  
<[http://www.fsis.usda.gov/wps/portal/fsis/topics/food-safety-education/get-answers/food-safety-fact-sheets/safe-food-handling/how-temperatures-affect-food/ct\\_index!/ut/p/a1/jZHfT8IwEMf\\_mj2Wdg7J8G1ZYmDKJiFK2Qsp27VdsrVLW5z619vhEwaUu6e7-3xzv3CJKS4Ve28Ec41WrB3jcrYnazIL5ynJinn4SJb527p4SIMSb-49sPsDyKMb9VcsIf\\_pxsas3JlVuhK47JmTqFFcYyrAIabsAMZiyRWukWUc3CfirHLISgDnC2MOnaqSqbpTMBU6gE56HowzB0NWMQ4B68ZMUwrt29UDR94i8vzyUjofZlHm-kiyyNSTH8DF073A1y\\_jV9etPpw-tMuUYco9lsa4GDATI7Gp6VzvX0ISECGYZgIrUULk0p3Abkkkdo6TM9J3Hev9Os5WZDmpdvGNvkGeWjWLQ!!/#top](http://www.fsis.usda.gov/wps/portal/fsis/topics/food-safety-education/get-answers/food-safety-fact-sheets/safe-food-handling/how-temperatures-affect-food/ct_index!/ut/p/a1/jZHfT8IwEMf_mj2Wdg7J8G1ZYmDKJiFK2Qsp27VdsrVLW5z619vhEwaUu6e7-3xzv3CJKS4Ve28Ec41WrB3jcrYnazIL5ynJinn4SJb527p4SIMSb-49sPsDyKMb9VcsIf_pxsas3JlVuhK47JmTqFFcYyrAIabsAMZiyRWukWUc3CfirHLISgDnC2MOnaqSqbpTMBU6gE56HowzB0NWMQ4B68ZMUwrt29UDR94i8vzyUjofZlHm-kiyyNSTH8DF073A1y_jV9etPpw-tMuUYco9lsa4GDATI7Gp6VzvX0ISECGYZgIrUULk0p3Abkkkdo6TM9J3Hev9Os5WZDmpdvGNvkGeWjWLQ!!/#top)>.
- NOAA (National Oceanic and Atmospheric. "Arcata, Ca Weather." Area Vibes. N.p., n.d. Web. <<http://www.areavibes.com/arcata-ca/weather/>>.
- Andreas, Afshin. "NREL: MIDC/Humboldt State University (40.88 N, 124.08 W, 36 M, GMT-8)." NREL: MIDC/Humboldt State University (40.88 N, 124.08 W, 36 M, GMT-8). NREL, n.d. Web. 29 Sept. 2016.  
<<http://www.nrel.gov/midc/hsu/>>.
- Baker, Rex O.; Bodman, Gerald R.; and Timm, Robert M., "Rodent-Proof Construction and Exclusion Methods" (1994). The Handbook: Prevention and Control of Wildlife Damage. Paper 27.
- Emergency Outdoors. "Protecting Your Food Storage From Pests." Emergency Outdoors Blog. N.p., n.d. Web. 29 Sept. 2016.

<<http://blog.emergencyoutdoors.com/protecting-your-food-storage-from-pests/>>.

- Klein, S. A., and Reindl, D. T. (2005). "Solar Refrigeration." American Society of Heating, Refrigerating and Air-Conditioning Engineers, 47(9), S26-30.
- R, P. S. D. (2016). "Experimental Comparative Analysis of Clay Pot Refrigeration Using Two Different Designs of Pots." International Journal of Latest Research in Engineering and Technology (IJLRET), 2(2), 30-35
- REI. "Food Handling and Storage for Campers." REI. N.p., n.d. Web. 29 Sept. 2016. <<https://www.rei.com/learn/expert-advice/food-handling-storage.html>>.