

Electric Bicycle and Agricultural Trailer

Final Project Report

Group member names

Linus Garrett¹

Jack Baker²

Jon Higginbotham³

2010/3

Project Sponsor: OSU Organic Growers Club

ME 418/419 Project Number: 5

Faculty Advisor: Dr. Bay

Sponsor Mentor: Ronjon Datta

¹ Lead editor #1, Linus Garrett

² Lead editor #2, Jack Baker

³ Lead editor #3, Jon Higginbotham

DISCLAIMER

This report was prepared by students as part of a college course requirement. While considerable effort has been put into the project, it is not the work of a licensed engineer and has not undergone the extensive verification that is common in the profession. The information, data, conclusions, and content of this report should not be relied on or utilized without thorough, independent testing and verification. University faculty members may have been associated with this project as advisors, sponsors, or course instructors, but as such they are not responsible for the accuracy of results or conclusions.

TABLE OF CONTENTS

ACKNOWLEDGEMENTS	4
1.1. Background	5
1.2. Requirements	5
1.2.1. Project Requirements	5
1.2.2. Customer Requirements (CRs)	6
1.2.3. Engineering Requirements (ERs)	7
1.2.4. Testing Procedures	11
1.2.5. House of Quality (HoQ) SEE NEXT PAGE	12
2. EXISTING DESIGNS, DEVICES, AND METHODS	13
2.1. General Discussion	13
2.2. Descriptions	13
2.2.1. Bikes at Work Model 64A Bike Trailer	14
3. DESIGNS CONSIDERED	18
3.1. Electrical Assist	18
3.1.1. Hub Motor:	18
3.2. Trailer:	19
3.2.1. Brakes:	19
3.2.4. Welded vs. Bolted vs. Bamboo Construction:	19
4. DESIGN SELECTED	21
4.1. Rationale for Design Selection	21
4.2. Design Description	23
4.2 Design Description	23
4.2.1. Bicycle:	24
4.2.1.1. Brakes:	24
4.2.1.2. Hitch System:	24
4.2.2. Electrical Assist:	24
4.2.2.1. Motor:	25
4.2.2.2. Chain-wheel System:	25
4.2.2.3. Throttle:	25
4.2.2.4. Controller:	25
4.2.2.5. Batteries:	25
4.2.3. Trailer:	26
4.2.3.1. Brakes:	26
4.2.3.2. Materials:	26
5. IMPLEMENTATION	27
6. TESTING	29
7. PROJECT SUMMARY	30
8. BIBLIOGRAPHY	32
9. APPENDIX A: ENGINEERING CALCULATIONS	33

ACKNOWLEDGEMENTS

Special thanks to: Dr. Brian Bay of OSU, Ronjon of the OGC, Jonas and Vernon from the Bike Co-op, Arbor Creek Farms, and Allen from White's Electronics.

PROJECT DESCRIPTION

1.1. Background

The purpose of this project was to design and manufacture a means of transporting agricultural products from the Organic Growers Club (OGC) farm to the market where these products are sold. The OGC is an organization operated by OSU faculty involved with the Student Sustainability Initiative and thus is not only a grower of organic products, but an organization used to instruct students about sustainable agricultural practices. Currently the OGC uses an internal combustion vehicle (pick up truck or van) to complete this task and specifically wishes to further their sustainable practices by replacing their vehicle with an electrically assisted bicycle and trailer. Replacing the current internal combustion engine truck with this system would give the OGC educational value in that it could be used to instruct students on the importance of not only how products are produced, but also how they are transported to where they are sold.

1.2. Requirements

This project required the use of both engineering and sustainability concepts. Engineering principles were needed in the design or choice of components used, interfaces between components, and analysis of system effectiveness. In conjunction with sound engineering techniques, our sponsor specifically desired a product that uses sustainable practices, such as recycled or re-used components, to meet the initial requirements as outlined by the sponsor.

1.2.1. Project Requirements

Project Sponsor: Student Sustainability Initiative

ME 418/419

Project Number: 5

Faculty Advisor: Dr. Bay

Sponsor Mentor: Ronjon Datta

We will need to modify a used mountain bicycle in order to support an electrically powered motor. The motor will be attached to the hub of the rear wheel. The electric assist system has a battery, which needs to be mounted either on a rack or to the top tube. The battery must be chargeable by a standard outlet.

The final component of the system is the throttle - it must be mounted on the handlebars in a position which is easy to use amongst the brakes and gear shifters. In order to optimize the electric assist for the purposes of this project, we will need to find the appropriate specifications for:

- Hub motor – direct drive or geared; appropriate power for our cargo capacity needs
- Battery – voltage, capacity, and ion type
- Throttle type – thumb or grip twist

For bicycle trailer construction, we will need to design an appropriate frame for carrying 300-500 lbs of cargo. The trailer frame will need to be welded appropriately for the system. We will also need a stable hitch to attach the trailer to the bike.

At least one student group member should be a competent welder.

The entire system (hub motor wheel, battery pack, and throttle) must be transferable between mountain bikes of similar size. Mountain bikes using the system need disc brakes. The hub motor wheel must fit

into standard mountain bike drop-outs, and there must be a place for throttle and battery to be mounted. The battery and motor must provide appropriate power for pulling a range of 200 – 500 lbs of weight (includes cargo, bike/trailer/electric assist system, and rider). The trailer specifications will follow these guidelines:

- cargo area: 96" x 19.25" (244 cm x 49 cm)
- overall dimensions: 121" x 28.75" (307 cm x 73 cm)
- width between fenders: 23.25" (59 cm)
- ground clearance: 7.5" (19 cm)
- maximum length of cargo: 15' (4.57 m)
- weight: 43 lbs (20 kg) (approx.)

In addition, all efforts to use scrap or donated metal for trailer frame and parts are necessary. Bicycle will be from a used-bike pool.

Cost must not exceed \$1000

1.2.2. Customer Requirements (CRs)

The customer requirements (see below) for this project fell into four main categories: General, Trailer, Bike, and Electric Assist. Within the General category are overarching requirements that the other three categories also need to follow such as safe, strong, and made of used and donated parts. “Safe” and “strong” are obvious and near universal requirements, while “made of used and donated parts” was specific to the OSU Organic Growers Club. The waste and emissions of existing parts have already been absorbed by the environment and thus we have already dealt with their effects. Being environmentally conscious, the OSU Organic Growers Club did not want us to create significant amounts of new waste and emissions in the completion of this senior project.

General

- Safe
- Road legal
- Strong/Durable
- Makes use of donated or recycled components
- Within indicated budget

Safety and legality were the two foremost customer requirements due to SSI’s official status as part of Oregon State University. Therefore Oregon law was observed in relation to safety and design of this product.

The system was to use recycled and used parts in order to practice sustainable ideals in accordance with the philosophy of the Student Sustainability Initiative.

Trailer

With regards to the trailer, the OSU Organic Growers Club desired basic characteristics such as stability and road legality as well as some unique requirements such as dimensions designed around Rubbermaid tubs. The OGC uses these Rubbermaid tubs to transport their produce from the field to the vehicle. By designing the trailer around these tubs we incorporated a successful part of the existing process.

- 250 lbf cargo capacity
- Stable cargo loading
- Stable trailer hitch

- Accommodates Rubbermaid tubs (18 gal,14 gal,10 gal)

Ronjon Datta specified that the cargo trailer should be able to carry a load of 250 lbf. This cargo capacity will allow the OGC to transport produce in large enough loads in order to minimize back and forth trips. Cargo and trailer must be attached to the bicycle in a secure and stable manner. This requirement is needed in order to insure the bicycle rider's safety while in transit on roadways between destinations.

Bike

In addition to the general requirements, the bicycle needed to make use of disc brakes. Hauling a trailer introduced extra mass that must be brought to a stop, thus standard V-brakes would not be sufficient for this application.

- Uses mountain bicycle frame
- Uses disc brakes

A mountain bicycle frame was needed for the system to provide a robust platform. Although the bicycle was an essential component of this system, the technology pertaining to bicycles was already a mature one and therefore a bicycle was donated rather than designed.

Electric Assist

The reason for having an electrically assisted drive system was to make hauling a heavy load of produce easier on the bicycle rider. Due to this, the most important CR for the electric assist kit was to provide appropriate pulling power. Other customer requirements for the electric assist kit were meant to keep it standardized and universal.

- Rear wheel drive electric assist
- Battery chargeable by standard outlet
- Provides appropriate power for hauling loaded trailer
- Battery mounted on rack or top tube of bicycle frame
- Electric assist easily transferable to similar mountain bicycle designs

The electric assist system was to be mounted and contained in such a way that it provided stable and safe power for the bicycle operator. Aspects of interfacing the electric assist included a rear wheel drive motor that allowed for maximum traction, battery stability by mounting at standard bicycle frame mounting points, and appropriate motor output for the trailer with a 250 lbf cargo load in addition to the bicycle and its rider.

The motor battery was to be chargeable by a standard outlet such that it could be easily recharged and reused. This lengthened the useable lifespan of the product while using current infrastructure.

Lastly, the electric assist system was to be transferable to mountain bicycles of similar size and design to facilitate component repair or replacement as needed.

1.2.3. Engineering Requirements (ERs)

Engineering Requirement Discussion

General Requirements

1. ≥ 1 sq. ft. (930 cm²) of reflective material visible to rear [1.5 +/- 0.5 sq. ft.; 0.14 +/- 0.05 m²]

The goal here is safety, specifically visibility to auto traffic. Reflective material on the back of the bike will help make it more visible during the day and especially during the night. We felt that 1.5 +/- 0.5 sq. ft. of reflectors and reflective tape combined would be adequate and give us enough room to adjust as necessary.

2. At least 1 safety flag 6 ft. (1.83 m) above ground [7 +/- 1 ft; 2.1 +/- 0.3 m]

This ER is specifically for going over the bridge where cars have a limited line of sight distance. A tall safety flag will alert drivers that something is in the road so they will not be surprised coming over the crest of the bridge. We felt that 7 +/- 1 ft is tall enough that drivers will see it while still giving us room for adjustment.

3. At least 1 headlight that projects 50 ft (15.2 m) at night [60 +/- 10 ft; 18.3 +/- 3 m]

The harvesting work sessions usually run until sunset so this bike will likely travel at dusk or in the dark. A light that allows the rider to see 60 feet ahead will help him or her avoid obstacles and also allow drivers to see the rider. A tolerance of +/- 10 ft gives us room to select a product that fits in our budget.

4. Trailer frame factor of safety greater than 1.5 (from analysis) [2 +NA/-0.5]

Figuring out a way to measure “strong and durable” was a challenge. If we had the budget we could buy a fatigue cycle testing machine. Since we don’t, we are specifying that the trailer should not have components with a factor of safety less than 1.5.

5. More than 50% of the parts are donated/used parts [60 +40/- 10 %]

Using used and donated parts is important to our sponsor, so we decided that more than 50% of the parts should be used or donated. Striving for 60 +40/- 10 % gives us room for design considerations.

6. Includes 1 users manual and 1 laminated information card [(-)]

Our sponsor wanted a quick start information card attached to the bike and a user’s manual. There is no target here as they are either present or not present.

7. Is within the budget

Our sponsor has finite resources, therefore budget constraints are paramount. This engineering requirement either meets or does not meet the requirement.

Trailer Requirements

8. Trailer shall support load of 250 lbs (113 kg) [275 +/- 25 lb; 125 +/- 11.3 kg]

Here is the main point of the project: a bicycle trailer that can handle a large load of produce or other agricultural items. We want to slightly over build the trailer (hence the 275 lbs target), but we intend the static loading test to stop at 300 lbs.

9. At least Eight Rubbermaid tubs shall fit [8 +NA/-0 tubs]

The OSU Organic Growers Club transports their produce from the field to market using Rubbermaid tubs of various volumes. Although the volumes vary they all have the same footprint. We plan on a 4x2 configuration, with the possibility of a 3x3 if the top row is light enough. The 8 +NA/-0 tubs allows room for different configurations.

10. Includes "Slow Moving Vehicle" banner [(-)]

To be road legal the trailer will need a "Slow Moving Vehicle" banner on the back that is visible to motorists. There is no target as this is either present or not present.

11. Point force of 200 N at highest point on loaded trailer required to lift one side off ground. [50.6 +NA/- 5.6 lb; 225 +NA/- 25 N]

A target force of 225 N with a tolerance of +NA/- 25 N without wheel elevation was chosen to provide a large magnitude force that may be experience in trailer operation as well as a relatively large tolerance to account for a shift in center of mass.

Bike Requirements

12. Is a used mountain bicycle [(-)]

This requirement is the result of sponsor's desires. There is no target here as it is either present or not present.

13. Has disc brakes [(-)]

This requirement is the result of sponsor's desires. There is no target here as they are either present or not present.

14. Tire compound rating of less than 70a [65a +5a/-10a]

The tires shall have a compound rating of 65a +5a/-10a. A value of 65a was chosen by comparing the different compounds of mountain bicycles. A higher value indicates less traction but longer lifespan and using this information we chose our target to accommodate high traction as well as long lifespan to minimize tire replacement.

15. Less than 8 bolts securing each part [7 bolts +1/-6 bolts]

Each part shall have less than eight fasteners connecting it to the frame or trailer. A target of 7 bolts+1/-6 allows for a secure assembly while minimizing maintenance time.

Electric Assist Requirements

16. System powers rear wheel [(-)]

Power assist shall transfer power via rear wheel of bicycle. There is no target here as the capability is either present or not present.

17. Battery mounted in acceptable location [(-)]

Battery shall be mounted in one of the acceptable locations (rack, top tube, or trailer). There is no target here because the battery is either mounted in an acceptable location or it is not. .

18. Battery recharges on 120 V-60 Hz AC [(-)]

Electric assist battery shall be chargeable via US standard AC outlet of 120 V-60 Hz. There is no target here as the capability is either present or not present.

19. Uses standard commercially available throttle mechanism

There is no target here as the capability is either present or not present.

20. Transferring the system shall require no more than 5 tools [4 +1/-3 tools]

All the parts should be easy to remove if the sponsor wishes to replace or upgrade a part in the future. We feel that using 5 or fewer tools to remove each part satisfies this requirement and the tolerance allows us to use fewer tools for simpler parts

21. The system shall require no more than 20 fasteners [15 +5/-14 fasteners]

A total of 20 fasteners was chosen for the electrical assist since it must be easily transferred. Fasteners will include Velcro straps, bolts, screws and any other fastening device. The target of 15 +5/-14 allows us to exceed the customer's expectations and gives us room for design considerations.

22. The fully loaded bike and trailer shall be able to reach 15 mph on level ground [15 +5/-0 mph; 6.7 +2.24/-0 m/s]

Fifteen mph was chosen for the maximum velocity since that is what the sponsor requested. The tolerance gives us room for future design considerations.

23. The fully loaded bike and trailer shall be able to reach 10 mph on a 4 degree incline. [10 +10/-0 mph; 4.47 +4.47/-0 m/s]

Ten mph was chosen for a 4 degree incline because the sponsor needs it to travel 10mph on the Harrison Bridge in Corvallis. The 4 degree incline was determined from measuring the incline of the bridge. The tolerance gives us room for future design considerations.

24. The system shall score an average of 4 +/-0 out of 5 points on Smoothness Survey. [4 +/-0]

The customer requires that power must turn on smoothly which is not easily measurable. Therefore a survey of potential operators will be used to quantify this property. An average survey score of 4 +/-0 out of 5 will indicate the "power smoothness."

1.2.4. Testing Procedures

General Testing Procedures

1. Measure overall reflective material dimensions and calculate areas
2. Count number of safety flags and measure height to bottom of flag
3. Count number of headlights. To test the distance the headlight projects, in a long hallway with the lights turned off place a 1 sq. ft. matte black object 60 ft away from the headlight which will be mounted on the bike and determine if an independent observer can discern the object.
4. Load trailer to 375 lbs (FS of 1.5), subject to service experienced in normal route from OGC farm to campus, and ensure no decrease from previous functionality.
5. Calculate percentage of used parts using BOM by the relationship:
$$\%Donated = \frac{\sum N_{donated}}{\sum N_{total}}$$
6. Check for presence
7. Calculate total expenses with final BOM and subtract from total budget.

Trailer Testing Procedures

8. Load trailer evenly with eight Rubbermaid tubs filled with 37.5 lbs each of water. To test an extreme condition, pull trailer off a standard curb and ensure no decrease from previous functionality.
9. Load trailer with empty tubs and count. To test an extreme condition, pull trailer off a standard curb and ensure no tubs fall off or move more than 1 inch in any direction.
10. Check for presence.
11. Attach 2"x4" piece of lumber with I-bolt securely to fully loaded trailer sidewall with bolts. Attach fish scale to I-bolt and apply lateral force of 50.6 lb perpendicular to trailer floor pan. Check if wheel leaves contact with ground.

Bike Testing Procedures

12. Check for presence
13. Check for presence and functionality. To ensure performance, product shall have no more than 1.5 times the emergency braking distance (near full lock-up) from 15 mph of a normal bicycle with cantilever brakes.
14. Check and record tire rating on sidewall of tire.

15. Count number of fasteners required to attach all parts on bill of materials.

16. Check for presence

Electric Assist Testing Procedures

17. Check for presence (in one of the three acceptable locations), functionality (powers system), and security (each battery does not move more than 1/4 inch in any direction under normal operations).

18. Check for presence and ease of use (accessibility of plug).

19. Check for presence and functionality.

20. Count number of different fasteners that require different tools to remove on electric assist system.

21. Count number of fasteners required for system on electric assist system.

22. Find a stretch of level, asphalted ground approximately two hundred meters long. Load trailer to 250 lb target with water as ballast, allow 60 meters to accelerate, and measure time it takes to travel from a designated starting point to designated ending point. Measure the distance between these points and calculate velocity.

23. Find a stretch of asphalted ground with a 4 degree incline approximately two hundred meters long. We determined the 4 degree incline by measuring the maximum slope of the Harrison Street Bridge. Confirm incline with sextant measurements. Load trailer to 250 lb target with water as ballast, allow 60 meters to accelerate, and measure time it takes to travel from a designated starting point to designated ending point. Measure the distance between these points and calculate velocity.

24. Find population of five regular bike user's (people who use a bike >2 days/week) and survey their opinions pertaining to the smoothness of throttle to power response based on a scale of 0 to 5 with the datum being a normal bicycle.

1.2.5. House of Quality (HoQ) SEE NEXT PAGE

2. EXISTING DESIGNS, DEVICES, AND METHODS

2.1.General Discussion

The current state-of-the-art system for hauling cargo in a sustainable manner was electrically powered utility vehicles. These can vehicles range from small vehicles as seen used by Facility Services, to full-size electric trucks. The limiting factor with these state-of-the-art systems was the cost associated with purchasing these electric vehicles.

A discussion of the state-of-the-art of the individual components follows. Of the three major components of this project (trailer, bike, and electric assist kit), the OSU Organic Growers Club provided the bicycle. As such, it did not make sense to investigate existing bicycle designs because the bicycle had already been decided. However, the braking system on the bicycle had not been decided and did warrant background research along with the trailer and electric assist kit.

When research was conducted cargo bicycle trailers were a mature technology. They were used for many different purposes ranged from personal to commercial. A survey of the major manufacturers shows that most designs were similar and only differ in small features. The cargo carrying capacity of the leading manufacturers was sufficient for our purposes, however the cost was prohibitive.

Hydraulic disc brakes for bicycles were a relatively new technology. First introduced more than a decade ago, they have advanced significantly in terms of reliability and ease of operation. Modern hydraulic disc brakes were a necessity for this project and the systems designed for downhill mountain bike racing met our needs but not our budget.

Bicycle electric assist kits were available to meet a large variety of needs from light commuter to heavy-duty hauler. The controllers that operated the kits ranged from simple to sophisticated. Many of the stronger kits met our torque requirements, but few were within our price range.

2.2.Descriptions

Other than electric utility vehicles, there were not many examples of an entire system that performs the same function as our proposed system, but rather independent components that could be interfaced to result in a working system. These components consisted primarily of electric assist kits, bicycle trailers, and bicycle brakes.

Trailers

- Bikes at Work Model 64A
- Tony's Trailers Heavy Duty Hybrid
- Carry Freedom Bamboo

Hydraulic Disc Brakes

- Avid Code
- Hayes Stroker Ace

Electric Assist Kits

- BionX PL-250 HT
- Electric Rider Phoenix Brute

2.2.1. Bikes at Work Model 64A Bike Trailer

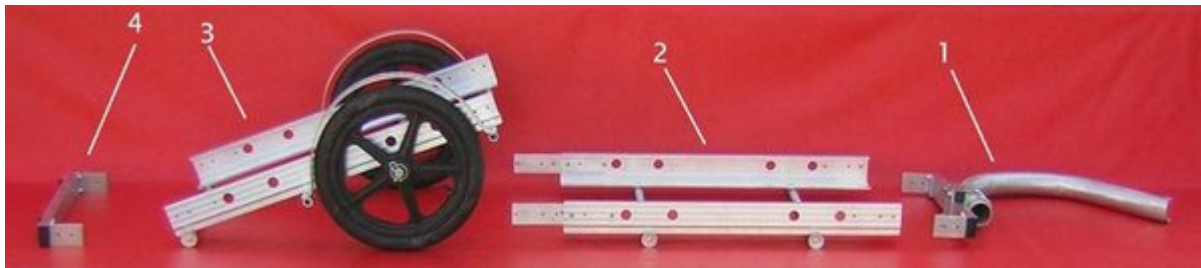

<http://www.bikesatwork.com/bike-trailers/features.html>

Figure 1: Bikes at Work trailer

Bikes at Work was one of the industry leaders in bicycle trailer construction. They used an extruded aluminum modular frame that allowed for adjustments in length. As can be seen in the Figure 1, the trailer could be completed using only parts 4, 3, and 1 or part 2 could be added to increase the length of the cargo bed. With its 300 lb carrying capacity, the Bikes at Work trailer would meet our basic needs but is beyond our budget. This model retails for \$460, which was nearly half our original budget.

2.2.2. Tony's Trailers Heavy Duty Hybrid Cargo Trailer



<http://www.tonystrailers.com/cargo/>

Figure 2: Tony's Trailers cargo trailer

Tony's Trailers was the other significant leader in manufacturing bicycle cargo trailers. Figure 2 shows their Heavy Duty Hybrid trailer which had a load rating of 500 lbs. Unlike the modular aluminum frame Bikes at Work trailer, this Tony's Trailer used more traditional welded tubular elements. Useful features on this trailer included a fold-down tailgate and side posts on which advertising banners could be mounted. The two-wheeled design could have proved to be limiting for heavy loads as weight distribution becomes more significant. For example, as Dr. Richard E. Klein found in a stable single track trailer project "...the front tire of the lead bike might have negative loading and thus become airborne" (Klein 49). Given that we can not control the loading process, more than two wheels may be necessary for stability. This trailer would have met our needs except, like the previous trailer, was too expensive at \$1200.

2.2.3. Carry Freedom Bamboo Bicycle Trailer

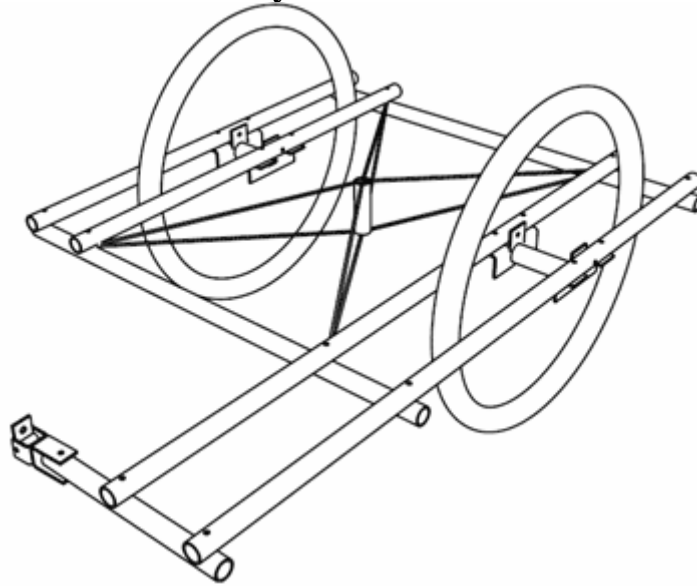

<http://www.carryfreedom.com/bamboo.html>

Figure 3: Schematic of Carry Freedom bamboo trailer

The Carry Freedom Bamboo Bicycle Trailer was a do-it-yourself open-source design meaning that the company did not sell complete trailers but does give out the designs for free to individuals. The only expenses would be the raw materials and time invested, so it was within our price range. People had reported hauling upwards of 300 lbs, so if properly constructed it would have met our load capacity needs. This design was not ideal for our purposes because of potential problems sourcing the bamboo.

2.2.4. Avid Code Hydraulic Disc Brakes



<http://www.sram.com/en/avid/hydraulicdiscbrakes/code.php#>

Figure 4: Rotor and Caliper of Avid Code Brakes

Avid is one of the top manufacturers of hydraulic disc brakes and this is their strongest brake available. The Code brake system is intended for downhill mountain bike racers. Downhill racers often reach speeds of 35 mph on tight trails, so braking is very important. This particular model has a four piston caliper. The Avid

Code would meet our needs for a strong brake except for its price: \$460 for a set, the same price as the Bikes at Work trailer.

2.2.5. Hayes Stroker Ace Hydraulic Disc Brakes



http://www.hayesdiscbrake.com/product_hyd_strokerAce.shtml

Figure 5: Rotor and Caliper of Hayes Stroker Ace Brakes

Similar to the Avid Code hydraulic disc brake, the Hayes Stroker Ace hydraulic disc brake is designed for downhill mountain bike racing. This design also has a four piston caliper to apply large forces on the rotor. However, the \$500 price tag of this system makes it inappropriate for our use.

2.2.6. Electric Rider Phoenix Brute Electric Assist Kit

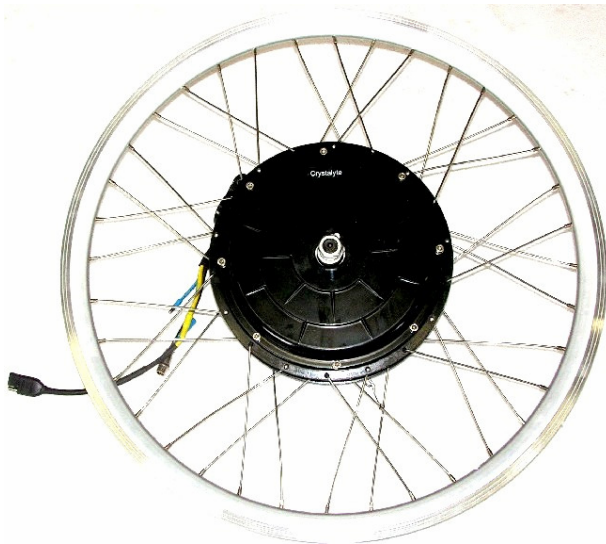

<http://www.electricrider.com/crystalite/index.htm>

Figure 6: Electric Rider Phoenix Brute Hub Motor

The Phoenix Brute electric assist kit by Electric Rider is one of the most powerful kits available. The motor can output a sustained torque of 12 Nm. Based on our initial calculations, this is enough to accelerate a stationary 50 lb trailer with a 250 lb load to 5 miles per hour in the space of a 30 foot long intersection. As with the BionX system, price is an issue as the complete kit retails for \$1300.

2.2.7. BionX PL-250 HT Electric Assist Kit



<http://www.bionx.ca/products/technology.php>

Figure 7: BionX Hub Motor

BionX manufactures the most sophisticated bicycle electric assist kits currently on the market. Their advanced controller and use of load cells in the hub motor allows the kit to provide just the right amount of assist based on the rider's pedal forces. Although they are not the most powerful kits on the market, they do output 9N-m of sustained torque. The Bionx PL250 electric assist kit provides a compact unit that is easily transferred to other bikes and is easily operated by thumb throttle. However, the characteristic drawback of this product is its price of \$1200. (Bionx, 2009)

3. DESIGNS CONSIDERED

In this section the designs considered are discussed. These were broken into two topics, the electrical assist and the trailer.

3.1. Electrical Assist

For the electrical assist there were three main designs considered: a hub motor, an integrated chain-driven system and a separate chain-driven system.

3.1.1. Hub Motor:

The hub motor design consisted of purchasing an existing hub motor and installing it to the rear wheel of the bicycle. The advantages of this design were that the motor was extremely compact, it has very few moving parts and that it was disc brake compatible. Because the motor was able to sit in the hub of the rear wheel it did not consume much space that would interfere with the rider which made it much safer than other designs. Also, since the motor was attached directly to the wheel there were no extra chains to transfer the power from the motor to the wheel. Lastly, this design allowed for the use of disc brakes because of its small profile.

The disadvantages of using this system were that it did not provide the necessary power, it would be difficult to gear and the kits were very expensive. Since the motor was directly attached to the wheel it would have been extremely difficult to gear. Finally, the kits cost about \$1000 to \$4000 which was outside our budget.

3.1.2. Integrated Chain-driven:

The integrated chain-driven option was where a motor would be placed in-line with the pedals. This motor would drive the chain which would drive the rear wheel. The advantages of this system were that it had gearing options and was customizable. Since the motor was attached to the bike chain it would make use of the gears already in place. Customization of this setup would be simple. For example, if more power was necessary, the motor could have been replaced by a higher power motor without having to do extensive redesign or spending too much.

The main disadvantage of this system was that there was a potential lack of freewheeling if no specialized freewheeling chain wheel mechanism was used. The term freewheeling refers to when the electrical assist is turned on and the pedals do not move with the motor. This design required the rider to be constantly pedaling while the electrical assist was turned on. This could be a safety problem since the forced movement of the legs would have been unnatural and distracting for the rider.

3.1.3. Separate Chain-driven:

The separate chain-driven design was where there would be a motor on a separate chain than the pedals to drive the rear wheel. The advantages of this were the same as the integrated chain-driven option, but, by modifying the rear hub, the freewheeling problem could be eliminated.

The disadvantage of this system was that there could have been rider or frame clearance conflicts. By adding an extra chain to the bike there could have been issues with the rider getting their clothing caught or that parts of the bike frame may have interfered with the chain. To protect the rider there would have

to be a chain guard similar to a motorcycle chain guard. To deal with the frame interferences mounting brackets would have needed to be designed.

3.2. Trailer:

For the trailer multiple systems within the trailer were chosen to be analyzed for the designs and they were: the brakes, suspension, electrically assisting the rear wheels, and the type of construction.

3.2.1. Brakes:

The first consideration for the trailer was a braking system. This system would consist of adding brakes to the rear wheels on the trailer which would be activated through the bikes braking system. The advantages of this design were that it added stability, safety and control. This method allowed for more stability because, while breaking, the trailer would not be pushing the bike. The additional brakes added safety to the system by allowing the bike to reduce its speed much more quickly. Finally, by being able to slow the vehicle quicker, it would allow the rider to have more control over the system.

The disadvantages of this system were that it added complexity and cost. Since the brake line connections, brake placement brackets and braking interface would have to be designed it would be very complex to add these to the trailer. Also, the cost would increase due to the use of more parts.

3.2.2. Suspension:

The next design consideration for the trailer was the suspension. This consisted of either leaf springs or a shock and spring setup. The advantage of this system was that it would add stability to the trailer and safety to the overall system. By adding suspension to the trailer it would reduce the risk of it toppling when hitting bumps or other obstacles. Also, by preventing the trailer from tipping over it makes it much safer for the rider to haul.

The disadvantages of adding suspension were that it adds complexity and cost to the project. Since suspension design is generally difficult it would have been challenging to design a new system for the trailer. Besides being complex, the additional parts required would increase the cost.

3.2.3. Electrically Assisted Trailer:

Electrically assisting the trailer was another design considered. This consists of adding an electric hub motor or chain-driven option to the trailer. The advantage of this was that it would add more power to the overall system. This would allow for a less powerful motor driving the bicycle which could reduce the frame and rider interference since the size of the motor could be reduced.

The disadvantages of adding electrical assist to the trailer were that it would add complexity and cost. It would be difficult to incorporate the trailer's electrical assist with the bicycle's electrical assist. Also, consideration for when and how the device would activate would need to be done. Again, since more parts would need to be purchased the cost will go up.

3.2.4. Welded vs. Bolted vs. Bamboo Construction:

There were three considerations for the construction of the trailer: welded, bolted or bamboo construction. In any situation they would still have the same features as the others. For the welded construction the advantages would be that it would be very strong. The disadvantages of this were that it would be difficult to disassemble and redesign.

The advantages for the bolted construction were that it could be easily disassembled and it would allow for more parts to be easily added. The disadvantage of this was that it would not have the strength that the welded construction would have.

Finally, the advantage of the bamboo construction was that it was almost completely sustainable. Being able to grow parts for use in the trailer would be a substantial step towards total sustainability which was very important to our sponsor. The disadvantages were that it would be difficult material to work with and it may not have the performance required.

4. DESIGN SELECTED

4.1. Rationale for Design Selection

The solution that was chosen was to use the integrated chain driven design for the electrical assist with brakes and a bolted construction for the trailer. This was determined to be the best solution for many reasons. The design selected includes an electrical assist that has an option for gearing, has customizable orientations, eliminates the freewheeling problem, and has necessary power to climb 4° incline hills at 10mph. The trailer was chosen to have brakes for safety and it is to be of a bolted construction ease of manufacture and maintenance.

These decisions were made with the aid of decision matrices. Using each customer requirement's relative importance, a datum chosen by design members, and an average subjective rating by design members for each component relative to the datum, an overall decision may be made. A positive total indicates component is superior to datum, a zero indicates component in question is equivalent to datum, and a negative value indicates designated component is inferior to datum.

The first major decision that needed to be made was whether the drive train would be more effective as a hub motor configuration or a chain driven one (Table 1).

Drivetrain Decision Matrix				
Customer Requirements	Importance	Hub Motor	Chain Driven	
GENERAL	It must be safe	12	4.00	D A T U M
	It must be strong and durable	12	1.33	
	It must use as many donated and used parts as possible	5	0.00	
	Users manual and laminated information card	10	1.00	
	It must be within the budget	10	-2.00	
ELECTRIC ASSIST REOS.	It must attach to and power rear wheel	10	0.00	
	It must have a battery mounted on the rack or top tube, or trailer	10	0.00	
	The battery must be rechargeable by a standard outlet	15	0.00	
	The throttle must be mounted on the handlebars in an easy to use position	15	0.00	
	It must be transferable between mountain bikes of similar size for maintenance issues	10	0.00	
	It must provide appropriate power for hauling the designated load	15	-5.00	
	Must drive 15 mph on level ground, 10mph over bridge	15	-1.67	
Electric power must come on smoothly (no unexpected burst of power) and shut off instantly	18	0.00		
Total:			-110.00	

Table 1: Drivetrain Decision Matrix

Observing the high magnitude result indicates one option is far superior to the other, while the negative indicates that the hub motor is a much worse choice than a chain driven system. The major contributing factors to this high negative value are performance related. A hub motor would have inadequate power to meet the speed and adequate power customer requirements.

Next, the type of bicycle disc brake systems needed to be chosen (Table 2).

Bike Disc Brakes Decision Matrix				
	Customer Requirements	Importance	Mechanical	Hydraulic
GENERAL	It must be safe	12	-2.00	D A T U M
	It must be strong and durable	12	-1.67	
	It must use as many donated and used parts as possible	5	0.00	
	Users manual and laminated information card	10	0.67	
	It must be within the budget	10	0.33	
BIKE REQS.	It must be a used mountain bike	5	0.00	
	It must have disc brakes	10	0.00	
	Must have high traction tires standard	12	0.00	
	Must be easy to maintain and change parts	10	0.00	
Total:			-34.00	

Table 2: Bike Disc Brakes Decision Matrix

This decision matrix indicates hydraulic disc brakes are the better choice. Although hydraulic disc brakes are preferable to mechanical disc brakes, interfacing issues arise when attempting to link bicycle and trailer brake controls. In order to interface the controls effectively, the linked brake handle needs to have two cables that actuate the rear bicycle brake and trailer brakes. The solution chosen was to make use of one hydraulic disc brake on the front bicycle tire while having a dual mechanical brake system for the rear bicycle brake and trailer brakes.

For the trailer to be constructed properly and efficiently a part interfacing system has to be chosen. The two choices are between a welded or bolted construction method (Table 3).

Trailer Construction Decision Matrix				
	Customer Requirements	Importance	Welded	Bolted
GENERAL	It must be safe	12	-2.50	D A T U M
	It must be strong and durable	12	4.00	
	It must use as many donated and used parts as possible	5	0.00	
	Users manual and laminated information card	10	0.00	
	It must be within the budget	10	-3.00	
TRAILER REQS.	It must be able to haul 250 lbs of agricultural items	15	0.00	
	It must be designed around Rubbermaid tubs (18, 14, and 10 gallons)	5	0.00	
	It must be road-legal	12	0.00	
	It must have a stable load	12	0.00	
	It must have a stable hitch	12	0.00	
Total:			-12.00	

Table 3: Trailer Construction Decision Matrix

The trailer construction decision matrix indicates that a bolted design will more adequately achieve our customer and engineering requirements

In addition to trailer construction method, a suspension method must be chosen (Table 4).

Trailer Suspension Decision Matrix					
	Customer Requirements	Importance	No Suspension	Spring-Damper	Leaf Spring
GENERAL	It must be safe	12.00	D A T U M	2.00	2.67
	It must be strong and durable	12		-2.00	-2.00
	It must use as many donated and used parts as possible	5		0.00	0.00
	Users manual and laminated information card	10		0.00	0.00
	It must be within the budget	10		-6.50	-6.00
TRAILER REQS	It must be able to haul 250 lbs of agricultural items	15		0.67	0.67
	It must be designed around Rubbermaid tubs (18, 14, and 10 gallons)	5		0.00	0.00
	It must be road-legal	12		0.00	0.00
	It must have a stable load	12		3.50	3.50
	It must have a stable hitch	12		0.00	0.00
		Total:		-13.00	0.00

Table 4: Trailer Suspension Decision Matrix

According to our criteria, a suspension system that only includes tires is as effective, or more effective than more complex systems that may provide better ride characteristics.

Lastly, the type of trailer brakes must be addressed (Table 5).

Trailer Brakes Decision Matrix						
	Customer Requirements	Importance	No Brakes	Drum	Disc	Rim Brakes
GENERAL	It must be safe	12	-5.00	-2.67	D A T U M	-1.67
	It must be strong and durable	12	1.67	-0.67		-0.33
	It must use as many donated and used parts as possible	5	0.00	0.33		0.67
	Users manual and laminated information card	10	0.00	0.00		0.00
	It must be within the budget	10	5.00	3.00		3.33
TRAILER REQS	It must be able to haul 250 lbs of agricultural items	15	-1.00	0.33		-1.00
	It must be designed around Rubbermaid tubs (18, 14, and 10 gallons)	5	0.00	0.00		0.00
	It must be road-legal	12	0.00	0.00		0.00
	It must have a stable load	12	-1.67	-1.00		-0.33
	It must have a stable hitch	12	0.00	0.00		0.00
		Total:	-25.00	-15.33		-6.33

Table 5: Trailer Brakes Decision Matrix

This analysis suggests that a disc brake system is the optimum solution. Although it would provide the best results based on these importance values outlined by our customer, we are choosing rim brakes in order to cut costs. The difference in performance between the datum of disc brakes and rim brakes is only 6.33 points which implies that the rim brakes will be almost as effective in meeting our requirements and will not significant negative impact as compared to disc trailer brakes.

The disadvantages of this design are that it will be complex to build (i.e. many bolts and connectors), it may have rider or frame clearance problems, and it may be expensive compared to less effective alternative designs. Overall the advantages far outweigh than these few disadvantages and therefore this is why we are choosing to proceed with this concept.

4.2. Design Description

4.2 Design Description

The design selected for this project is broken into three sub sections: the bicycle, electrical assist, and trailer.

4.2.1. Bicycle:

The bicycle obtained for this project is a used Haro mountain bike. The two subsystems of the bicycle are the brakes and hitch system.

4.2.1.1. Brakes:

The bicycle will utilize hydraulic disc brakes in the front and mechanical disc brakes in the rear. The reason for this setup is that the hydraulic brakes give more stopping power to the bike while the mechanical brakes allow for a dual cable brake lever (Figure 8). The dual cable brake lever is important because it will be used to actuate the trailer brakes for even more stopping power.



<http://www.amazon.com/gp/product/B000AO7H16?&tag=shopwiki-us-20&linkCode=as2&camp=1789&creative=9325>

Figure 8: Dual cable brake lever

4.2.1.2. Hitch System:

The hitch system consists of two main parts: the hitch mount and the hitch ball. The mount will be a heavy duty hitch from Tony's Trailers. It was chosen because it triangulates the load between the rear dropouts and the seat post giving extra strength compared to other mounts. The ball will be a 1in stainless steel trailer hitch ball rated for 2000 lbs. This was chosen since it has three degrees of freedom, high load rating, and a low price.

4.2.2. Electrical Assist:

The electrical assist kit being purchased is a 1200W kit from Cyclone USA (Figure 9). This kit consists of a 1200W motor, chain wheel system, throttle and controller. Also, 12V 12Ah batteries will be purchased to power the device.



<http://www.cyclone-tw.com/0bike.htm>

Figure 9: Electrical Assist Kit

4.2.2.1. Motor:

The motor has an internal controller, planetary gearbox and is specified to operate at 1200W. 1200W was chosen due to the calculations in appendix A.

4.2.2.2. Chain-wheel System:

The chain-wheel system uses a three piece chain-wheel free-wheel crank set, this allows the use of the front derailleur and freewheeling. There are two chains for the system, one attaches to the motor and freewheeling chainring, the second chain attaches to the rear cassette and front non-freewheeling chain rings.

4.2.2.3. Throttle:

The throttle is attached to the front right handle grip and is thumb actuated.

4.2.2.4. Controller:

The controller controls the flow of current to the motor based on the throttle's position.

4.2.2.5. Batteries:

There are 4 lead acid batteries each being 12V 12Ah. These were chosen since, in the worst case scenario, they will have enough charge to complete the trip. See the calculations in appendix A.

4.2.3. Trailer:

The trailer is a two wheel design constructed from 1 in. square aluminum tubing and steel connectors (Figure 10). The two subsystems of the trailer are the brakes and the materials used.

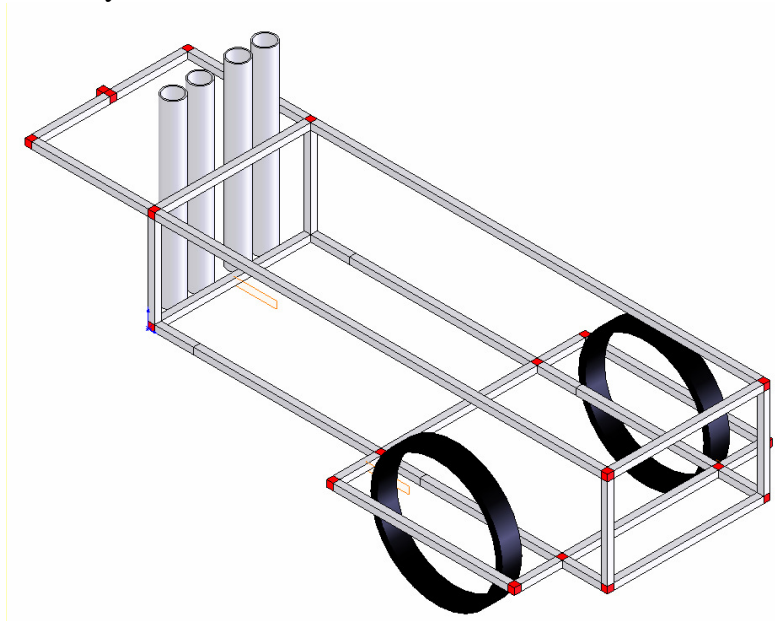

Figure 10: Evaluation One Trailer Design

4.2.3.1. Brakes:

The braking system to be used on the trailer will be rim brakes on 20in bicycle wheels. They will be actuated by the rear bicycle dual cable brake lever as stated earlier.

4.2.3.2. Materials:

The materials being used for the trailer frame are 1in x 1in square aluminum tubing and plastic covered hollow steel connectors. The bed of the trailer will be 1/16in aluminum sheet metal and the wheels will be 20in bicycle wheels.

5. IMPLEMENTATION

Implementation of our design was accomplished by the fabrication of a prototype. Fabrication of a prototype rather than the creation of a proof-of-concept was chosen because the OSU Organic Growers Club wanted a functioning model. Most of the fabrication associated with this project was for the trailer. The trailer was made primarily of 1" x 1" square aluminum tubing and special EZ Tube connectors from International Designs (see Bill of Materials). These connectors allowed for a similar build process as the one used in the PVC prototype build and gave the trailer modular functionality. Allowing for modular construction increased the usefulness of the trailer. This was important because the OSU Organic Growers Club can easily modify the trailer to fit their future needs.



<http://www.eztube.com/connectors/connectors.html>

Figure 11: EZ Tube connectors

The EZ Tube connectors (Figure 11) featured a steel core with a plastic coating. They are able to support 250 lbs in shear. Therefore they are strong enough for our application because in the design chose they experience a maximum of 72.5 lbs in shear allowing a factor of safety of four under normal loading conditions. The first major issue in the implementation process was that of backordered parts. EZ Tube did not have all of the correct connectors in stock so delays in construction occurred. These back ordered parts could have caused a large problem for evaluation one, but EZ Tube instead sent carbon fiber connectors, free of charge, to substitute for the steel core connectors until they could be shipped

Although the EZ Tube connection system was designed to be a boltless construction process, bolts were used in the legs of each connector to reduce the likelihood that members of the trailer could vibrate loose. Originally the trailer was designed to have two bolts in each connector leg, but when the trailer build took place it was realized that two bolts would have removed too much of the connector material created large stress concentrations. Thus a single bolt per leg was used in actual implementation.

As seen in Figure 11, a redesign of the trailer's tongue-hitch interface was performed during the initial build process in order to reduce the complexity of the design and manufacturing process. An off-the-shelf hitch and

tongue from Bike at Work was selected and thus reduced the amount of joints required by the trailer. This resulted in a more robust interface than the original design as well as one that had been proven by the use in other trailer applications.

The trailer tongue redesign redistributed the space that could be used for battery storage and thus the batteries were placed in the farthest forward position on the trailer for evaluation one. This immediately showed that there was an excessive tongue loading due to the loading imbalance caused by the batteries. The solution for this excessive tongue load was to relocate the trailer wheels to the center of the load bearing surface of the trailer as well as relocate the batteries to the centerline of the new wheel position.

Another issue found in the evaluation one trailer build was that of excessive deflection of the wheel wells and trailer structural members. Wheel well diagonal members, frame uprights, and frame cross members were added to provide structural rigidity under loading conditions.

One major user mistake occurred during the trailer re-build after evaluation one. When disassembling the interference fits of the EZ Tube connectors from the aluminum tubing one of the cross connectors failed. A replacement part was going to be purchased, but after explaining that one of their products had failed to the EZ Tube representative a replacement part was rush delivered at their expense. This was most likely due to a quality control or customer guarantee that EZ Tube uses.

The implementation for the bicycle and electric assist was originally thought to be assembling existing products. This was accurate for the majority of the components, but issues arose in ergonomic design of the throttle and the motor mounting bracket. The throttle that came with the electric assist system interfered with the trigger shifter of the bicycle's rear de-railer which required the replacement of the trigger shifter with a grip shifter which allowed for the full throttle motion.

Next, the motor mounting bracket was meant for a bicycle frame with a small, constant diameter tube, but the bicycle frame used had a tapered ellipse shape that the bracket would not fit. A custom motor mount was designed such that the motor could be securely attached to the bicycle frame. A local machine shop was to be used in the manufacturing of this custom mount, but their time estimate for completion of the motor mount was not consistent with their actual practice. Therefore another shop, White's Electronics a company a group member interned with, was used to manufacture the motor mount. This alternative was advantageous due to the group member connection and the service was provided for free.

6. TESTING

7. PROJECT SUMMARY

On the whole, senior project provided much insight into design as a process rather than simply an analysis exercise. The project as a whole taught the group about team dynamics, high level project management issues, and the importance of time management.

As a team, our group realized that as deadlines approached, all three members could not work simultaneously on the same task. When all three members did this, there was too much input from each member and it took much longer to reach a consensus on any decision, but when the group multi-tasked decisions were made and then reviewed. In particular, this strategy came into play when writing the various reports. Separating the workload by sections and then using a peer editing process allowed for the timely drafting of the reports while maintaining consistency through those papers.

High level project management issues arose in a variety of instances. The first instance pertained to the clarity of the project definition during the first term of the project. Multiple sources of input pertaining to the scope of the project led to confusion of who the project was for and what the goal of the project was. After speaking with our faculty advisor about this, it was suggested that he would help clarify these points of confusion with the project sponsor and course instructor such that lines of communication would stay open. This was a valuable lesson for our group as it showed how a more experienced engineer than us would handle a situation pertaining to blocked lines of communication as this is likely to happen often in our future careers.

After clarifying the project definition and goal, it was realized that the original start-up grant was intended for a project with a different scope. This meant that additional funds would be required to meet the goals outlined by our project sponsor and therefore more funding was requested from the Student Sustainability Initiative during week seven of the first term. As with any bureaucratic process, a relatively large amount of time was needed to complete the request for additional grant funding. A decision was not made to approve the extra funding until week two of ME 419 delaying the initial build process.

Next, it was realized that interactions with the project sponsor and interactions with a faculty advisor had to be conducted in different fashions. Due to the fact that the project sponsor did not have the technical knowledge, the group had to effectively interpret qualitative needs into a physical system. Although this is the driving idea behind written customer requirements, there were more expectations that the sponsor may have had that were not fully conveyed. On the other hand, consultation with our faculty advisor allowed for a quantitative path of communication. This difference in communication dynamics allowed us to more effectively prepare ourselves for meetings with people with various levels of technical knowledge.

Lastly, time management and planning was key to the success of the project. Although we attempted to complete tasks early in theory, this was not always possible in practice. It was learned that even though tasks were not always completed early, the effort to complete tasks early allowed the group to complete tasks in a quality fashion and by a deadline.

The final Bill of Materials was as shown below:

Number	Description	QTY	Total Cost	Location
G-001	Bolts	100	Donated	Hoy's Truevalue Hardware
G-002	Nylon Nuts	100	Donated	Hoy's Truevalue Hardware
G-003	Wire	20ft	Donated	Hoy's Truevalue Hardware
G-004	Reflective Tape	10ft	Donated	OSU Bike Co-op
G-005	Safety Flag	1	Donated	Arbor Creek Farms

G-007	Safety Banner	1	Donated	Arbor Creek Farms
G-008	Zip Tie Set	1	Donated	Arbor Creek Farms
G-009	Velcro Strap Set	1	Donated	Arbor Creek Farms
B-001	Used Mountain Bike	1	Donated	OSU Bike Co-op
B-002	Hydraulic Brake, computer, light	3	\$ 86.50	Full Cycles
B-003	Rear Cable Brake	1	\$ 69.95	Corvallis Cyclery
B-004	Dual Brake Level Pull	1	\$ 15.48	Amazon
E-001	Electrical Assist Kit	1	\$ 815.95	Cyclone USA
E-002	Batteries	4	\$ 202.50	Electric Rider
E-003	Charger	1	Donated	Arbor Creek Farms
T-001	1inx1in Square Aluminum Tubing (21ft sections)	7	\$ 160.00	Middleton
T-002	Connectors (Ts, Ls, Crow, 4-way, 3-way)	19	\$ 189.53	International Design
T-003	Galvanized L Brackets	4	Donated	Arbor Creek Farms
T-008	20" Bicycle Wheels/Tires/Tubes	2	Donated	Arbor Creek Farms
T-010	Wheel Mount Bearings	2	\$ 43.62	McMaster
T-011	Hitch	1	\$ 134.24	Bikes at Word
T-012	Bearing	2	\$ 19.21	McMaster
T-013	Wood Flooring	3	Donated	Arbor Creek Farms
T-014	Battery Box	1	Donated	Arbor Creek Farms
T-015	Battery Straps	1	Donated	Arbor Creek Farms
T-016	Tie Down Set	1	Donated	Arbor Creek Farms
T-017	Shims	164	\$ 68.00	Middleton
			Total:	\$ 1,804.98

The final budget agrees with this final Bill of Materials.

Transaction Details (excluding Budget JVs) for:

2/24/2010

Index: EMM201

Period: Get!3Month (Current Fiscal Year)

Activ	Acct	Trans Date	Doc Code	Doc Type	Rule Code	Item#	Seq#	Vendor Inv#	Transaction Description	Trans Amt Dr	Trans Amt Cr
ESNR	20111	12-Jan-10	Z0097916	INV	IPNI		1		AMAZON MKTPLACE PMTS	15.48	
ESNR	20111	12-Jan-10	Z0098112	INV	IPNI		1		CORVALLIS CYCLERY CO	49.95	
ESNR	20111	15-Jan-10	Z0098432	INV	IPNI		1		INTERNATIONAL DESIGNS	11.53	
ESNR	20111	15-Jan-10	Z0098434	INV	IPNI		1		INTERNATIONAL DESIGNS	178.00	
ESNR	20111	25-Jan-10	Z0098979	INV	IPNI		1		BIKES AT WORK INC.	134.24	
ESNR	20111	26-Jan-10	Z0099000	INV	IPNI		1		TXELECTRIC3252276903	202.50	
ESNR	20111	29-Jan-10	I2029222	INV	INNI		1	REIM REQ 1/10	Baker, Jack Hamilton.	86.50	
ESNR	20111	29-Jan-10	Z0099429	INV	IPNI		1		ELECTRICMOU	815.95	
ESNR	20111	4-Feb-10	I2030921	INV	INNI		1	REIM REQ 2/10	Baker, Jack Hamilton.	20.00	
ESNR	20111	8-Feb-10	I2032037	INV	INNI		1	71359	Middleton Heating & Sheet Metal Inc	160.00	
ESNR	20111	8-Feb-10	I2032038	INV	INNI		1	71525	Middleton Heating & Sheet Metal Inc	68.00	
ESNR	20111	17-Feb-1	I2035378	INV	INNI		1	47623415	McMaster-Carr Supply Company	19.21	
ESNR	20111	22-Feb-1	I2037088	INV	INNI		1	47841110	McMaster-Carr Supply Company	43.62	
Acct subtotal:										\$1,804.98	\$0.00
ESNR	79392	22-Jan-10	J0447102	JV	3JV1		2		Support of ME Elect Bike SR Project		1,000.00
ESNR	79392	28-Jan-10	J0447461	JV	3JV1		2		OrganicGrowersElectricBikeTrailerPr		810.00
Acct subtotal:										\$0.00	\$1,810.00
Activity subtotal:										\$1,804.98	\$1,810.00
Grand Total:										\$1,804.98	\$1,810.00

BIBLIOGRAPHY

- Avid. (2009, Oct. 20). *Hydraulic Disc Brakes*. [Online]. Available: <http://www.sram.com/en/avid/hydraulicdiscbrakes/code.php#>
- Bikes at Work. (2009, Oct. 20). *Bike Trailer Features*. [Online]. Available: <http://www.bikesatwork.com/bike-trailers/features.html>
- BionX. (2009, Oct. 20). *Technology*. [Online]. Available: <http://www.bionx.ca/products/technology.php>
- Blanco, S. (2008, April 8). Retrieved October 20, 2009, from Green Autoblog: <http://green.autoblog.com/2008/04/08/miles-zx40st-work-truck-introduced-in-sacramento-today/>
- Carry Freedom. (2009, Oct. 20). *The Bamboo Bicycle Trailer*. [Online]. Available: <http://www.carryfreedom.com/bamboo.html>
- Electric Rider. (2009, Oct. 20). *Electric Bike Conversion Kits*. [Online]. Available: <http://www.electricrider.com/crystalite/index.htm>
- Hayes. (2009, Oct. 20). *Hydraulic Disc Brakes*. [Online]. Available: http://www.hayesdiscbrake.com/product_hyd_strokerAce.shtml
- Klein, Richard E., "The Bicycle Project Approach – A Vehicle to Relevancy and Motivation," *1991 Frontiers in Education Conference*, 49, 1991. [Online]. Available: <http://ieeexplore.ieee.org/stamp/stamp.jsp?arnumber=00187432>. [3 Nov 09].
- Tony's Trailers. (2009, Oct. 20). *Cargo Bicycle Trailers*. [Online]. Available: <http://www.tonystrailers.com/cargo/>
- <http://www.amazon.com/gp/product/B000AO7H16?&tag=shopwiki-us-20&linkCode=as2&camp=1789&creative=9325>
- <http://www.cyclone-tw.com/0bike.htm>
- <http://www.eztube.com/connectors/connectors.html>

8. APPENDIX A: ENGINEERING CALCULATIONS

Finding the Power and Torque needed to climb a hill:

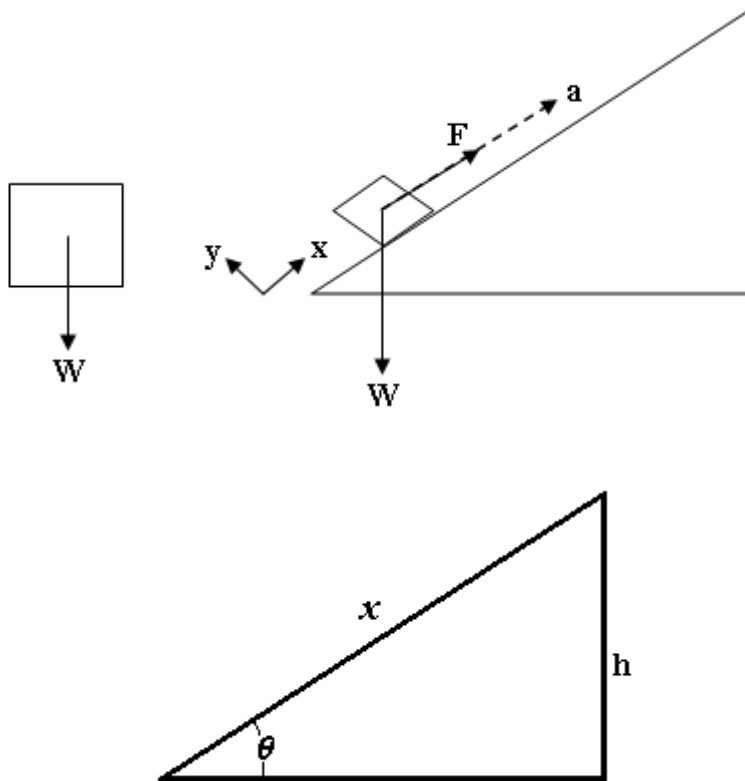

Conservation of Energy

$$\sin \theta = \frac{h}{x}$$

$$W + PE_i + KE_i = PE_f + KE_f$$

$$W = mgh_f = \frac{1}{2}mv_f^2$$

$$W = mgx \sin \theta + \frac{1}{2}mv_f^2$$

$$P_{add} = \frac{W_{add}}{t} = \frac{mgx \sin \theta + \frac{1}{2}mv_f^2}{2}$$

Assume the bike reaches v_f at the top of the hill.

To find t:

$$x = x_o + v_o t + \frac{1}{2}at^2$$

$$v = v_o + at$$

$$v^2 = v_0^2 + 2a\Delta x$$

$$t = \frac{v_f}{a}$$

$$a = \frac{v_f^2}{2\Delta x}$$

$$t = \frac{\frac{v_f}{v_f^2}}{\frac{v_f^2}{2\Delta x}} = \frac{2\Delta x}{v_f}$$

$$P_{add} = \frac{mgx \sin \theta + \frac{1}{2}mv_f^2}{t}$$

$$P_{add} = \frac{mgx \sin \theta + \frac{1}{2}mv_f^2}{\frac{2x}{v_f}}$$

$$P_{add} = \left(mgx \sin \theta + \frac{1}{2}mv_f^2 \right) \frac{v_f}{2x}$$

$$P_{add} = \frac{mgv_f \sin \theta}{2} + \frac{mv_f^3}{4x}$$

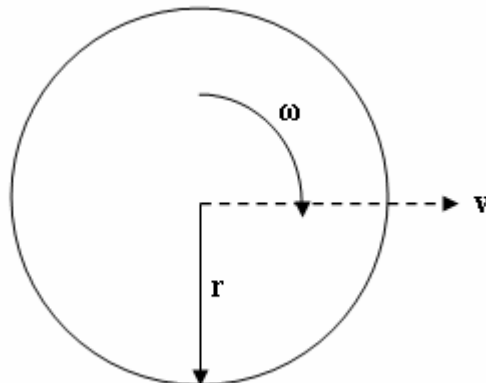

$$P = \tau\omega$$

$$\tau = \frac{P}{\omega} = \frac{P}{\frac{v}{r}} = \frac{Pr}{v}$$

$$\tau = \frac{P}{\omega_{avg}} = \frac{P}{\frac{2v_f}{r}} = \frac{Pr}{2v_f}$$

Finding the Power to climb a hill, but meeting the maximum velocity before the top of the hill:

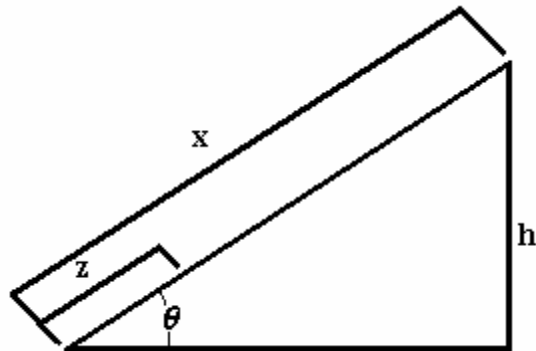

z = distance to reach final velocity
 x = distance on slope

$$P_{add} = \frac{mgx\sin\theta + \frac{1}{2}mv_f^2}{t}$$

To find t :

$$v^2 = v_0^2 + 2a\Delta x$$

$$v^2 = 2a\Delta x$$

$$a = \frac{v_f^2}{2\Delta z} = \frac{v_f^2}{2z}$$

$$v = v_o + at = at$$

$$x = x_o + v_o t + \frac{at^2}{2}$$

$$t_1 = \frac{v_f}{a} = \frac{v_f}{\frac{v_f^2}{2z}} = \frac{2z}{v_f}$$

To find time for steady state:

$$x = z + v_f t_2 + \frac{at_2^2}{2} = z + v_f t_2$$

$$t_2 = \frac{x - z}{v_f}$$

$$t_{TOT} = t_1 + t_2 = \frac{2z}{v_f} + \frac{x - z}{v_f} = \frac{x + z}{v_f}$$

$$P_{add} = \frac{mgx \sin \theta}{\frac{x + z}{v_f}} + \frac{mv_f^2}{2} = (mgx \sin \theta + mv_f^2) \left(\frac{v_f}{x + z} \right)$$

$$P_{add} = \frac{mgx v_f \sin \theta}{x + z} + \frac{mv_f^3}{2(x + z)}$$

$$W_{add} + PE_i + KE_i = PE_f + KE_f$$

$$W_{add} = \frac{mv_f^2}{2}$$

$$P_{add} = \frac{W_{add}}{t} = \frac{mv_f^2}{2t}$$

$$P_{add} = \frac{mv_f^2}{\frac{2x}{v_f}} = \frac{mv_f^2}{2} \left(\frac{v_f}{2x} \right) = \frac{mv_f^3}{4x}$$

$$W_{add} = mgh_f - mgh_i = mgh$$

$$P_{add} = \frac{mgh}{t}$$

$$P_{add} = mgv\sin\theta$$

MATLAB outputs for calculating Motor Power Output requirements

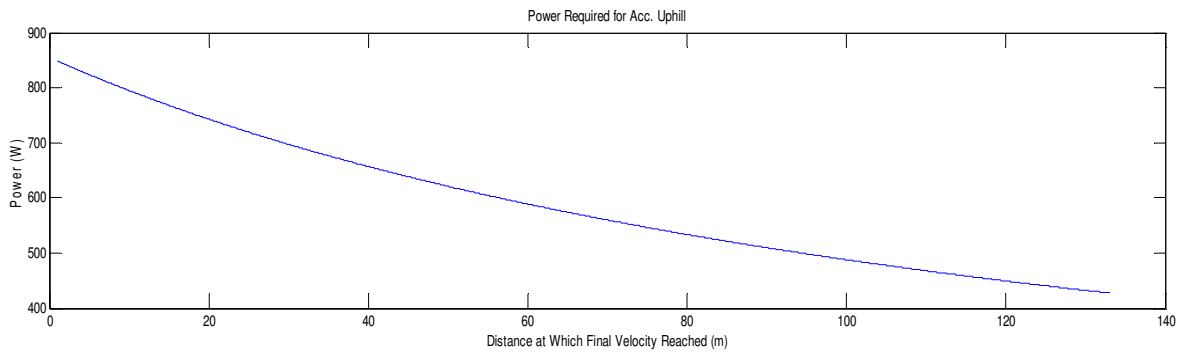
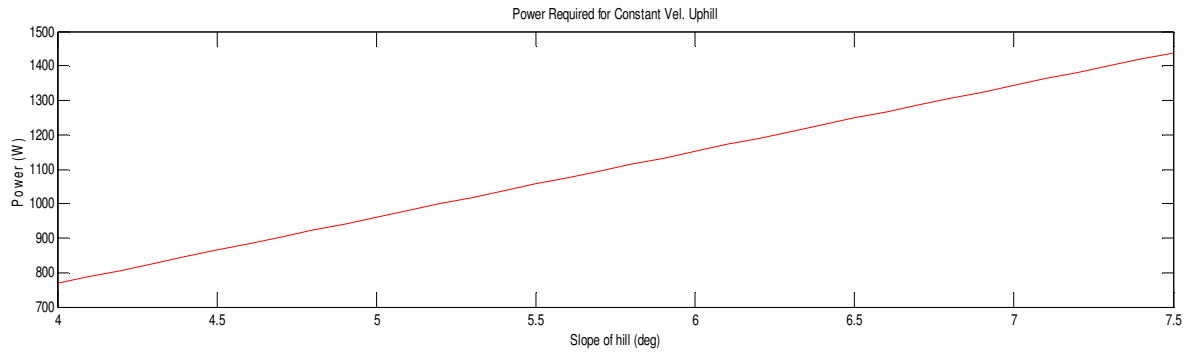
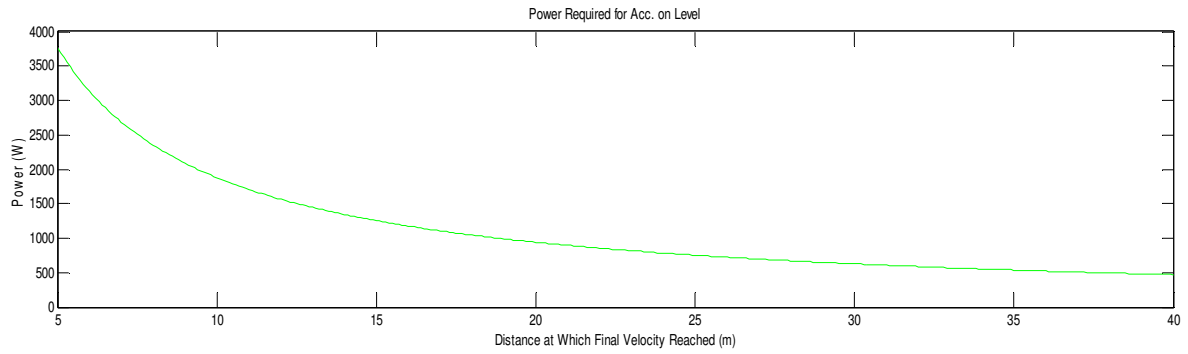

MATLAB Code:

```
clear
clc

%Power calcs for acceleration on the level

m=250;      %mass of entire system in kg
vf=6.7;     %final velocity in m/s
x=5:.1:40;  %distance at which final velocity is achieved in m

for i=1:length(x)
P1(i)=m*vf^3/(4*x(i));
end

subplot(3,1,1)
plot(x,P1,'b')
grid on
title('Power Required for Acc. on Level')
```

```

xlabel('Distance at Which Final Velocity Reached (m)')
ylabel('Power (W)')

%Power calcs for constant velocity up a hill

m=250;           %mass of entire system in kg
vf=4.5;         %final velocity in m/s
g=9.8;
theta=4:.1:7.5; %slope of incline in degrees

for j=1:length(theta)
P2(j)=m*g*vf*sind(theta(j));
end

subplot(3,1,2)
plot(theta,P2,'r')
grid on
title('Power Required for Constant Vel. Uphill')
xlabel('Slope of hill (deg)')
ylabel('Power (W)')

%Power calcs for accelerating up a hill from a stop

x=133;          %distance to peak of hill in m
z=1:.1:x;      %distance at which final velocity is achieved in m
theta=4;

for k=1:length(z)
P3(k)=(m*g*vf*x*sind(theta))/(x+z(k))+m*vf^3/(2*(x+z(k)));
end

subplot(3,1,3)
plot(z,P3,'b')
grid on
title('Power Required for Acc. Uphill')
xlabel('Distance at Which Final Velocity Reached (m)')
ylabel('Power (W)')

```

Battery Calculations:

Distance, Location and Assumed Power Consumption		
Distance	Location	Power
0.0261mi	9 th Street Merging	2000W
.3mi	Harrison Bridge	700W
2.6mi	Total Distance	2000W

$$x = x_0 + v_0 t + \frac{1}{2} a t^2$$

$$v = v_0 + a t$$

$$v^2 = v_0^2 + 2a\Delta x$$

$$t = \frac{v_f}{a}$$

$$a = \frac{v_f^2}{2\Delta x}$$

$$t = \frac{\frac{v_f}{v_f^2}}{\frac{v_f^2}{2\Delta x}} = \frac{2\Delta x}{v_f}$$

$$(\text{Amp Hours}) \times \left(\frac{3600s}{1h}\right) = \text{Coulombs}$$

Time spend and charge used at each location		
Location	Time	Charge used
9 th Street Merging	6.264s	125.28C
Harrison Bridge	108s	2160C
Remaining Distance	818.604s	16,372.08C
Return to the Farm	936s	18,720.0C
	Total	37,377.20C

Comparison of Charge Used and the Total Charge in the Batteries	
Charge in Batteries	-37,377.20C
Charge Used	43,200.00C
Total	5,822.64C

9. APPENDIX B: BILL OF MATERIALS

General BOM

Number	Component	QTY	Price	Purchasing Info	Lead Time
G-001	Bolts	150	N/A	Donated by Hoy's Truevalue Hardware	N/A
G-002	Nylon Nuts	150	N/A	Donated by Hoy's Truevalue Hardware	N/A
G-003	Wire	20ft	N/A	Donated by Hoy's Truevalue Hardware	N/A
G-004	Safety Reflector	8	N/A	Donated by OSU SSI	N/A

Bike BOM

Number	Component	QTY	Price	Purchasing Info	Lead Time
B-001	Used Bike	1	N/A	Donated by OSU SSI	N/A
B-002	Rear Cable Disk Brake Kit	1	\$ 35.00	JensenUSA.com	3-5 days
B-003	Front Hydraulic Disk Brake Kit	1	\$ 50.00	JensenUSA.com	3-5 days
B-004	Rear Rack	1	\$ 150.00	Ton'ys Trailers	12 days
B-005	Hitch Ball	1	\$ 19.99	AutoZone	1 day
B-006	Dual Brake Lever	1	\$ 9.99	Amazon.com	3 days
G-001	Bolts (Mounting of Electrical Assist)	150	N/A	Donated by Hoy's Truevalue Hardware	N/A
G-002	Nylon Nuts	150	N/A	Donated by Hoy's Truevalue Hardware	N/A

Electrical Assist BOM

Number	Component	QTY	Price	Purchasing Info	Lead Time
E-001	Electrical Assist Kit	1	\$ 390.00	Cyclone USA	3 days
E-001-1	1200W DC Motor	1	N/A	Cyclone USA	3 days
E-001-2	Motor Mounting Brackets	1	N/A	Cyclone USA	3 days
E-001-3	Spacer Bolts	1	N/A	Cyclone USA	3 days
E-001-4	44 Tooth Freewheeling Chainwheel	1	N/A	Cyclone USA	3 days
E-001-5	Bottom Bracket Spindle	1	N/A	Cyclone USA	3 days
E-001-6	Left Crank Arm	1	N/A	Cyclone USA	3 days
E-001-7	Right Crank Arm	1	N/A	Cyclone USA	3 days
E-001-8	Twist Grip Throttle	1	N/A	Cyclone USA	3 days
E-001-9	Handlebar Grips	2	N/A	Cyclone USA	3 days
E-001-10	Brake Handles w/ Battery Cutoff	2	N/A	Cyclone USA	3 days
E-001-11	Battery Connection Harness	1	N/A	Cyclone USA	3 days
E-002	Batteries 12V 12AH EB12-12T2	4	\$ 119.96	Battery Mart	3 days
G-003	Wire	20ft	N/A	Donated by Hoy's Truevalue Hardware	N/A

Trailer BOM

Number	Component	QTY	Price	Purchasing Info	Lead Time
T-001	1"x1" Square Aluminum Tubing 8ft	7	N/A	Donated by Hoy's Truevalue Hardware	N/A
T-002	T Joints	1	\$ 8.75	International Designs (MFG of easy tube)	1 day
T-003	L Joints	6	\$ 51.00	International Designs (MFG of easy tube)	1 day
T-004	Crow Joints	4	\$ 36.00	International Designs (MFG of easy tube)	1 day
T-005	4 Way Joints	2	\$ 18.50	International Designs (MFG of easy tube)	1 day
T-006	3 Way Joints	6	\$ 54.00	International Designs (MFG of easy tube)	1 day
T-007	Galvanized L Brackets 6ft	4	N/A	Donated by Hoy's Truevalue Hardware	N/A
T-008	20" Bicycle Wheels	2	N/A	Donated by OSU SSI	N/A
T-009	Cantilevel Bicycle Brakes	2	N/A	Donated by OSU SSI	N/A
T-010	Aluminum Sheet Metal 8'x10'	1	N/A	Donated by Hoy's Truevalue Hardware	N/A
G-001	Bolts	150	N/A	Donated by Hoy's Truevalue Hardware	N/A
G-002	Nylon Nuts	150	N/A	Donated by Hoy's Truevalue Hardware	N/A

Complete BOM

Number	Component	QTY	Price	Purchasing Info	Lead Time
G-001	Bolts	150	N/A	Donated by Hoy's Truevalue Hardware	N/A
G-002	Nylon Nuts	150	N/A	Donated by Hoy's Truevalue Hardware	N/A
G-003	Wire	20ft	N/A	Donated by Hoy's Truevalue Hardware	N/A
G-004	Safety Reflector	8	N/A	Donated by OSU SSI	N/A
B-001	Used Bike	1	N/A	Donated by OSU SSI	N/A
B-002	Rear Cable Disk Brake Kit	1	\$ 35.00	JensenUSA.com	3-5 days
B-003	Front Hydraulic Disk Brake Kit	1	\$ 50.00	JensenUSA.com	3-5 days
B-004	Rear Rack	1	\$ 150.00	Ton'ys Trailers	12 days
B-005	Hitch Ball	1	\$ 19.99	AutoZone	1 day
B-006	Dual Brake Lever	1	\$ 9.99	Amazon.com	3 days
E-001	Electrical Assist Kit	1	\$ 390.00	Cyclone USA	3 days
E-001-1	1200W DC Motor	1	N/A	Cyclone USA	3 days
E-001-2	Motor Mounting Brackets	1	N/A	Cyclone USA	3 days
E-001-3	Spacer Bolts	1	N/A	Cyclone USA	3 days
E-001-4	44 Tooth Freewheeling Chainwheel	1	N/A	Cyclone USA	3 days
E-001-5	Bottom Bracket Spindle	1	N/A	Cyclone USA	3 days
E-001-6	Left Crank Arm	1	N/A	Cyclone USA	3 days
E-001-7	Right Crank Arm	1	N/A	Cyclone USA	3 days
E-001-8	Twist Grip Throttle	1	N/A	Cyclone USA	3 days
E-001-9	Handlebar Grips	2	N/A	Cyclone USA	3 days
E-001-10	Brake Handles w/ Battery Cutoff	2	N/A	Cyclone USA	3 days
E-001-11	Battery Connection Harness	1	N/A	Cyclone USA	3 days
E-002	Batteries 12V 12AH EB12-12T2	4	\$ 119.96	Battery Mart	3 days
T-001	1"x1" Square Aluminum Tubing 8ft	7	N/A	Donated by Hoy's Truevalue Hardware	N/A
T-002	T Joints	1	\$ 8.75	International Designs (MFG of easy tube)	1 day
T-003	L Joints	6	\$ 51.00	International Designs (MFG of easy tube)	1 day
T-004	Crow Joints	4	\$ 36.00	International Designs (MFG of easy tube)	1 day
T-005	4 Way Joints	2	\$ 18.50	International Designs (MFG of easy tube)	1 day
T-006	3 Way Joints	6	\$ 54.00	International Designs (MFG of easy tube)	1 day
T-007	Galvanized L Brackets 6ft	4	N/A	Donated by Hoy's Truevalue Hardware	N/A
T-008	20" Bicycle Wheels	2	N/A	Donated by OSU SSI	N/A
T-009	Cantilever Bicycle Brakes	2	N/A	Donated by OSU SSI	N/A
T-010	Aluminum Sheet Metal 8'x10'	1	N/A	Donated by Hoy's Truevalue Hardware	N/A

10. APPENDIX C: PART DRAWINGS

Note: Wheels for example only
Tool holders for example only
Uses EZ Tube connectors

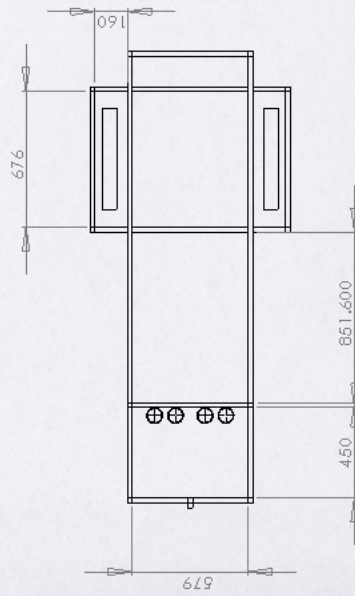
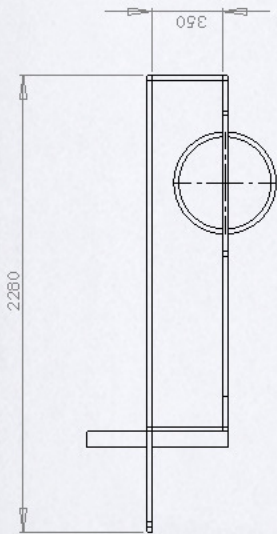
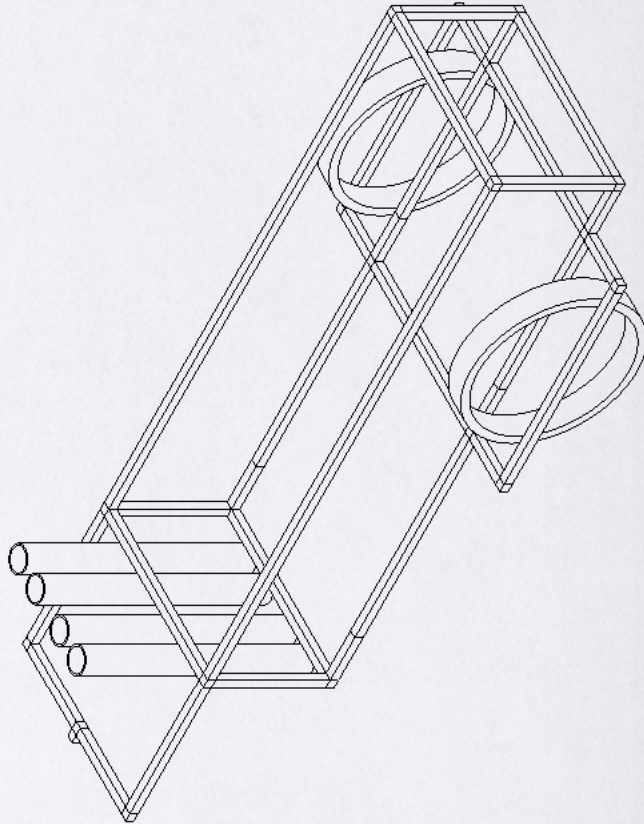
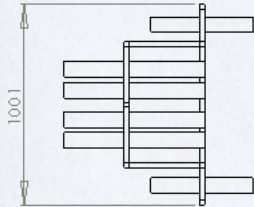

Trailer Model
Drawn By: JHB
not to scale